

REVISIONS					
ZONE	REV	ECN	DESCRIPTION	DATE	APPROVED
	A	1247397	ORIGINAL RELEASE	2017JUL03	T.WU XH.ZHONG
	B	1278122	NOTE 4: 45 WAS 42, 12 WAS 11.	2017DEC06	T.WU XH.ZHONG
	C	1330468	UPDATE AIR INTAKE AND EXHAUST PANEL APPEARANCE	2018DEC10	T.WU P.JIN

NOTES:

- WEIGHT (APPROXIMATE): RS45I (NO DRYER) – 1841 KG (4059 LBS)  
RS55I (NO DRYER) - 1936 KG (4268 LBS)  
RS75I (NO DRYER) - 1962 KG (4325 LBS)  
RS45I (DRYER) - 1994 KG (4396 LBS)  
RS55I (DRYER) - 2089 KG (4605 LBS)  
RS75I (DRYER) - 2115 KG (4663 LBS)
- COOLING AIR FLOW: R45I, R55I: 6,500 M<sup>3</sup>/HOUR (3820 CFM)  
R75I: 10,540 M<sup>3</sup>/HOUR (6200 CFM)
- PIPE CONDENSATE DRAIN LINES SEPARATELY TO AN OPEN DRAIN DUE TO DIFFERENCES IN DRAIN PRESSURES. READ OPERATIONS MANUAL AND CHECK LOCAL REGULATIONS.
- LUBRICANT FILL QUANTITY: 45 LITRES (12 US GALLONS)
- RECOMMENDED CLEARANCE ON THREE SIDES 915 MM (36 INCHES) SIDE WITH ELECTRICAL BOX 1067 MM (42 INCHES) OR MINIMUM AS REQUIRED BY LATEST NATIONAL ELECTRICAL CODE OR APPLICABLE LOCAL CODES.
- EXTERNAL PIPING SHOULD NOT EXERT ANY UNRESOLVED MOMENTS OR FORCES ON UNIT. USE PIPE OF EQUAL OR GREATER SIZE AT DISCHARGE LOCATION OF UNIT.
- THERE SHOULD BE NO PLASTIC OR PVC PIPING ATTACHED TO THIS UNIT OR USED FOR ANY LINES DOWNSTREAM.
- REMOVE THE ISOLATION MOUNT RESTRAINTS BEFORE THE INITIAL START. THE RESTRAINTS CAN BE DISCARDED.
- FIELD INSTALLED DUCTING TO AND FROM COMPRESSOR CANNOT ADD MORE THAN 6MM (.25 INCH) OF WATER TOTAL AIR RESISTANCE.
- UNIT HAS AN INTERNAL DISCHARGE CHECK VALVE, EXTERNAL CHECK VALVE NOT REQUIRED. ISOLATION VALVE REQUIRED WITHIN 915 MM (36 INCHES) OF THE COMPRESSOR DISCHARGE.
- COMPRESSOR SHOULD BE BOLTED TO THE FLOOR WITH FOUR M20 (3/4 INCH) BOLTS USING HOLES SHOWN ON SHEET 5. SEAL BASE TO FLOOR WITH CORK OR RUBBER.
- DO NOT PIPE INTO A COMMON HEADER WITH A RECIPROCATING COMPRESSOR. UNLESS RECIP COMPRESSOR UTILIZES A DISCHARGE PULSATION DAMPENER.
- ⊕ DENOTES CENTER OF GRAVITY.
- SIZING OF ELECTRICAL COMPONENTS NOT SUPPLIED BY INGERSOLL-RAND IS THE RESPONSIBILITY OF THE CUSTOMER AND SHOULD BE DONE IN ACCORDANCE WITH THE INFORMATION ON THE COMPRESSOR DATA PLATE, NATIONAL AND LOCAL ELECTRIC CODES.
- A BLANK GLAND PLATE IS PROVIDED FOR ELECTRICAL POWER INLET AS INDICATED.
- WHEN INSTALLED INDOORS IN A CONFINED SPACE, THE COOLING AIR INLET OR EXHAUST MUST BE DUCTED AWAY FROM UNIT TO PREVENT RECIRCULATION OF HOT EXHAUST AIR.

CONNECTION LEGEND

- ALL 60 Hz CONNECTIONS ARE NPT (UNLESS SPECIFIED OTHERWISE)
- ALL 50 Hz CONNECTIONS ARE BSPT (UNLESS SPECIFIED OTHERWISE)
- A. DISCHARGE AIR: 2.0 INCH (FEMALE)
- B. ELECTRICAL INLET: BLANK PLATE SUPPLIED
- C. PACKAGE AIR INLET (COMPRESSOR)
- D. PACKAGE AIR EXHAUST (COMPRESSOR)
- E. PACKAGE AIR INLET (DRYER)
- F. PACKAGE AIR EXHAUST (DRYER)
- G. CONDENSATE DRAIN (MOISTURE SEPARATOR): .375 INCH (FEMALE)  
THIS CONNECTION IS NOT USED ON NO MOISTURE SEPARATOR UNITS.
- H. CONDENSATE DRAIN (FILTER): .375 INCH (FEMALE)
- J. CONDENSATE DRAIN (DRYER): .375 INCH (FEMALE)
- K. WATER OUTLET: 1.50 INCH (FEMALE - ERS OPTION ONLY)
- L. WATER INLET: 1.50 INCH (FEMALE - ERS OPTION ONLY)

GENERAL ARRANGEMENT TOLERANCES	WARNING: THE EXPORT OR REEXPORT OF THIS DRAWING OR A PRODUCT PRODUCED BY THIS DRAWING IS SUBJECT TO U.S. EXPORT ADMINISTRATION REGULATIONS AND OTHER APPLICABLE GOVERNMENT RESTRICTIONS OR REGULATIONS.
	PROPRIETARY NOTICE THIS DRAWING CONTAINS CONFIDENTIAL AND TRADE SECRET INFORMATION, IS THE PROPERTY OF INGERSOLL-RAND CO., AND IS GIVEN TO THE RECEIVER IN CONFIDENCE. THE RECEIVER BY RECEPTION AND RETENTION OF THE DRAWING ACCEPTS THE DRAWING IN CONFIDENCE AND AGREES THAT, EXCEPT AS AUTHORIZED IN WRITING BY INGERSOLL-RAND CO. IT WILL (1) NOT USE THE DRAWING OR ANY COPY THEREOF OR THE CONFIDENTIAL OR TRADE SECRET INFORMATION THEREIN; (2) NOT COPY THE DRAWING; (3) NOT DISCLOSE TO OTHERS EITHER THE DRAWING OR THE CONFIDENTIAL OR TRADE SECRET INFORMATION THEREIN; AND (4) UPON COMPLETION OF THE NEED TO RETAIN THE DRAWING, OR UPON DEMAND, RETURN THE DRAWING, ALL COPIES THEREOF, AND ALL MATERIAL COPIED THEREFROM.
ALL DIMENSIONS ARE IN MILLIMETERS [INCHES (IF SHOWN)]	
UNSPECIFIED TOLERANCES:	
WHOLE : ± 13.0[.50]	
X : ± 6.0[.25]	
ANGLES : ± 1°	
Ingersoll-Rand Industrial Technologies	

DO NOT SCALE DRAWING DRAWING CONFORMS TO ASME Y14.5M - 1994
CAD GENERATED DRAWING. NO MANUAL REVISIONS ALLOWED
UNLESS OTHERWISE SPECIFIED: - REMOVE ALL BURRS AND SHARP CORNERS - WELD SYMBOLS TO BE IN ACCORDANCE WITH ANSI/AWS A2.4
COPYRIGHT @ 2018 Ingersoll Rand ALL RIGHTS RESERVED

THIRD ANGLE PROJECTION	
DRAWN T.WU	DATE 2017JUL03
CHECKED P.JIN	DATE 2017JUL03
APPROVED XH.ZHONG	DATE 2017JUL03
DRAWING TYPE General Arrangement Drawing	
NOMENCLATURE	



**GENERAL ARRANGEMENT DRAWING,  
AIR COOLED (RS45-75I)**

NAME	GENERAL ARRANGEMENT DRAWING, AIR COOLED (RS45-75I)			REVISION	C
SIZE	A1	ESTIMATED WEIGHT (KG UNLESS OTHERWISE SPECIFIED)	DWG NO.	47613761001	
SCALE	0.15	MODEL	PART NO.	RS45-75	SHEET 1 of 9

8 7 6 5 4 3 2 1

D  
C  
B  
A

D  
C  
B  
A

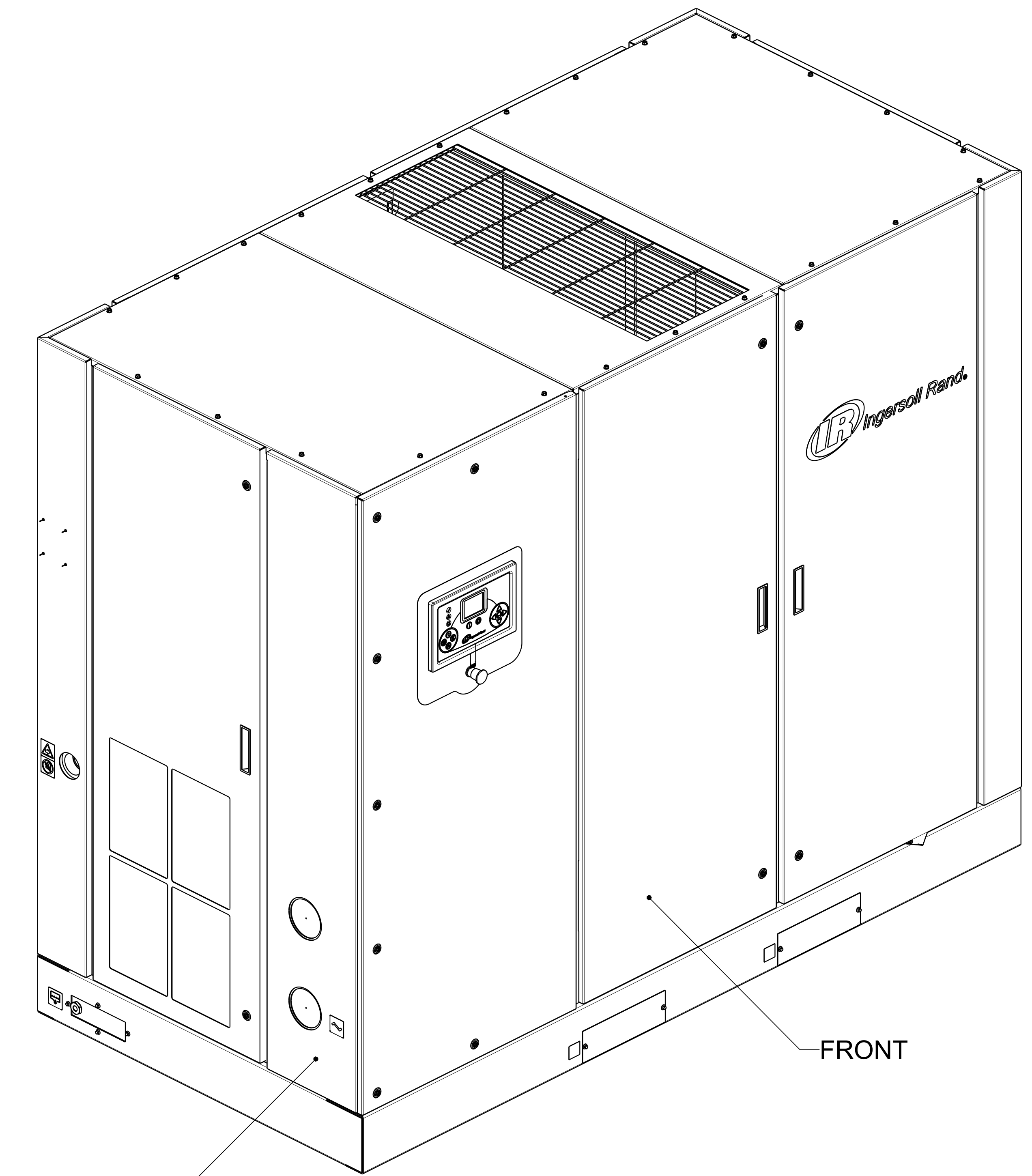

LEFT END

FRONT

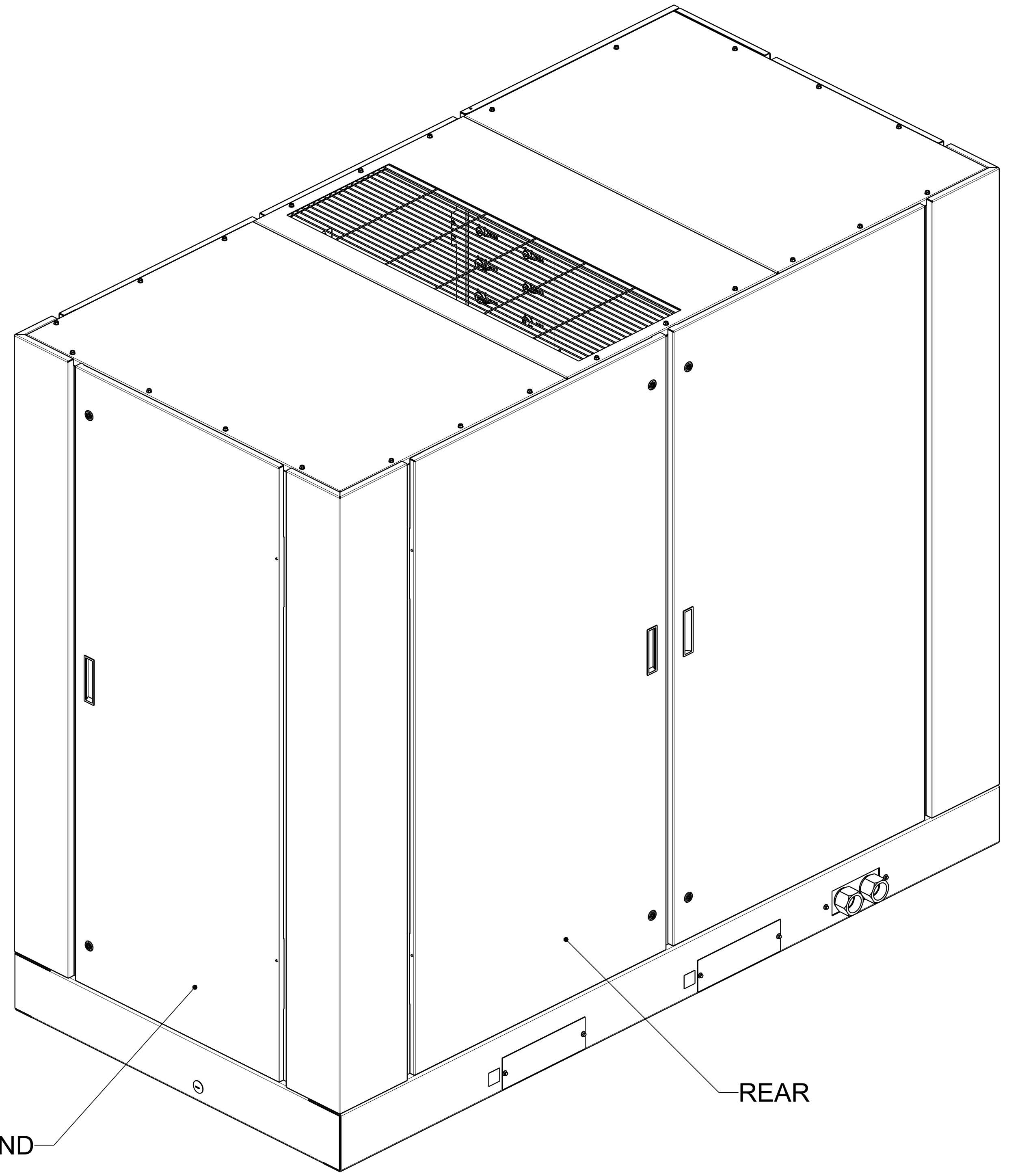

RIGHT END

REAR

<small>PROPRIETARY NOTICE</small> <small>THIS DRAWING CONTAINS CONFIDENTIAL AND TRADE SECRET INFORMATION. IS THE PROPERTY OF INGERSOLL-RAND CO. AND IS GIVEN TO THE RECEIVER IN CONFIDENCE. THE RECEIVER BY RECEIPT AND RETENTION OF THE DRAWING ACCEPTS THE DRAWING IN CONFIDENCE AND AGREES THAT, EXCEPT AS AUTHORIZED IN WRITING BY INGERSOLL-RAND CO. IT WILL (1) NOT USE THE DRAWING OR ANY COPY THEREOF OR THE CONFIDENTIAL OR TRADE SECRET INFORMATION THEREIN, (2) NOT COPY THE DRAWING, (3) NOT DISCLOSE TO OTHERS EITHER THE DRAWING OR THE CONFIDENTIAL OR TRADE SECRET INFORMATION THEREIN, AND (4) UPON COMPLETION OF THE NEED TO RETAIN THE DRAWING, OR UPON DEMAND, RETURN THE DRAWING, ALL COPIES THEREOF, AND ALL MATERIAL COPIED THEREFROM.</small>		<small>NAME</small> <b>GENERAL ARRANGEMENT DRAWING, AIR COOLED (RS45-75I)</b>	
<small>SIZE</small> <b>A1</b>	<small>DWG NO.</small> <b>47613761001</b>	<small>REVISION</small> <b>C</b>	
<small>SCALE</small> 0.13	<small>NOMENCLATURE</small>	<small>SHEET</small> 2 of 9	

8 7 6 5 4 3 2 1

# OPTION: NO DRYER

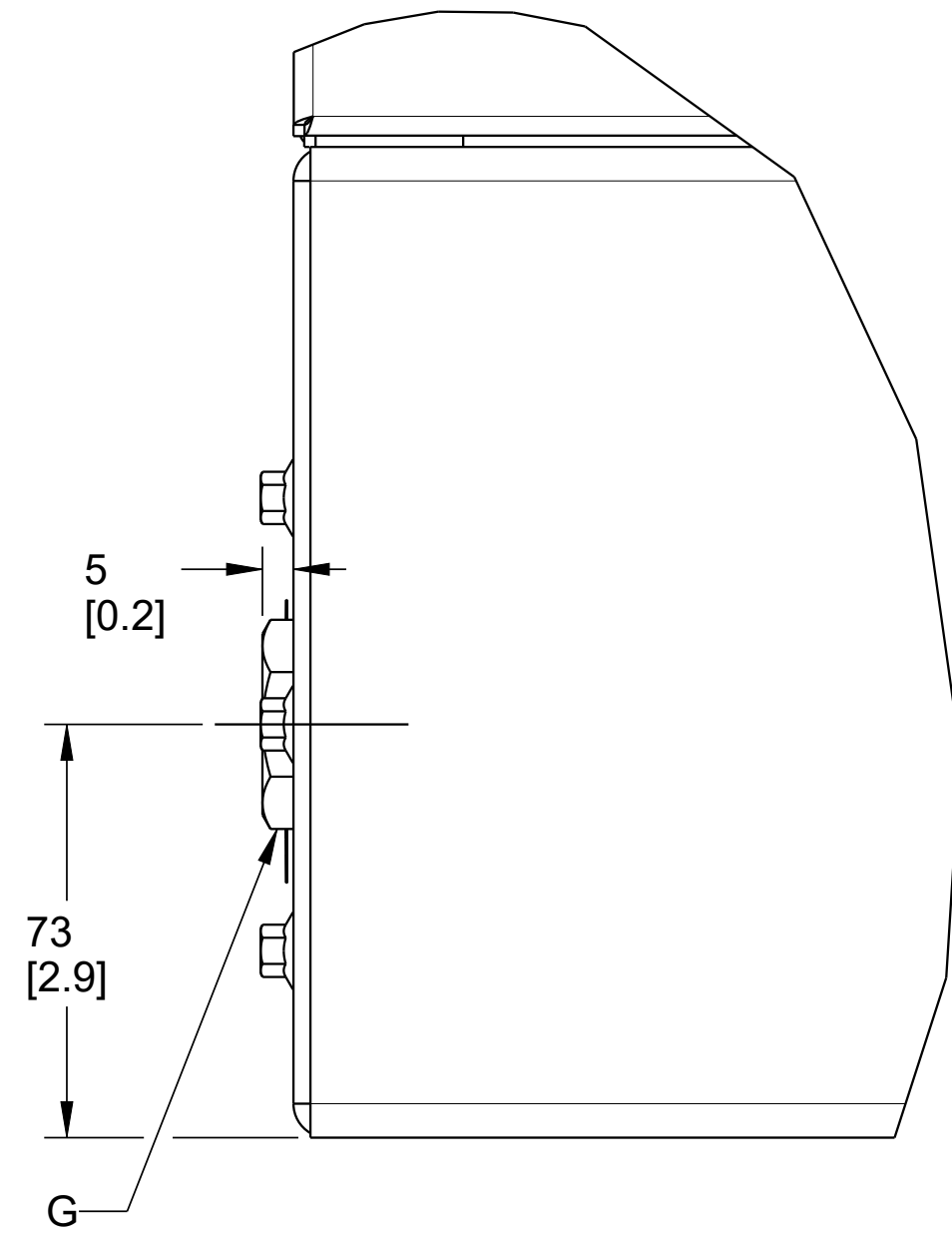

DETAIL A  
SCALE 0.750

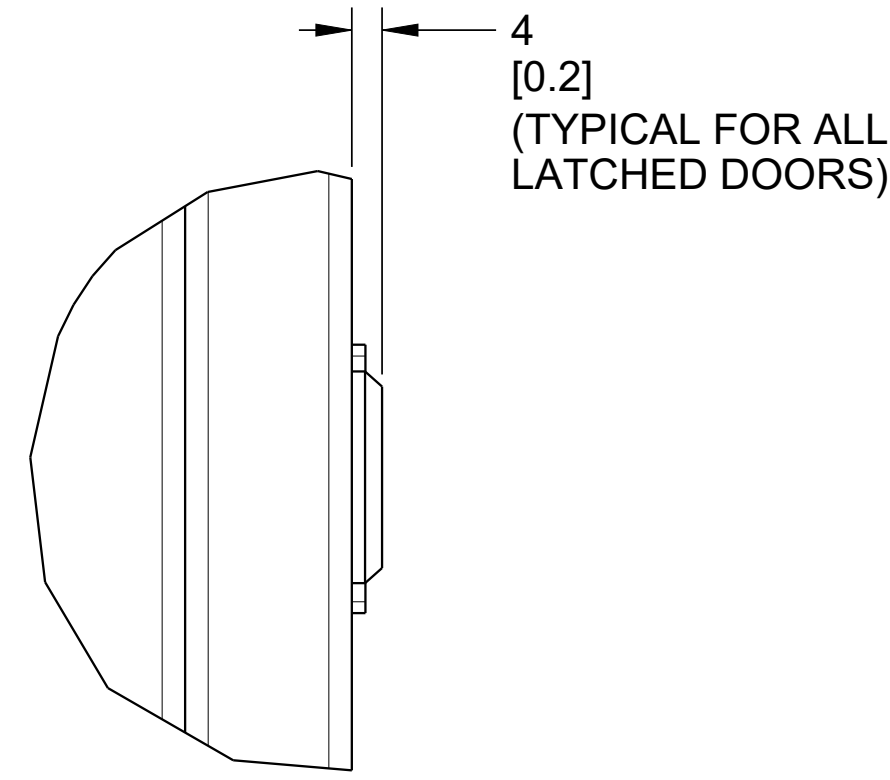

DETAIL E  
SCALE 1.000

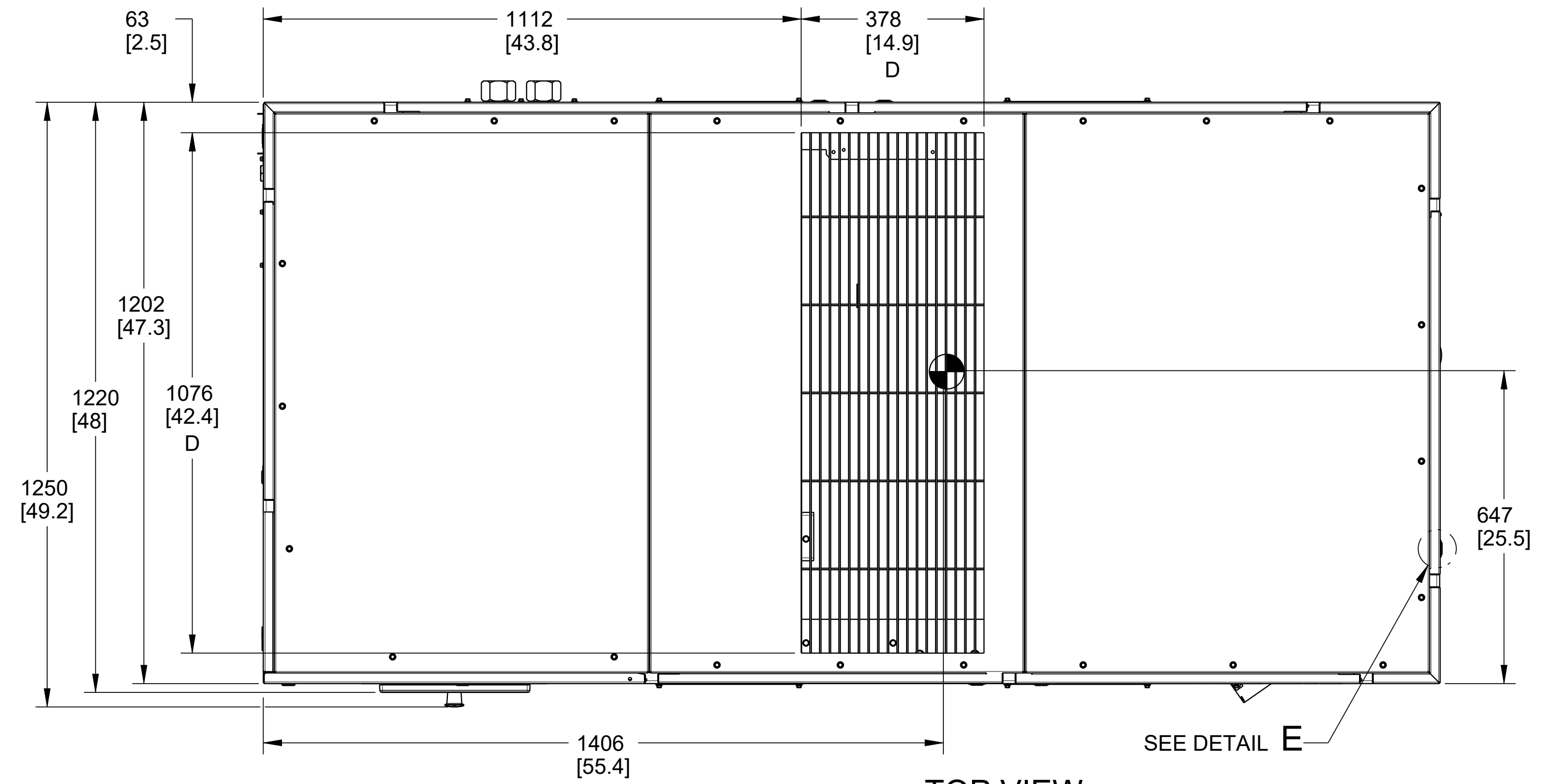

TOP VIEW

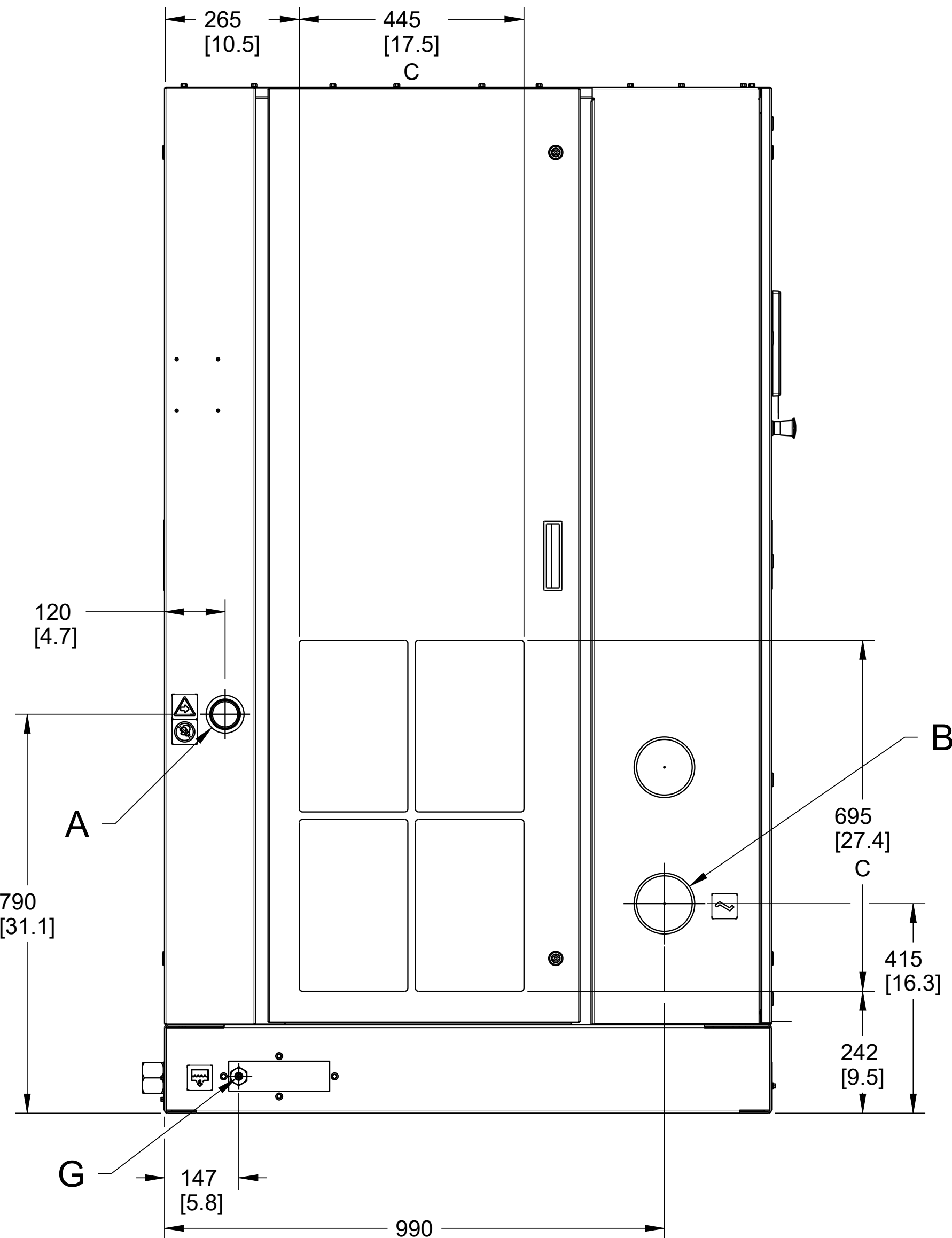

LEFT END VIEW

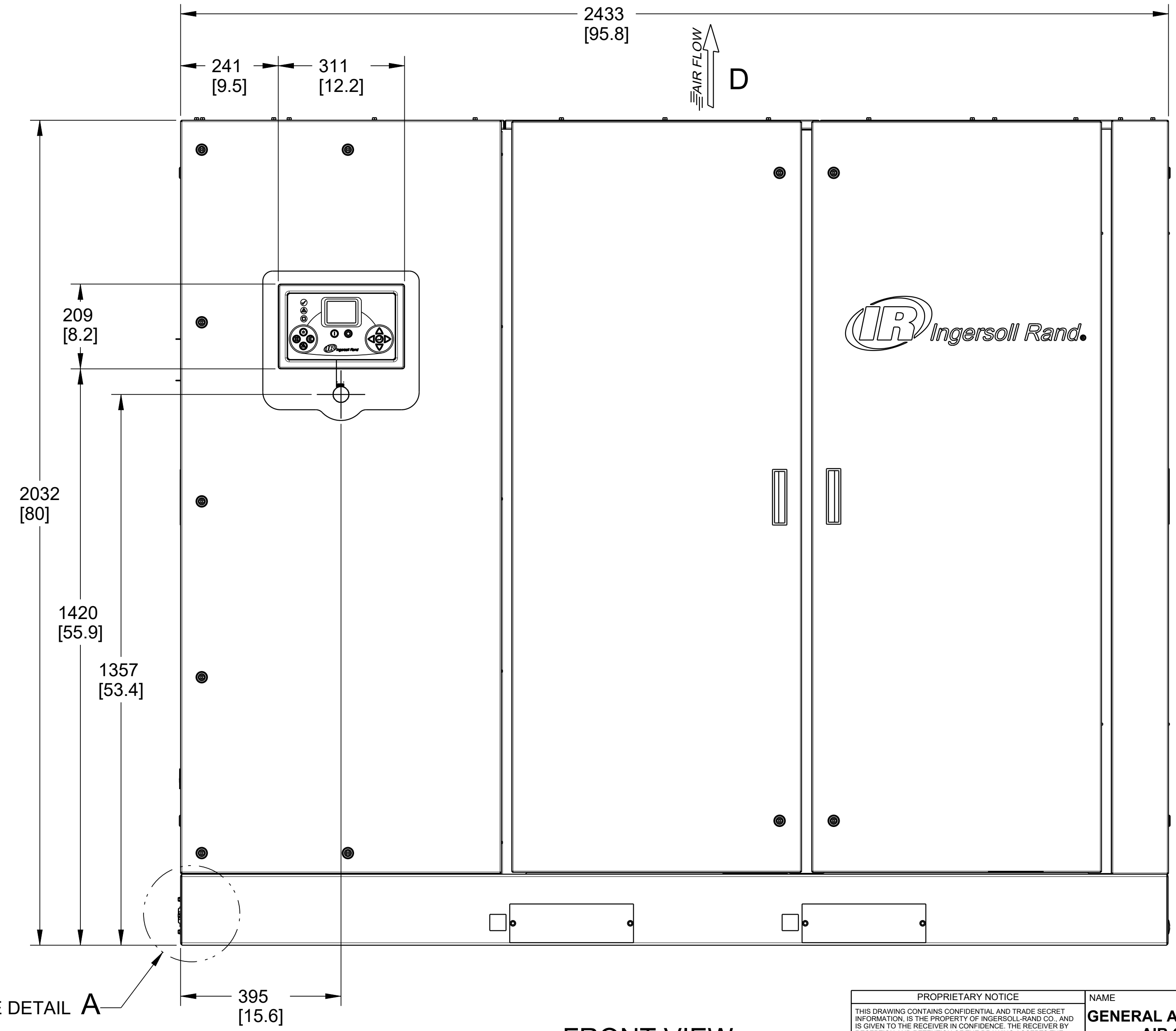

FRONT VIEW

<small>PROPRIETARY NOTICE</small> <small>THIS DRAWING CONTAINS CONFIDENTIAL AND TRADE SECRET INFORMATION. IT IS THE PROPERTY OF INGERSOLL-RAND CO. AND IS GIVEN TO THE RECEIVER IN CONFIDENCE. THE RECEIVER BY RECEIPT AND RETENTION OF THIS DRAWING ACCEPTS THE DRAWING IN CONFIDENCE AND AGREES THAT, EXCEPT AS AUTHORIZED IN WRITING BY INGERSOLL-RAND CO., IT WILL (1) NOT USE THE DRAWING OR ANY COPY THEREOF OR THE CONFIDENTIAL OR TRADE SECRET INFORMATION THEREIN, (2) NOT COPY THE DRAWING, (3) NOT DISCLOSE TO OTHERS EITHER THE DRAWING OR THE CONFIDENTIAL OR TRADE SECRET INFORMATION THEREIN, AND (4) UPON COMPLETION OF THE NEED TO RETAIN THE DRAWING, OR UPON DEMAND, RETURN THE DRAWING, ALL COPIES THEREOF, AND ALL MATERIAL COPIED THEREFROM.</small>		<small>NAME</small> <b>GENERAL ARRANGEMENT DRAWING, AIR COOLED (RS45-75I)</b>	
<small>SIZE</small> <b>A1</b>	<small>DWG NO.</small> <b>47613761001</b>	<small>REVISION</small> <b>C</b>	
<small>SCALE</small> 0.13	<small>NOMENCLATURE</small>	<small>SHEET</small> 3 OF 9	

# OPTION: WITH DRYER

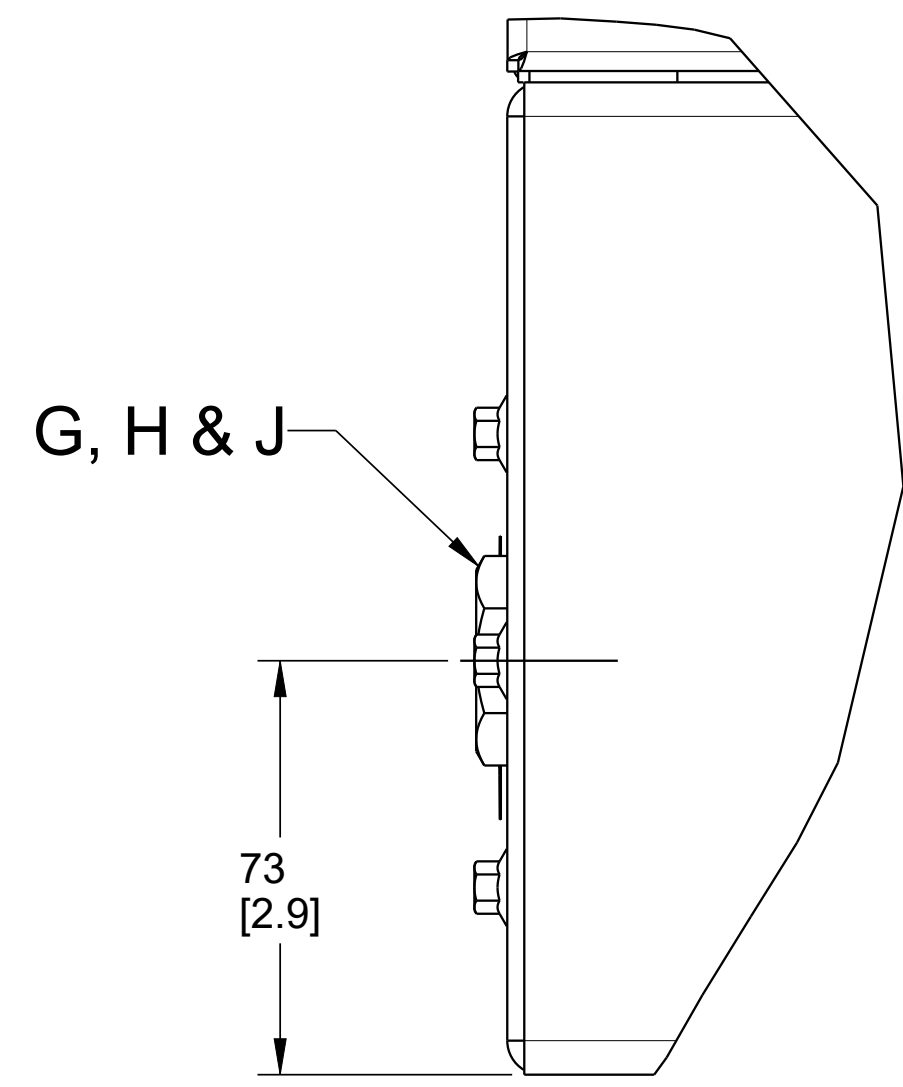

DETAIL F  
SCALE 0.750

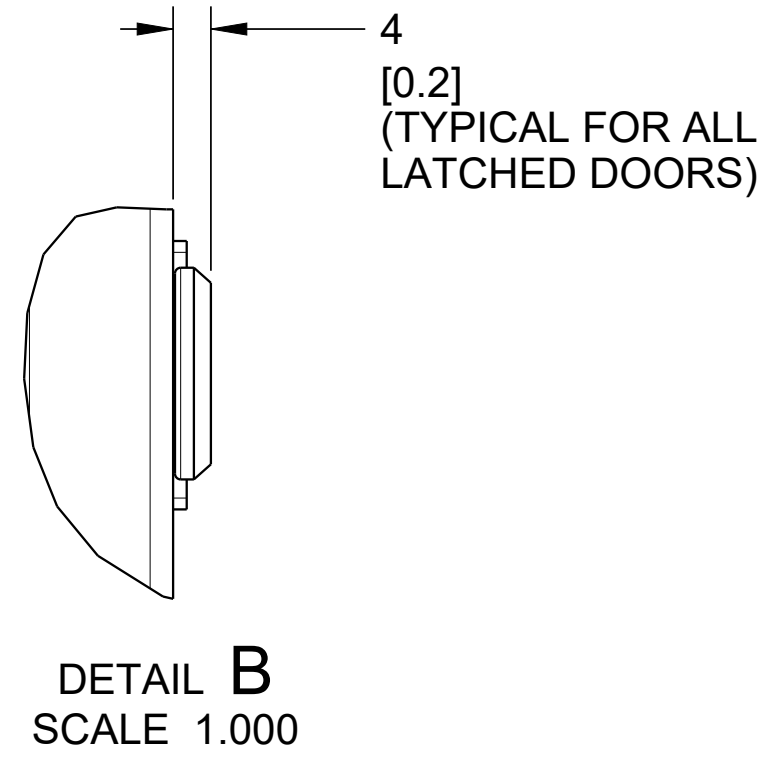

DETAIL B  
SCALE 1.000

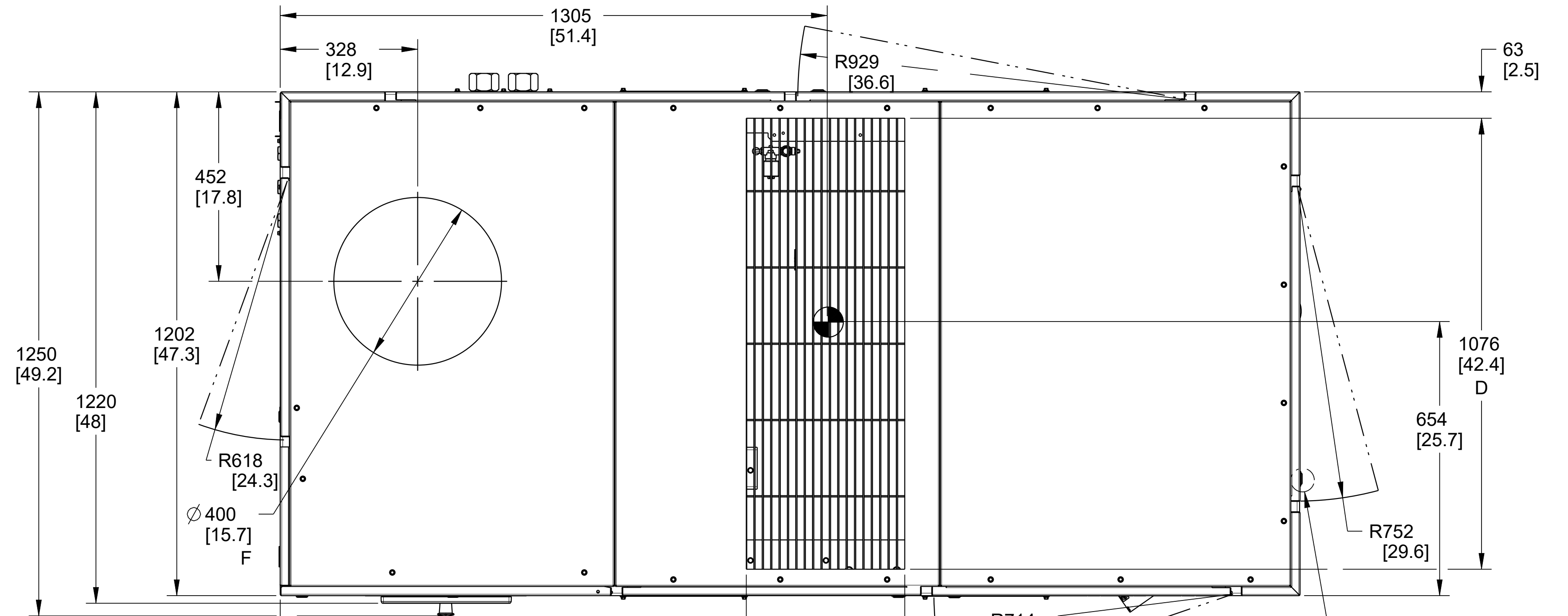

TOP VIEW

SEE DETAIL B

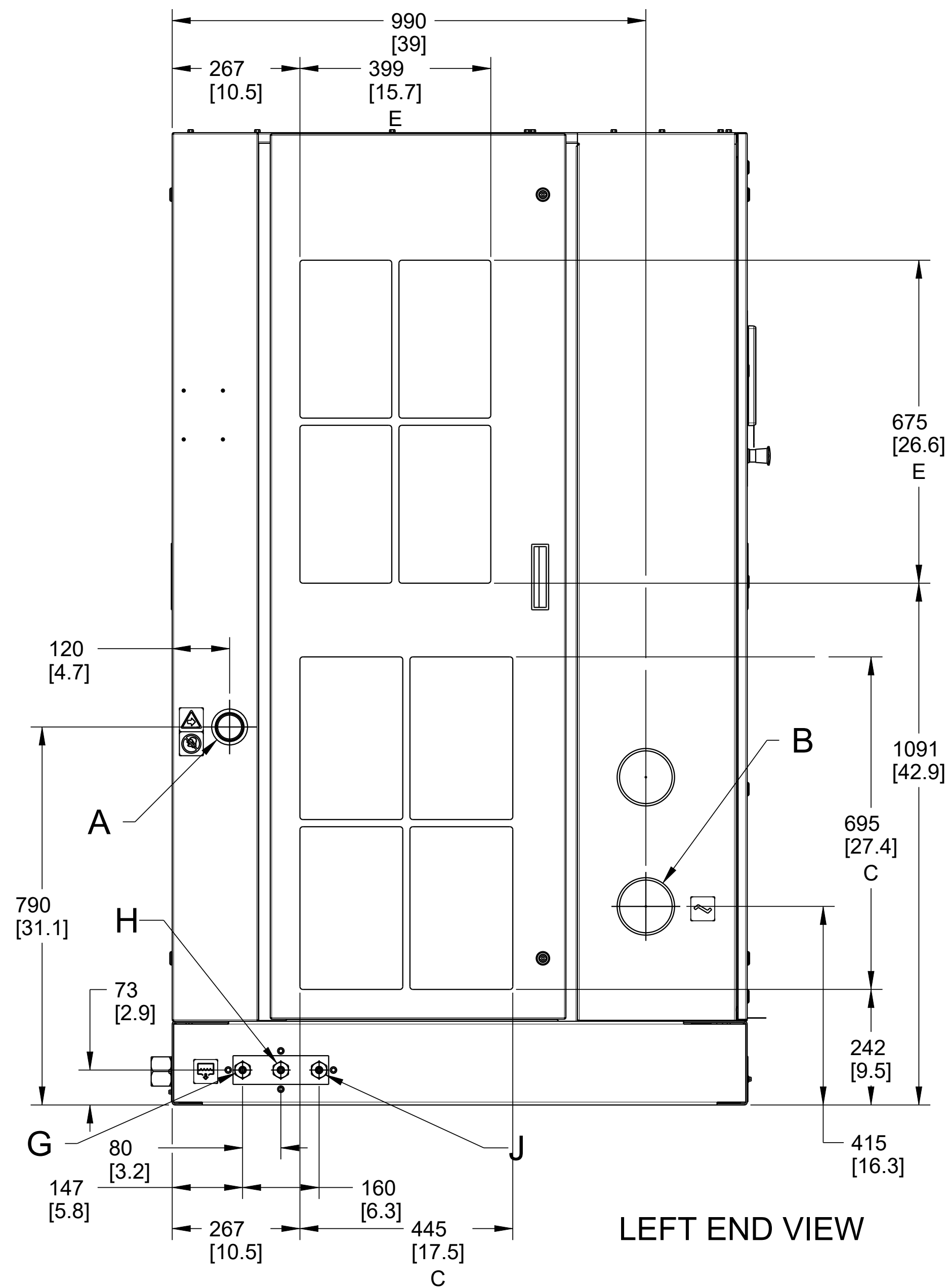

LEFT END VIEW

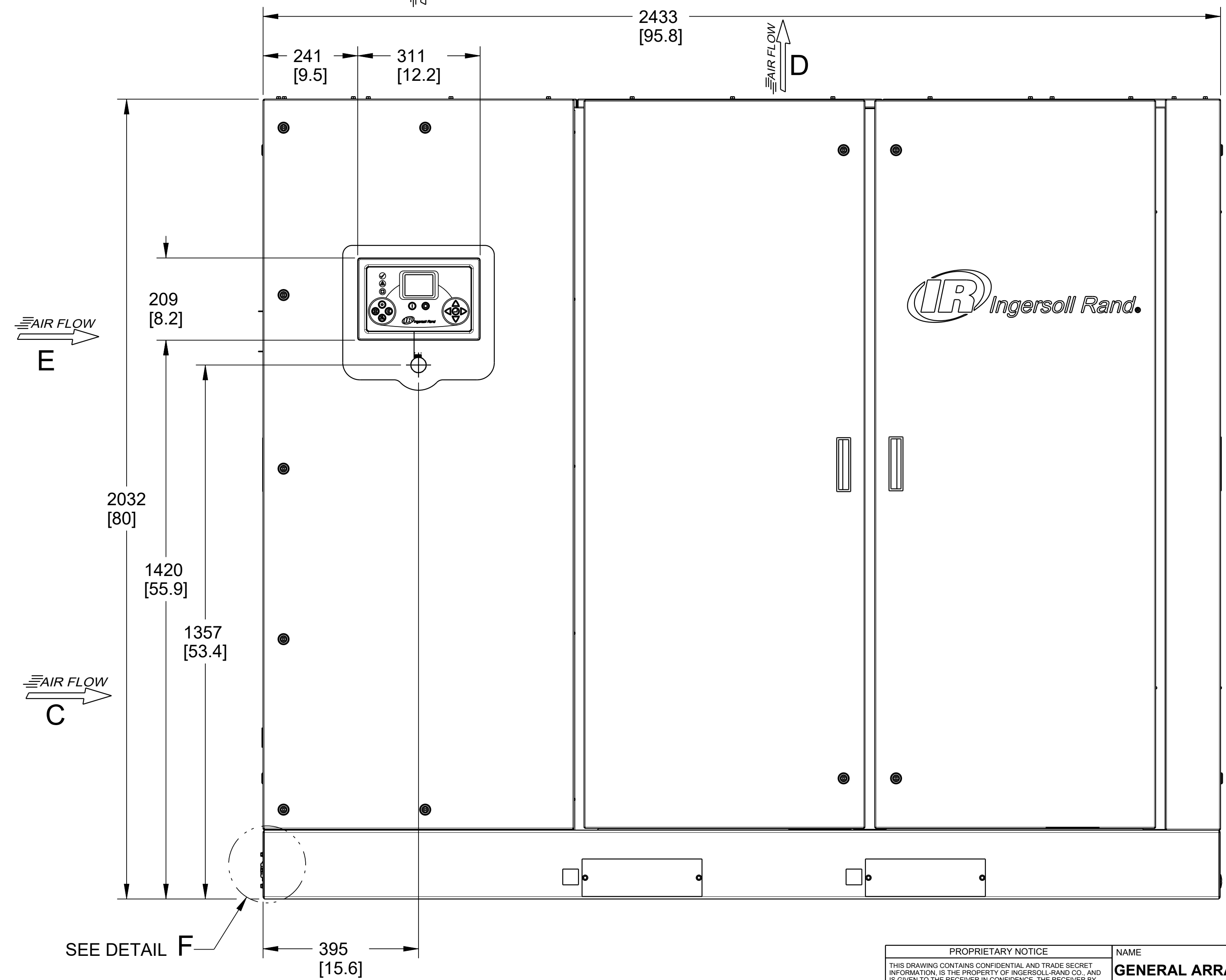

FRONT VIEW

<small>PROPRIETARY NOTICE</small> <small>THIS DRAWING CONTAINS CONFIDENTIAL AND TRADE SECRET INFORMATION IS THE PROPERTY OF INGERSOLL-RAND CO. AND IS GIVEN TO THE RECEIVER IN CONFIDENCE. THE RECEIVER BY RECEIPT AND RETENTION OF THE DRAWING ACCEPTS THE DRAWING IN CONFIDENCE AND AGREES THAT, EXCEPT AS AUTHORIZED IN WRITING BY INGERSOLL-RAND CO., IT WILL (1) NOT USE THE DRAWING OR ANY COPY THEREOF OR THE CONFIDENTIAL OR TRADE SECRET INFORMATION THEREIN, (2) NOT COPY THE DRAWING, (3) NOT DISCLOSE TO OTHERS EITHER THE DRAWING OR THE CONFIDENTIAL OR TRADE SECRET INFORMATION THEREIN, AND (4) UPON COMPLETION OF THE NEED TO RETAIN THE DRAWING OR UPON DEMAND, RETURN THE DRAWING, ALL COPIES THEREOF, AND ALL MATERIAL COPIED THEREFROM.</small>		<small>NAME</small> <b>GENERAL ARRANGEMENT DRAWING, AIR COOLED (RS45-75I)</b>	
<small>SIZE</small> <b>A1</b>	<small>DWG NO.</small> <b>47613761001</b>	<small>REVISION</small> <b>C</b>	
<small>SCALE</small> <b>0.13</b>	<small>NOMENCLATURE</small>	<small>SHEET</small> <b>4 OF 9</b>	

8 7 6 5 4 3 2 1

D  
C  
B  
A

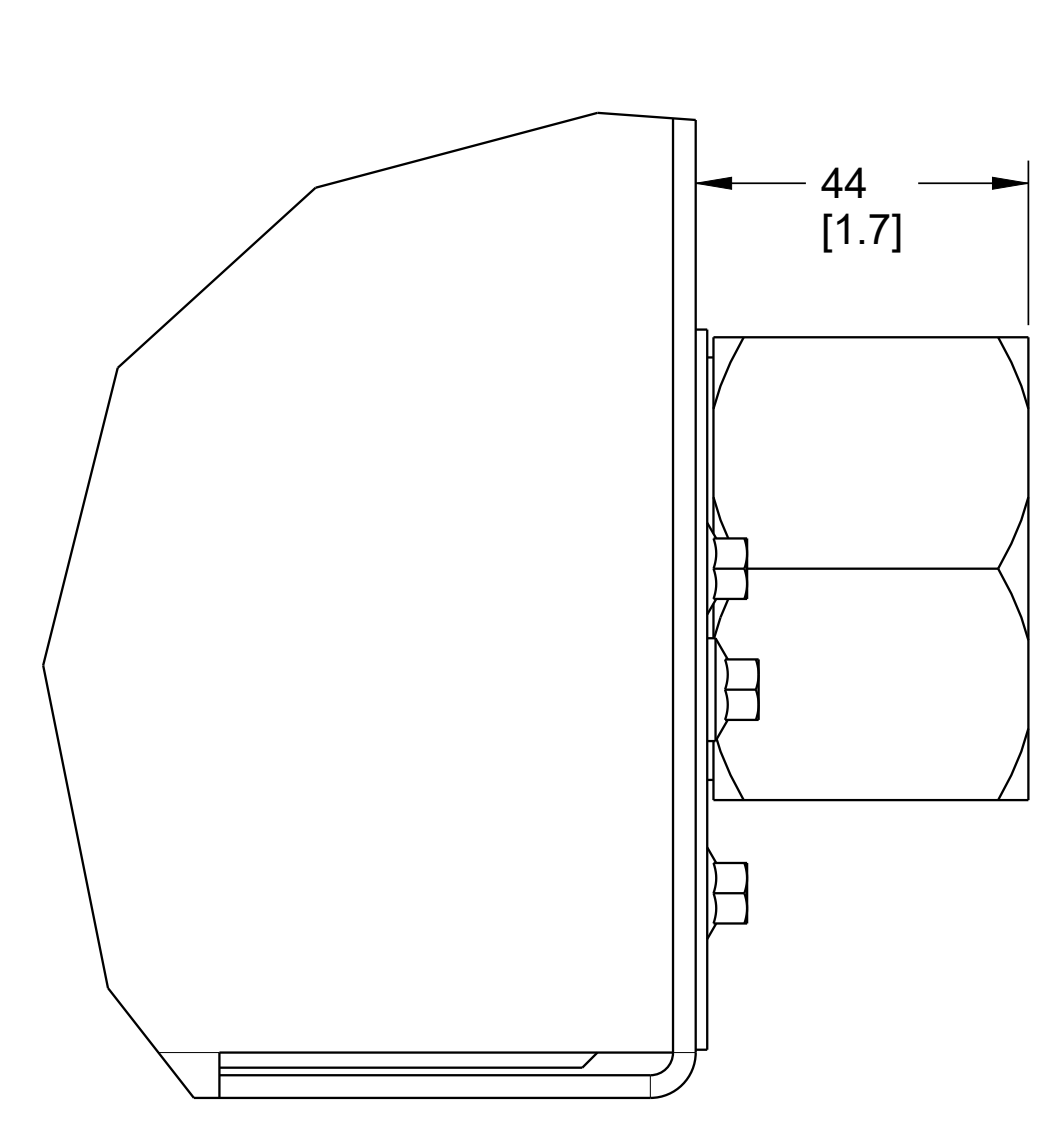
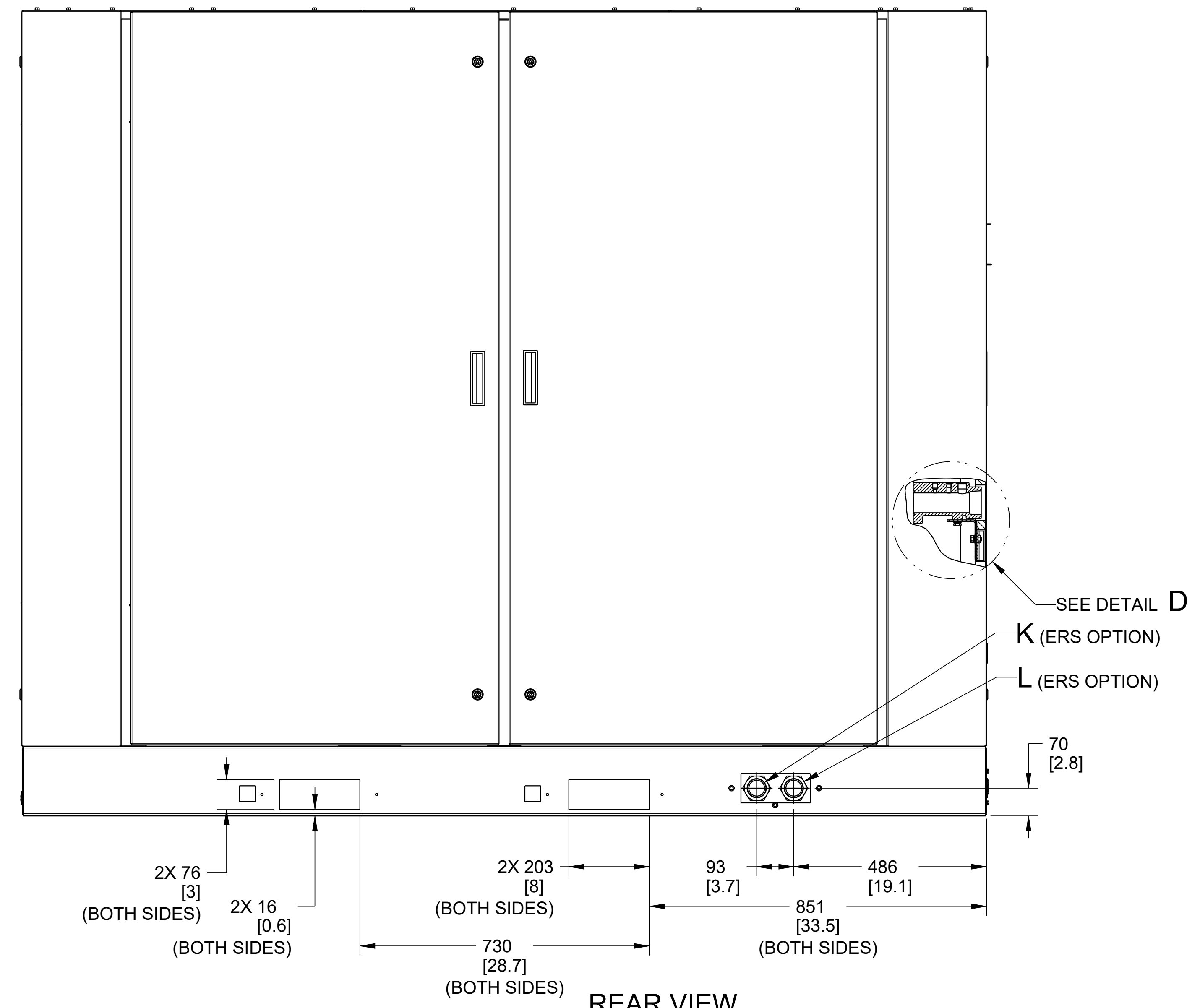
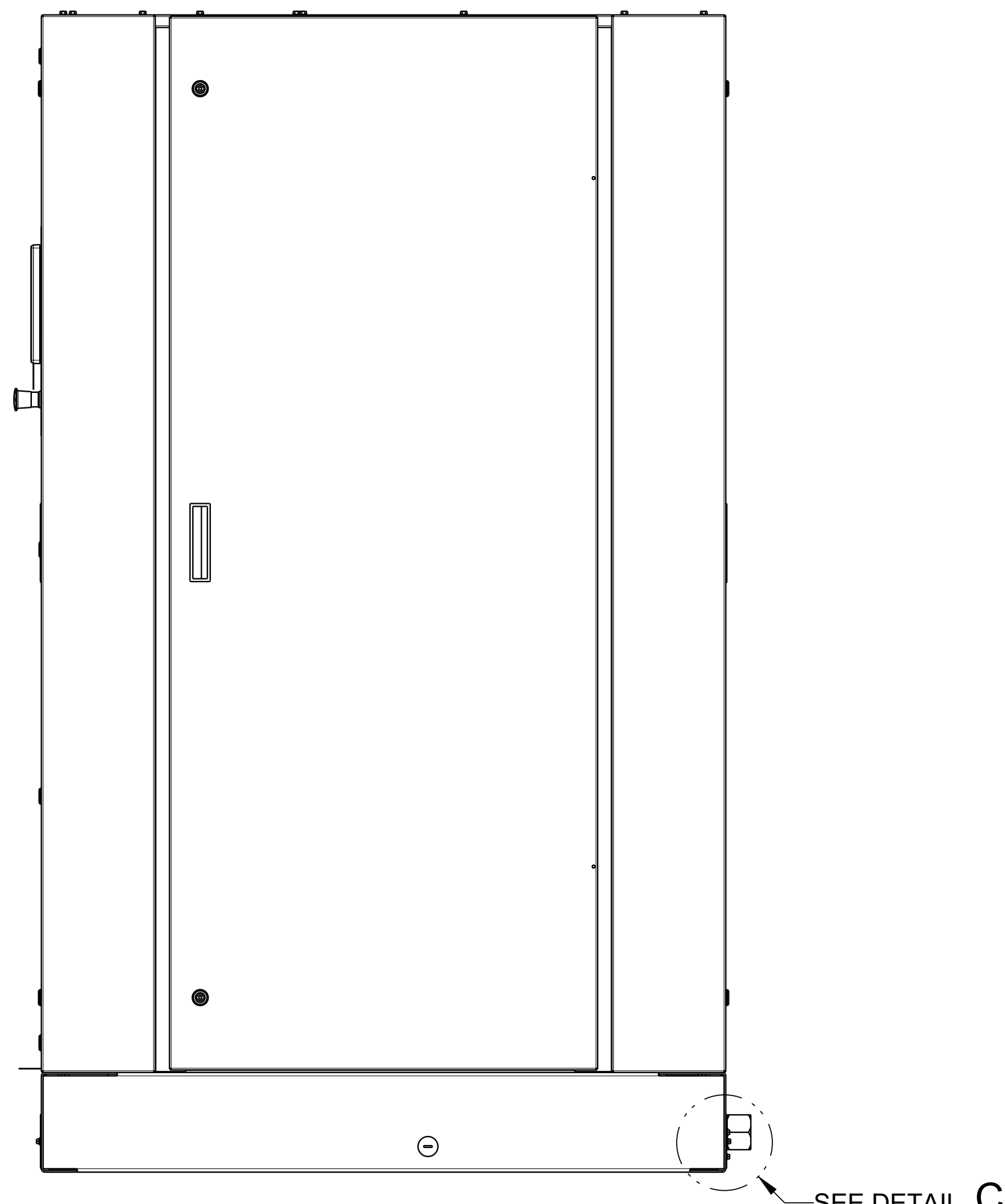

**DETAIL C**  
SCALE 1.000  
(ERS OPTION ONLY)

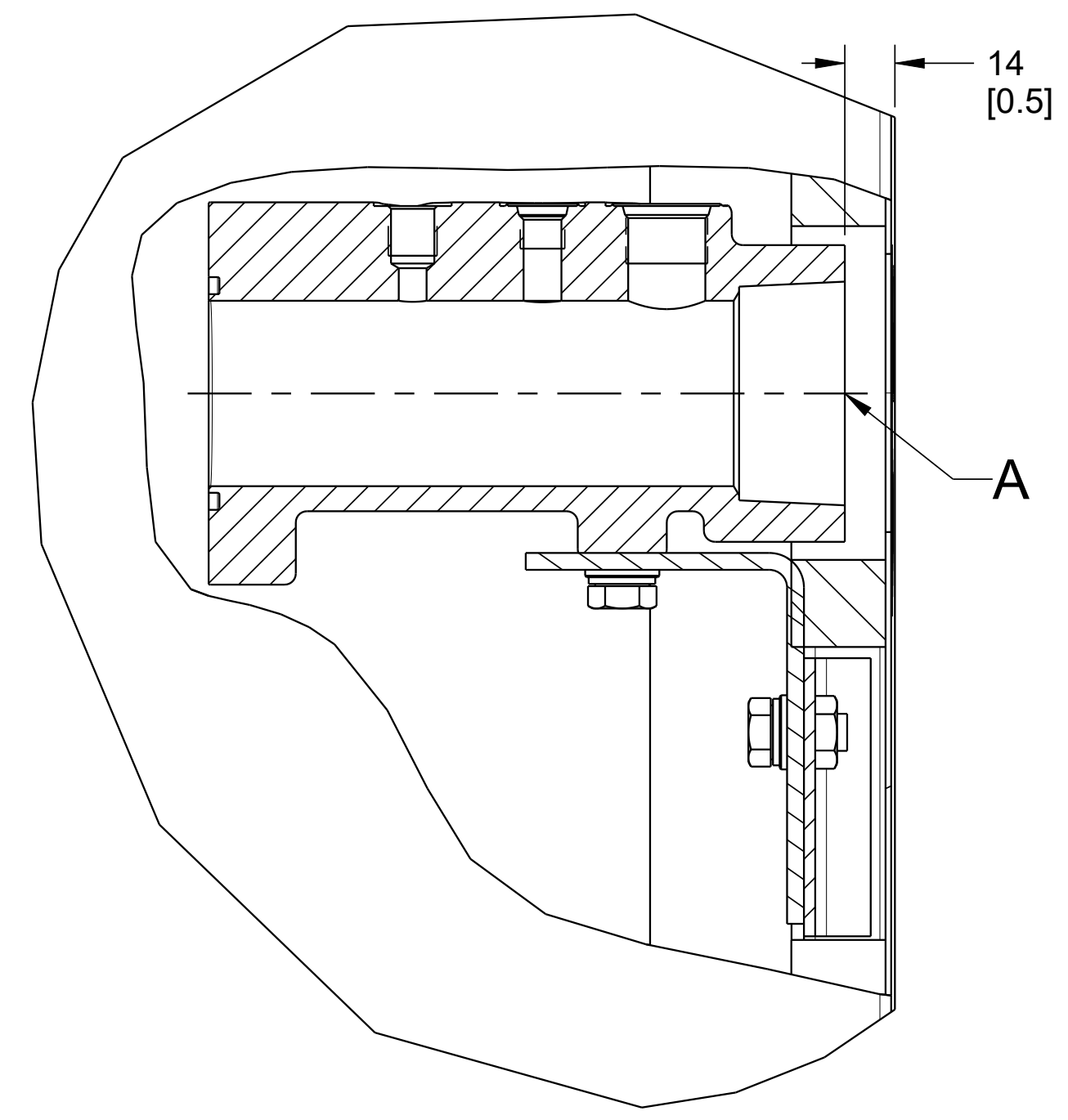

**DETAIL D**  
SCALE 0.600

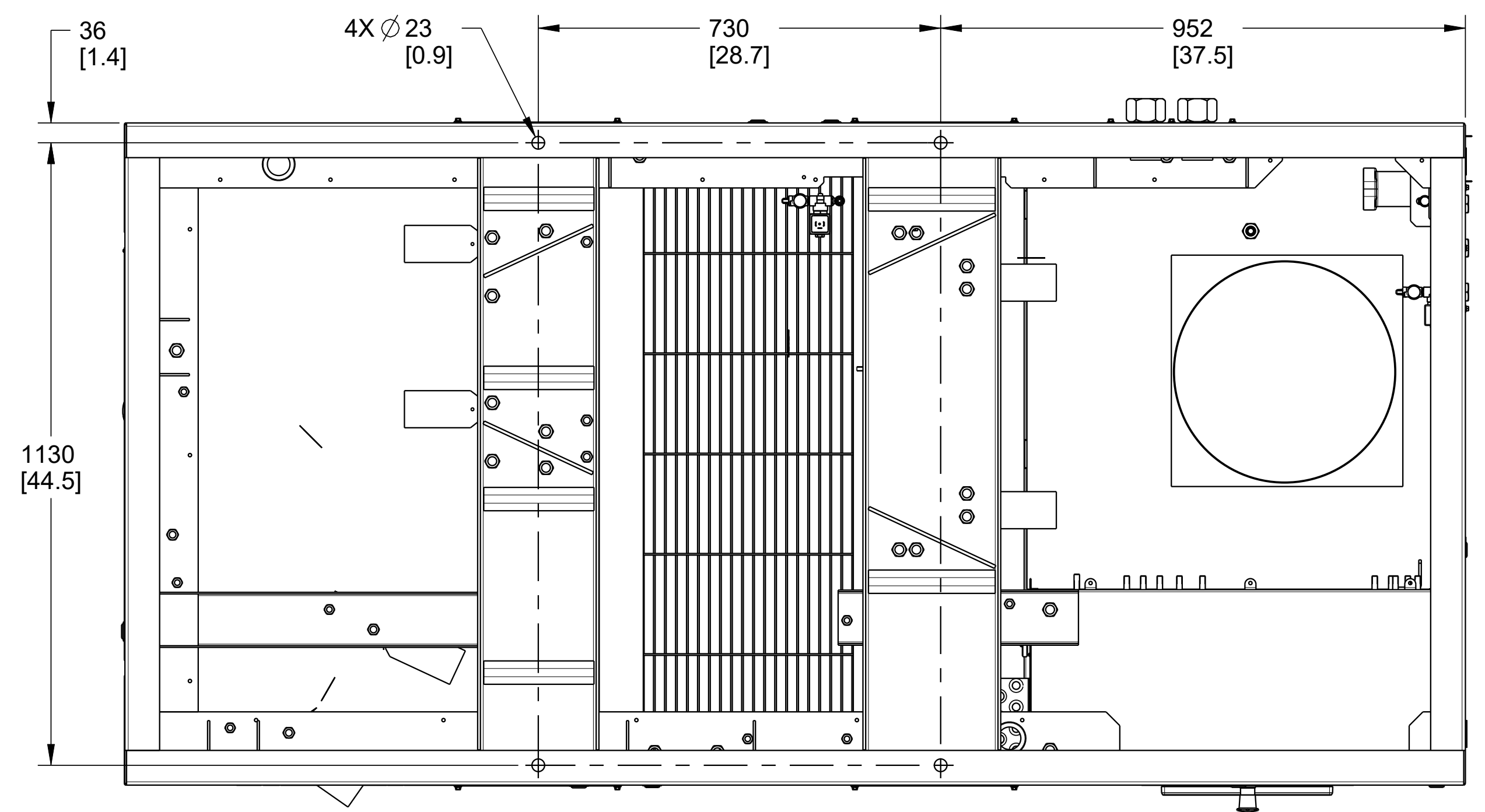

<small>PROPRIETARY NOTICE</small> <small>THIS DRAWING CONTAINS CONFIDENTIAL AND TRADE SECRET INFORMATION. IS THE PROPERTY OF INGERSOLL-RAND CO. AND IS GIVEN TO THE RECEIVER IN CONFIDENCE. THE RECEIVER BY RECEIPT AND RETENTION OF THIS DRAWING ACCEPTS THE DRAWING IN CONFIDENCE AND AGREES THAT, EXCEPT AS AUTHORIZED IN WRITING BY INGERSOLL-RAND CO., IT WILL (1) NOT USE THE DRAWING OR ANY COPY THEREOF OR THE CONFIDENTIAL OR TRADE SECRET INFORMATION THEREIN; (2) NOT COPY THE DRAWING; (3) NOT DISCLOSE TO OTHERS EITHER THE DRAWING OR THE CONFIDENTIAL OR TRADE SECRET INFORMATION THEREIN; AND (4) UPON COMPLETION OF THE NEED TO RETAIN THE DRAWING, OR UPON DEMAND, RETURN THE DRAWING, ALL COPIES THEREOF, AND ALL MATERIAL COPIED THEREFROM.</small>		<small>NAME</small> <b>GENERAL ARRANGEMENT DRAWING, AIR COOLED (RS45-75I)</b>	
<small>SIZE</small> <b>A1</b>	<small>DWG NO.</small> <b>47613761001</b>	<small>REVISION</small> <b>C</b>	
<small>SCALE</small> 0.13	<small>NOMENCLATURE</small>	<small>SHEET</small> 5 of 9	

8 7 6 5 4 3 2 1

# GENERAL ARRANGEMENT WITH OPTIONAL OUTDOOR MODIFICATION (OPTION IS NOT AVAILABLE FOR DRYER OR VSD UNITS)

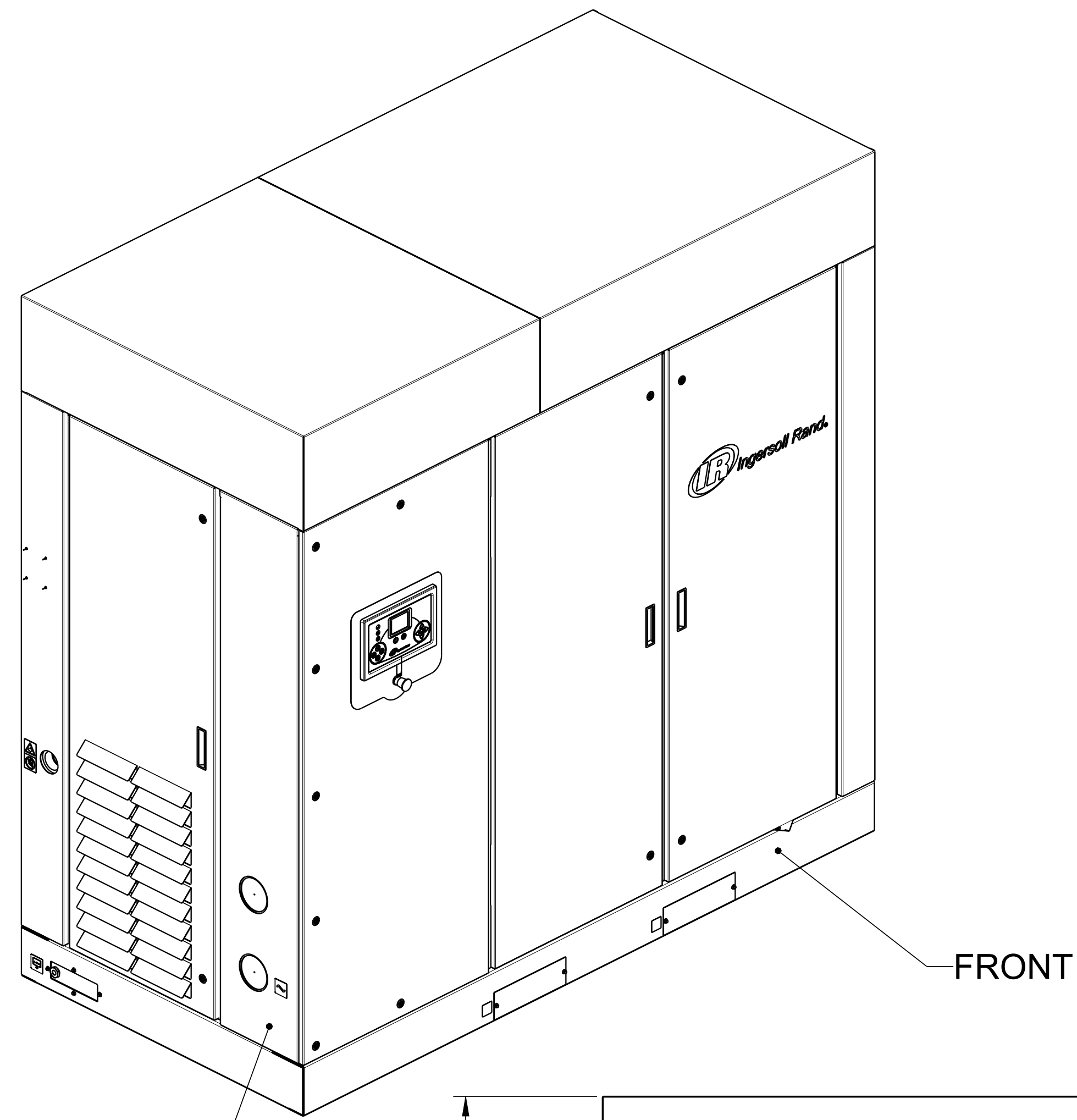

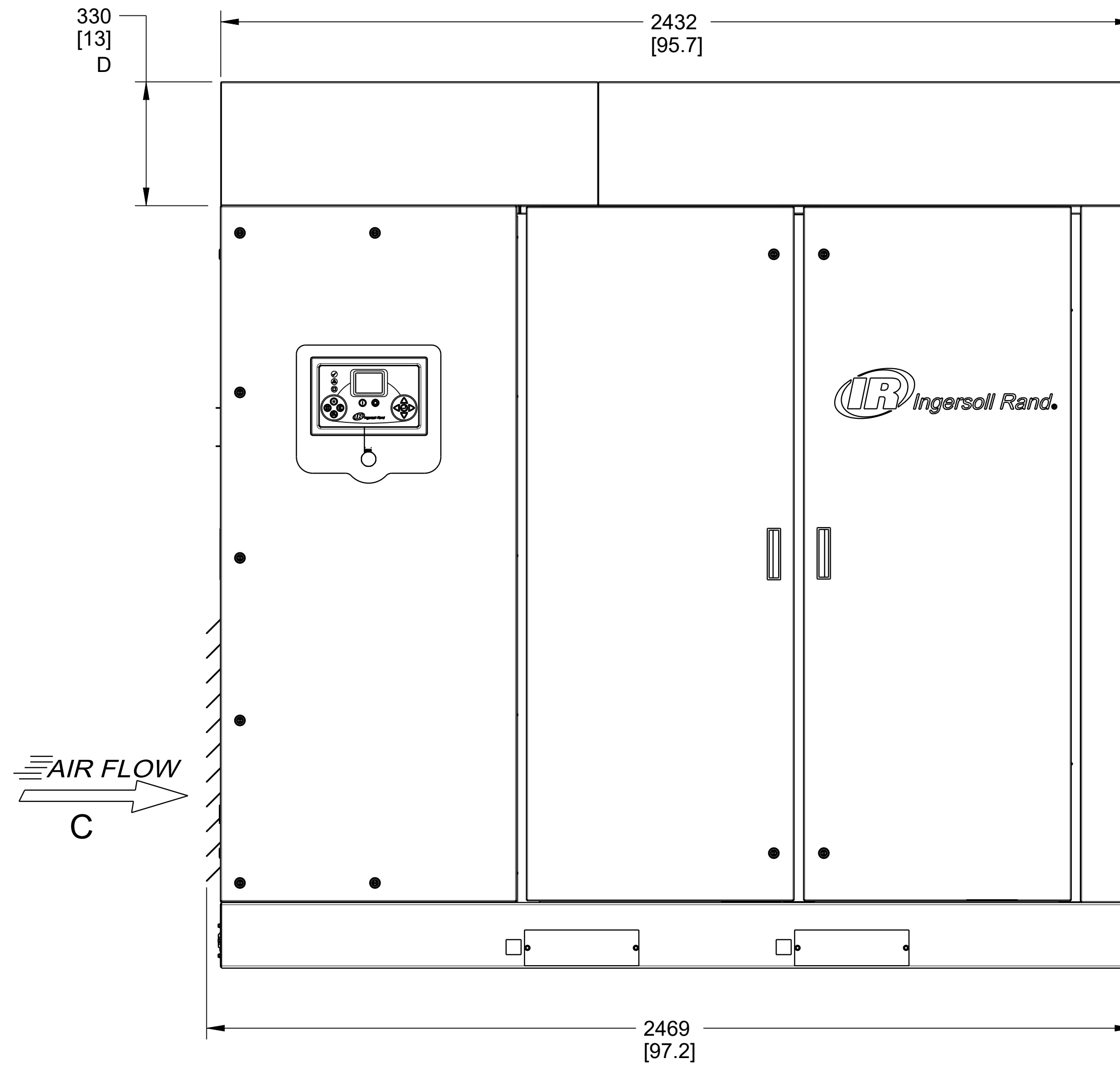
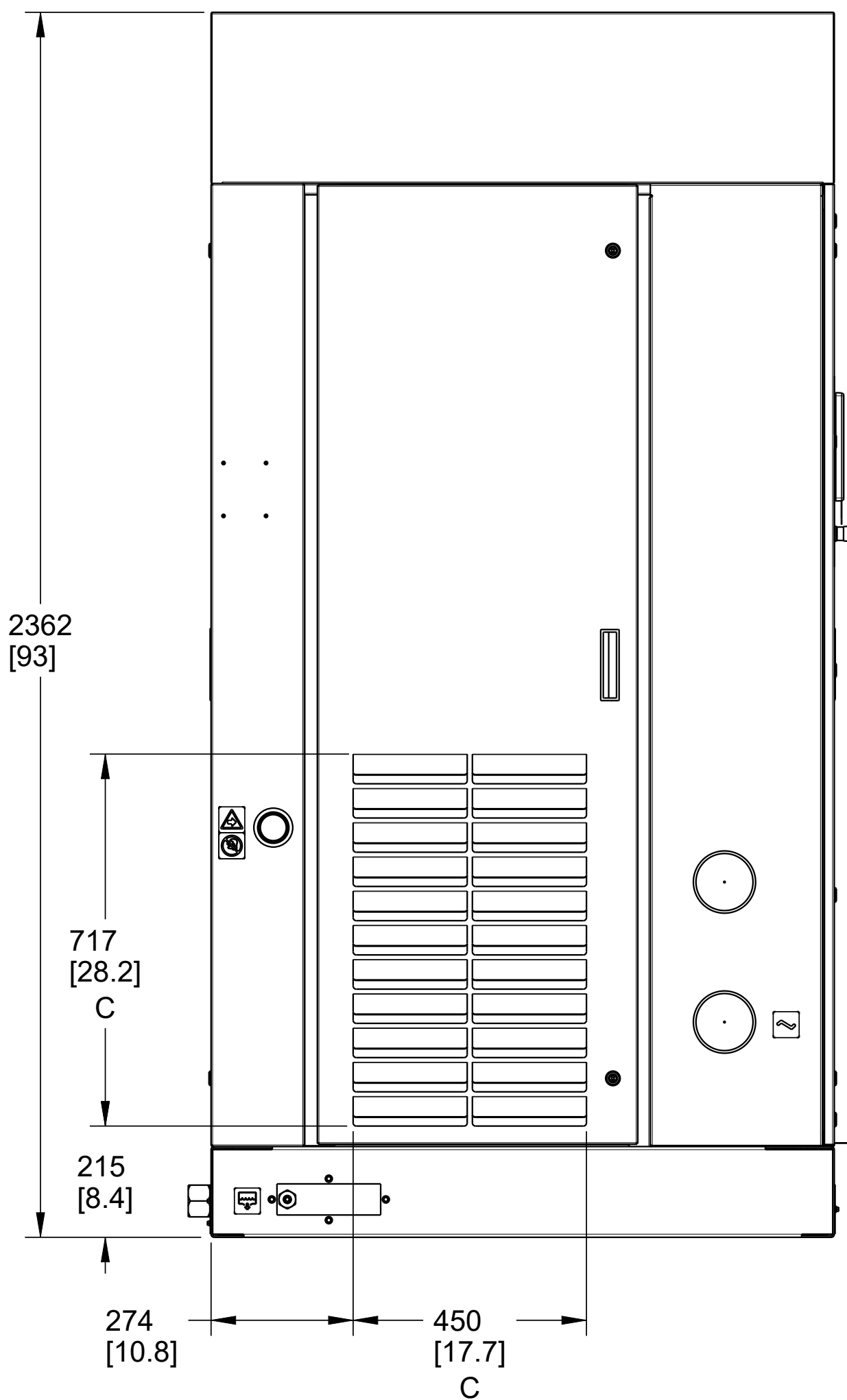

FRONT

LEFT END

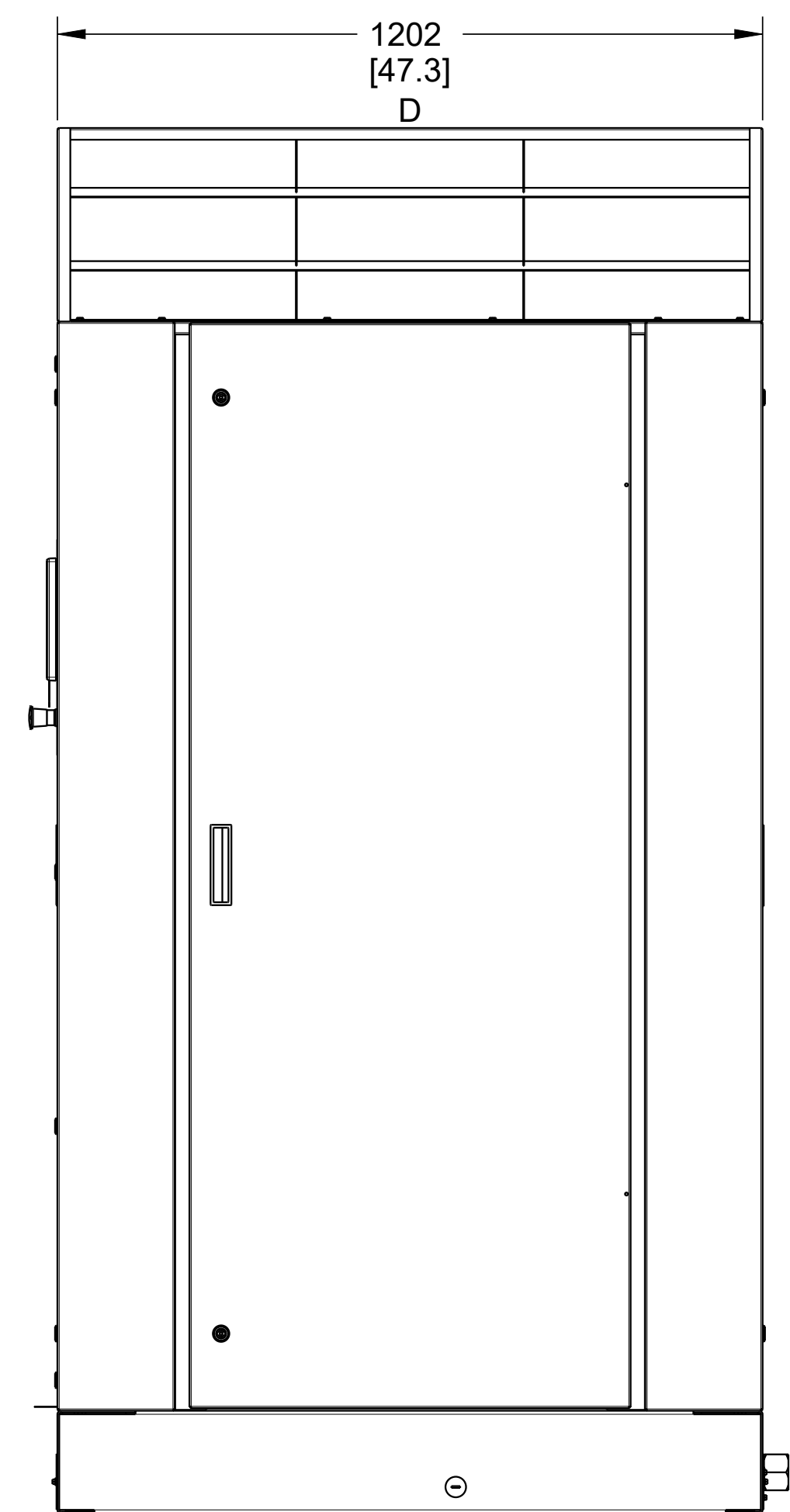

AIR FLOW  
D



<small>PROPRIETARY NOTICE</small> <small>THIS DRAWING CONTAINS CONFIDENTIAL AND TRADE SECRET INFORMATION. IS THE PROPERTY OF INGERSOLL-RAND CO. AND IS GIVEN TO THE RECEIVER IN CONFIDENCE. THE RECEIVER BY ACCEPTANCE AND RETENTION OF THIS DRAWING ACCEPTS THE DRAWING IN CONFIDENCE AND AGREES THAT, EXCEPT AS AUTHORIZED IN WRITING BY INGERSOLL-RAND CO., IT WILL (1) NOT USE THE DRAWING OR ANY COPY THEREOF OR THE CONFIDENTIAL OR TRADE SECRET INFORMATION THEREIN; (2) NOT COPY THE DRAWING; (3) NOT DISCLOSE TO OTHERS EITHER THE DRAWING OR THE CONFIDENTIAL OR TRADE SECRET INFORMATION THEREIN; AND (4) UPON COMPLETION OF THE NEED TO RETAIN THE DRAWING, OR UPON DEMAND, RETURN THE DRAWING, ALL COPIES THEREOF, AND ALL MATERIAL COPIED THEREFROM.</small>		<small>NAME</small> <b>GENERAL ARRANGEMENT DRAWING, AIR COOLED (RS45-75I)</b>	
<small>SIZE</small> <b>A1</b>	<small>DWG NO.</small> <b>47613761001</b>	<small>REVISION</small> <b>C</b>	
<small>SCALE</small> 0.10	<small>NOMENCLATURE</small>	<small>SHEET</small> 6 OF 9	

# GENERAL ARRANGEMENT WITH OPTIONAL HIGH DUST PRE-FILTER - NO DRYER (OPTION IS NOT AVAILABLE FOR VSD UNITS)

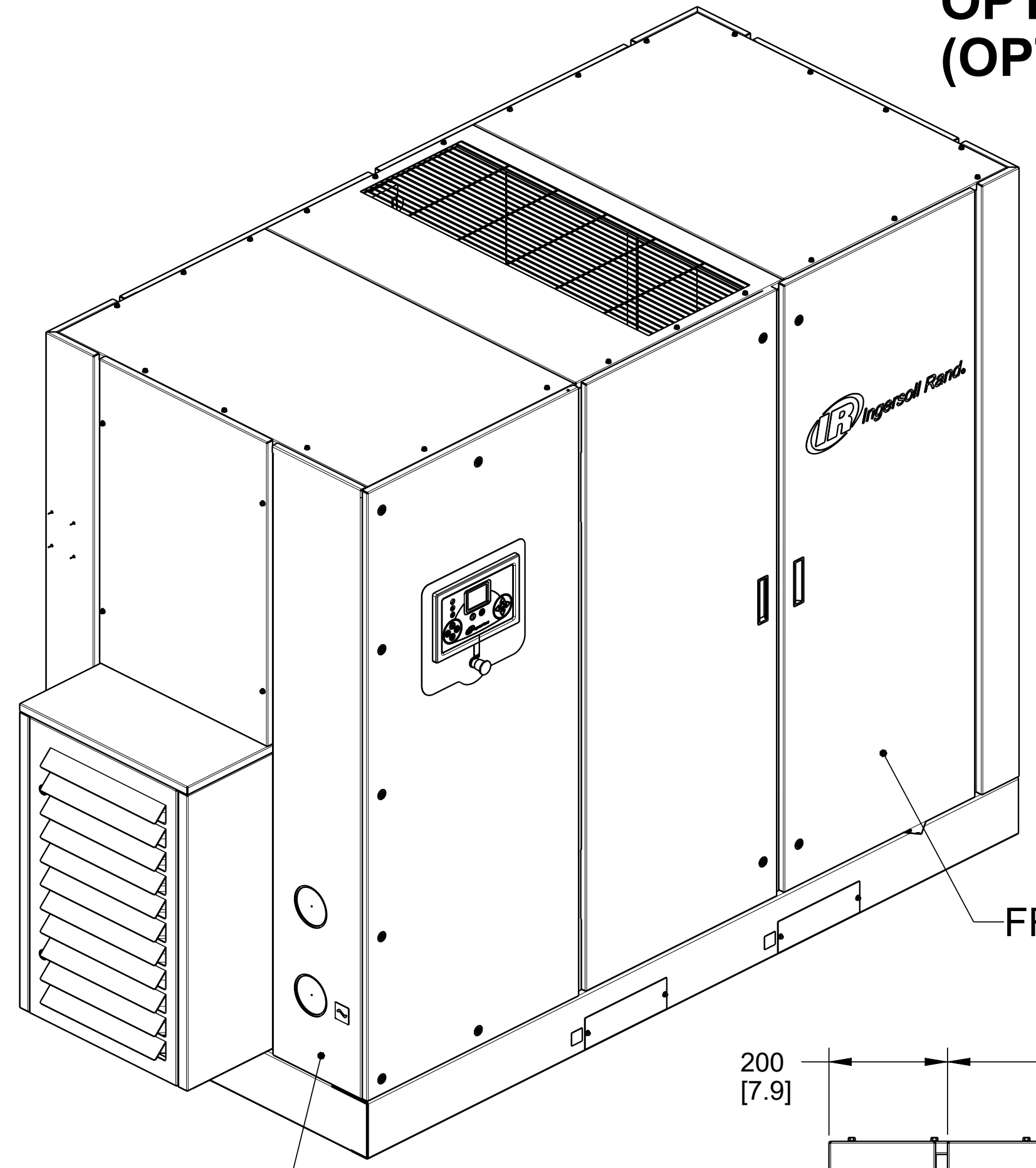

FRONT

LEFT END

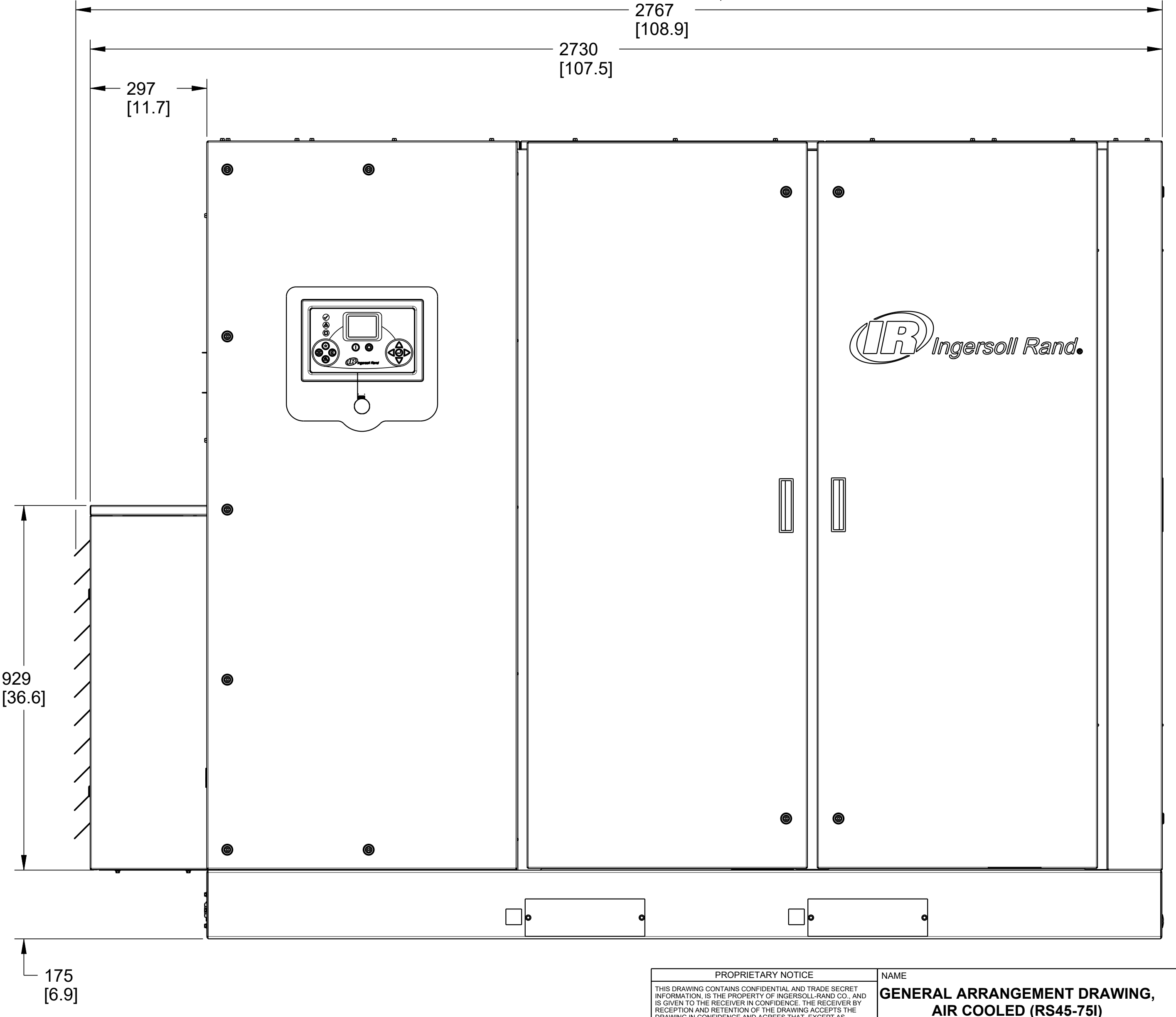
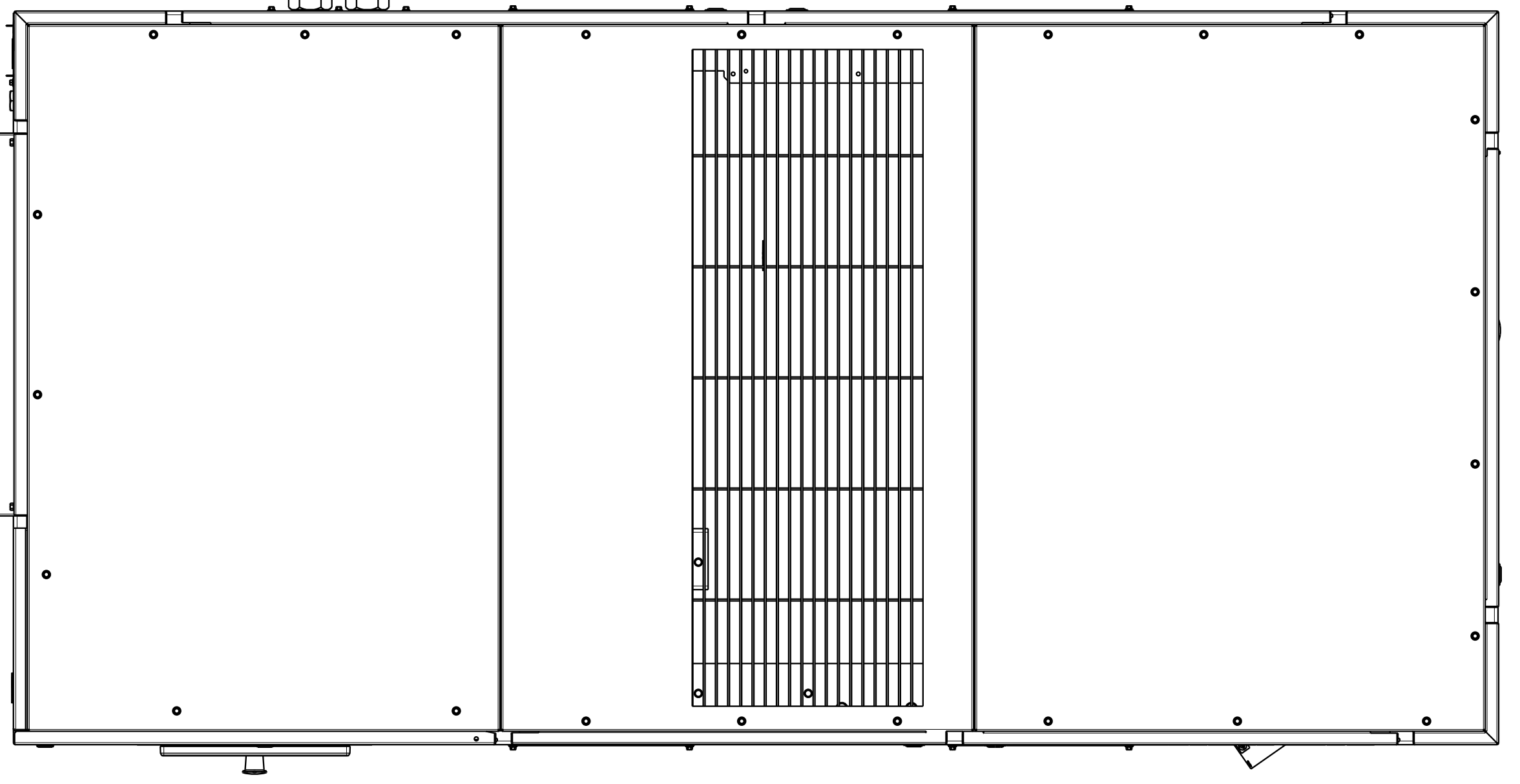
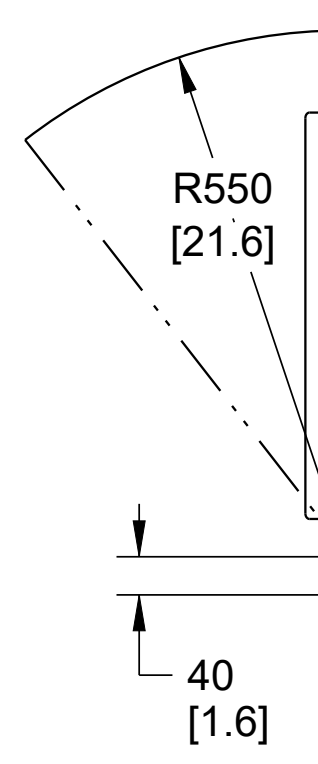
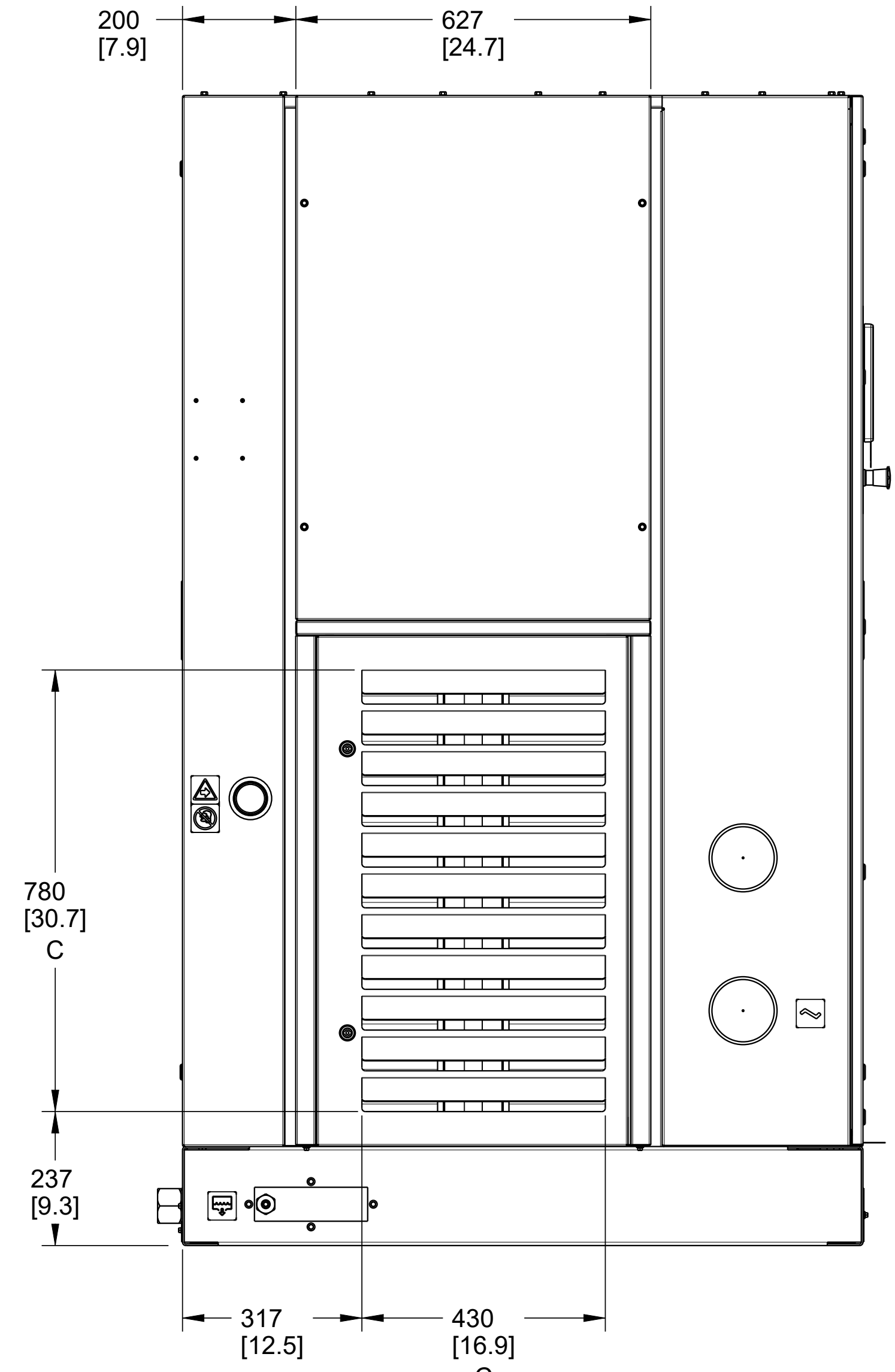

<small>PROPRIETARY NOTICE</small> <small>THIS DRAWING CONTAINS CONFIDENTIAL AND TRADE SECRET INFORMATION. IT IS THE PROPERTY OF INGERSOLL RAND CO. AND IS GIVEN TO THE RECEIVER IN CONFIDENCE. THE RECEIVER BY ACCEPTANCE AND RETENTION OF THE DRAWING ACCEPTS THE DRAWING IN CONFIDENCE AND AGREES THAT, EXCEPT AS AUTHORIZED IN WRITING BY INGERSOLL RAND CO., IT WILL (1) NOT USE THE DRAWING OR ANY COPY THEREOF OR THE CONFIDENTIAL OR TRADE SECRET INFORMATION THEREIN, (2) NOT COPY THE DRAWING, (3) NOT DISCLOSE TO OTHERS EITHER THE DRAWING OR THE CONFIDENTIAL OR TRADE SECRET INFORMATION THEREIN, AND (4) UPON COMPLETION OF THE NEED TO RETAIN THE DRAWING OR UPON DEMAND, RETURN THE DRAWING, ALL COPIES THEREOF, AND ALL MATERIAL COPIED THEREFROM.</small>		<small>NAME</small> <b>GENERAL ARRANGEMENT DRAWING, AIR COOLED (RS45-75I)</b>	
<small>SIZE</small> <b>A1</b>	<small>DWG NO.</small> <b>47613761001</b>	<small>REVISION</small> <b>C</b>	
<small>SCALE</small> 0.13	<small>NOMENCLATURE</small>	<small>SHEET</small> 7 of 9	

# GENERAL ARRANGEMENT WITH OPTIONAL HIGH DUST PRE-FILTER - WITH DRYER (OPTION IS NOT AVAILABLE FOR VSD UNITS)

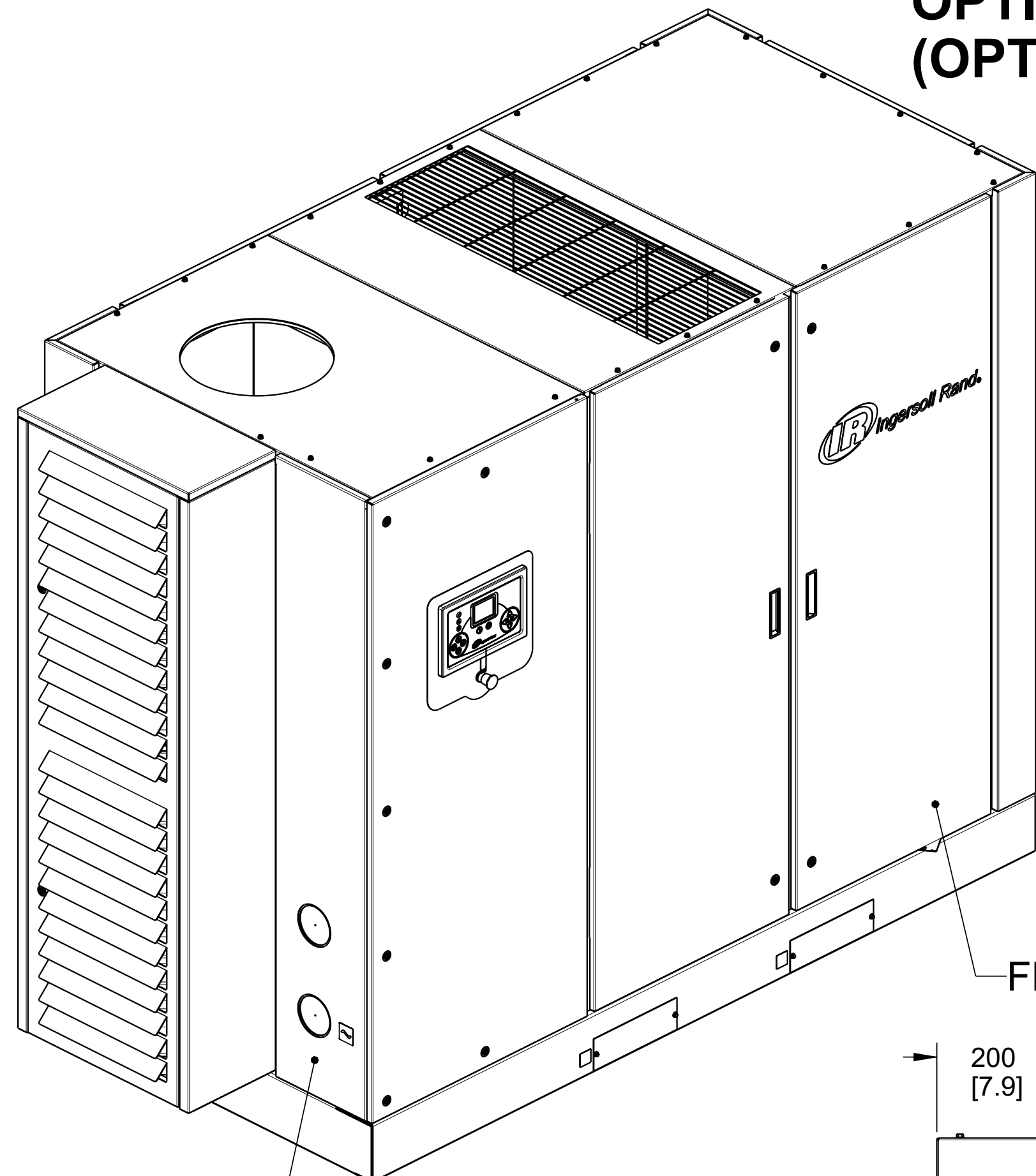

FRONT

LEFT END

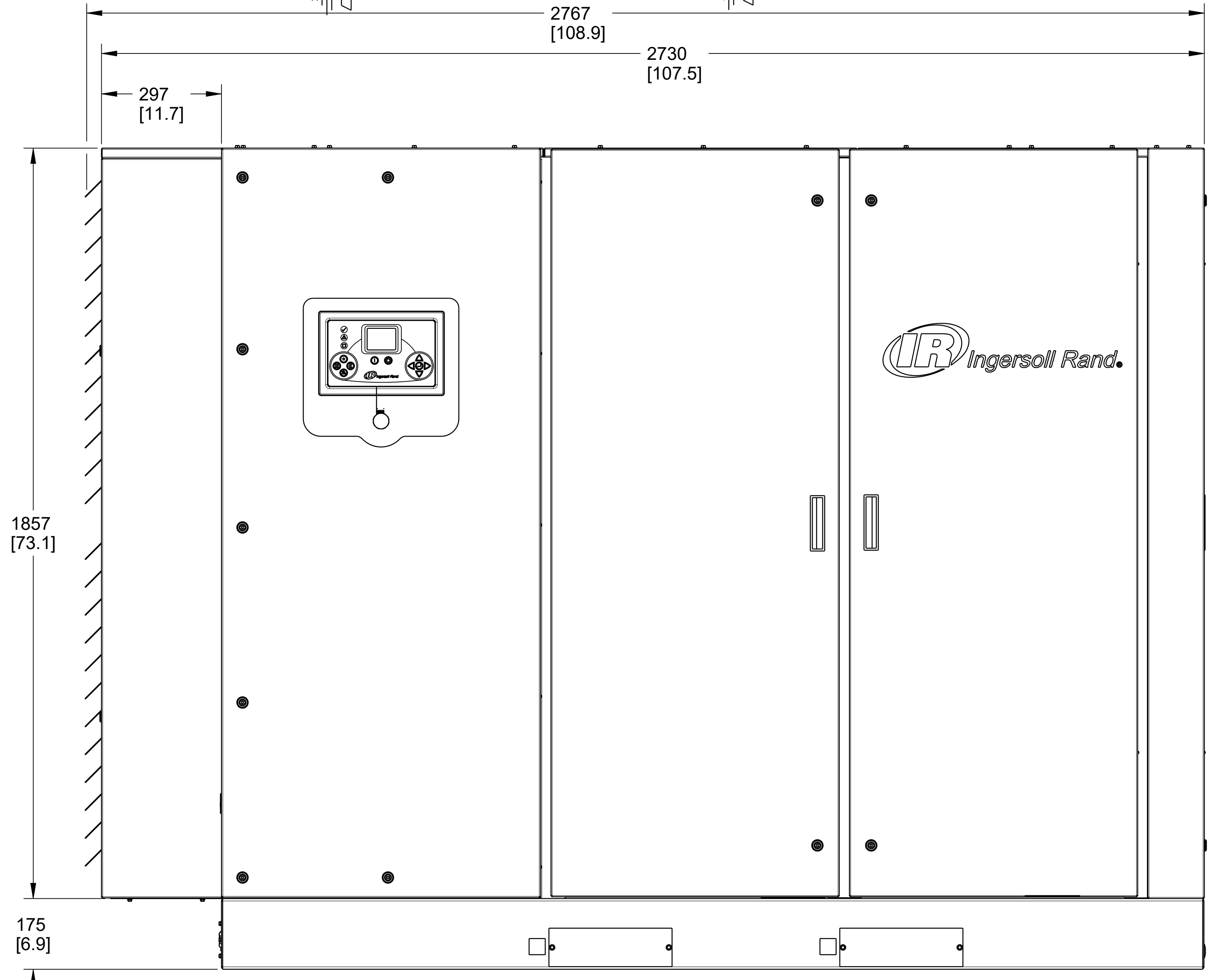
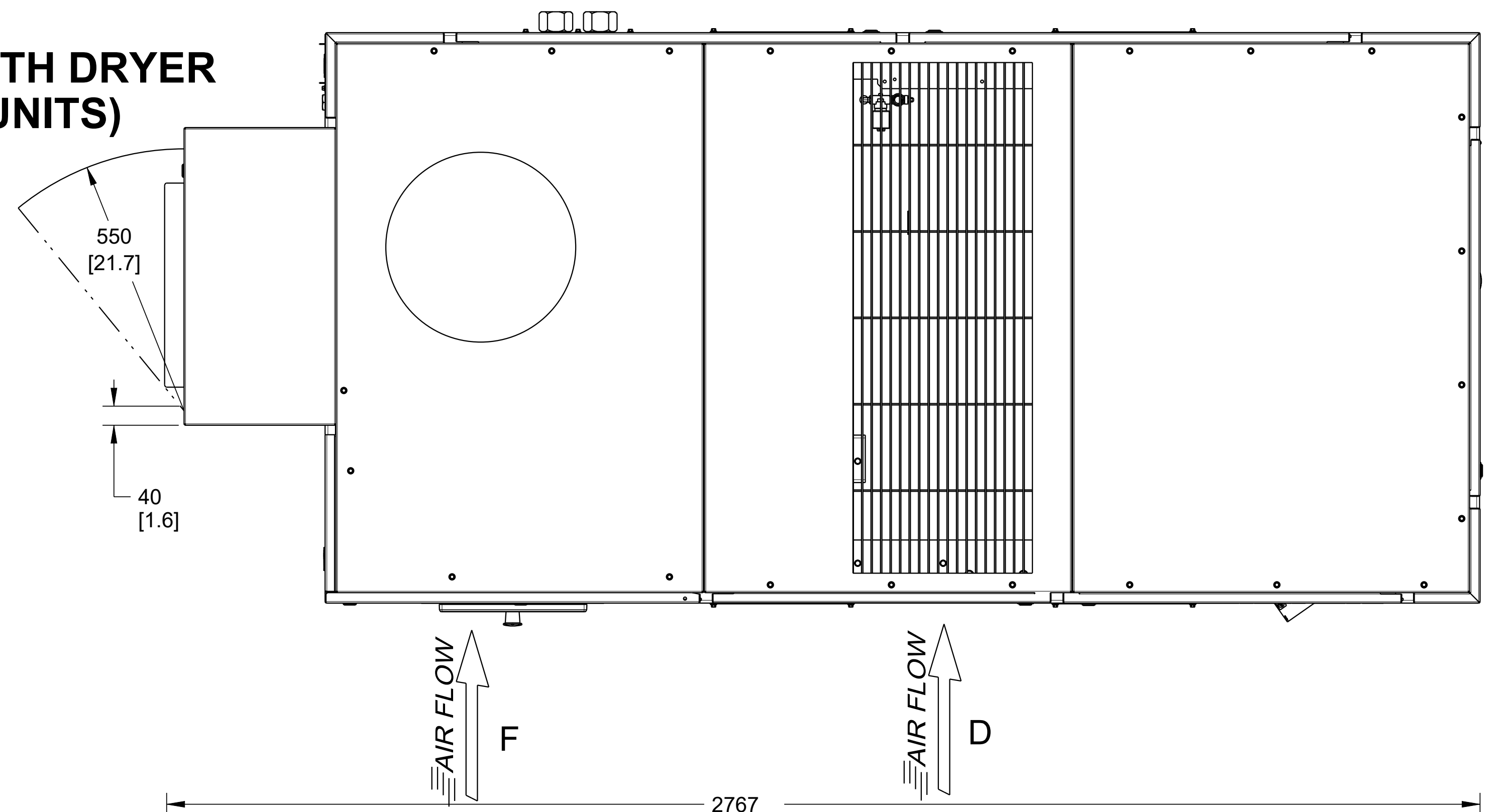
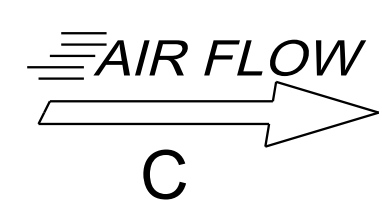
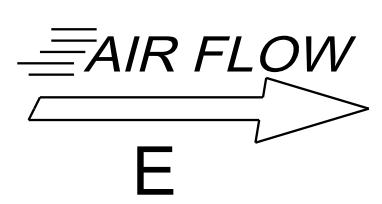
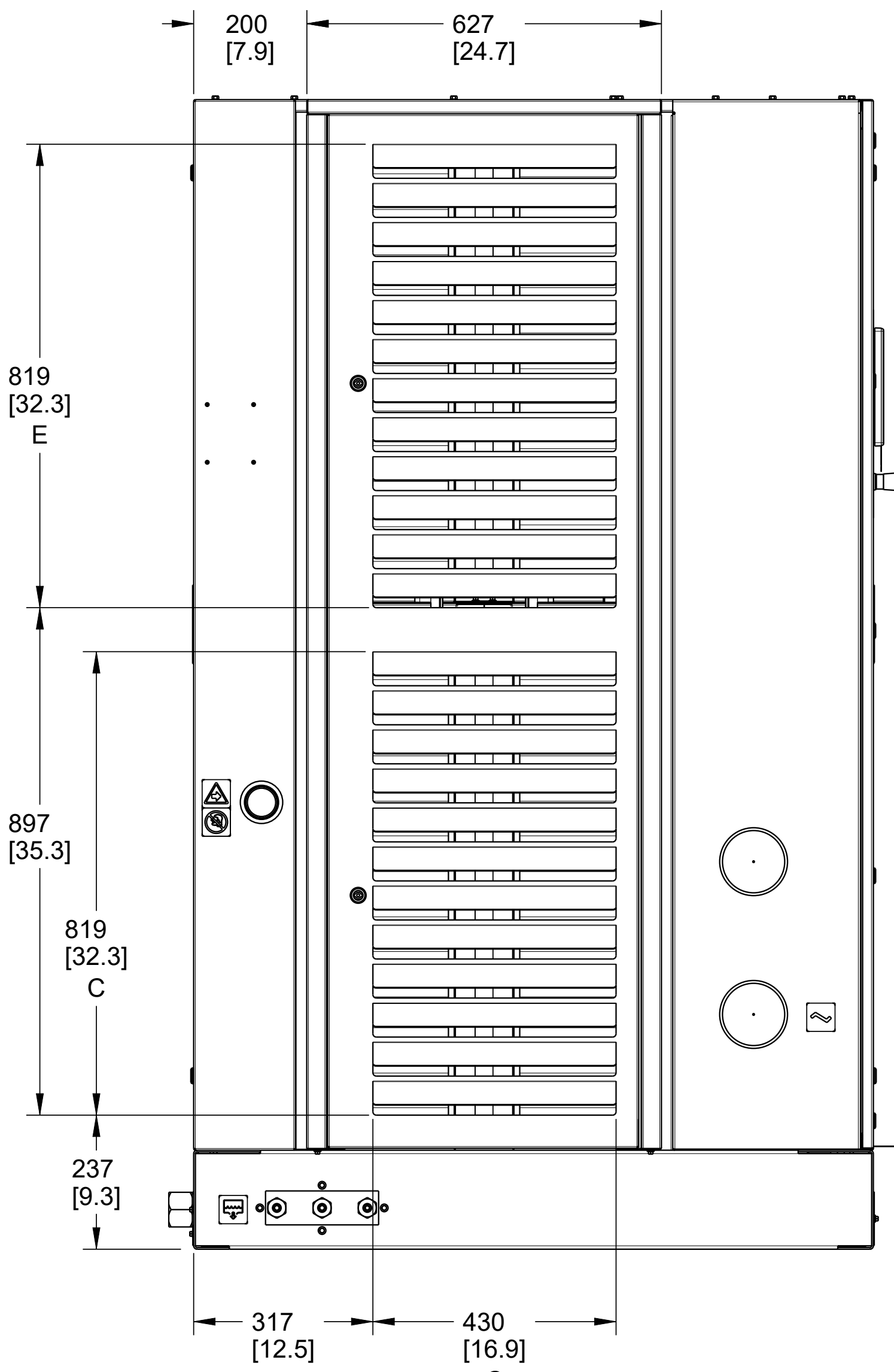

<small>PROPRIETARY NOTICE</small> <small>THIS DRAWING CONTAINS CONFIDENTIAL AND TRADE SECRET INFORMATION. IT IS THE PROPERTY OF INGERSOLL RAND CO. AND IS GIVEN TO THE RECEIVER IN CONFIDENCE. THE RECEIVER BY RECEIPT AND RETENTION OF THIS DRAWING ACCEPTS THE DRAWING IN CONFIDENCE AND AGREES THAT, EXCEPT AS AUTHORIZED IN WRITING BY INGERSOLL RAND CO., IT WILL (1) NOT USE THE DRAWING OR ANY COPY THEREOF OR THE CONFIDENTIAL OR TRADE SECRET INFORMATION THEREIN; (2) NOT COPY THE DRAWING; (3) NOT DISCLOSE TO OTHERS EITHER THE DRAWING OR THE CONFIDENTIAL OR TRADE SECRET INFORMATION THEREIN; AND (4) UPON COMPLETION OF THE NEED TO RETAIN THE DRAWING OR UPON DEMAND, RETURN THE DRAWING, ALL COPIES THEREOF, AND ALL MATERIAL COPIED THEREFROM.</small>		<small>NAME</small> <b>GENERAL ARRANGEMENT DRAWING, AIR COOLED (RS45-75I)</b>	
<small>SIZE</small> <b>A1</b>	<small>DWG NO.</small> <b>47613761001</b>	<small>REVISION</small> <b>C</b>	
<small>SCALE</small> 0.13	<small>NOMENCLATURE</small>	<small>SHEET</small> 8 of 9	



# GENERAL ARRANGEMENT WITH OPTIONAL CONTAINMENT BASE

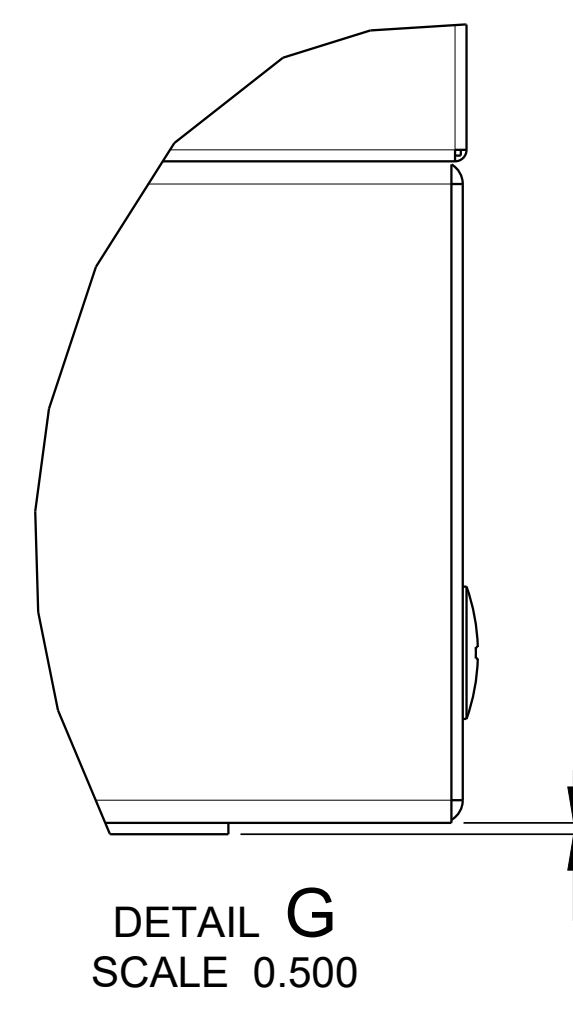
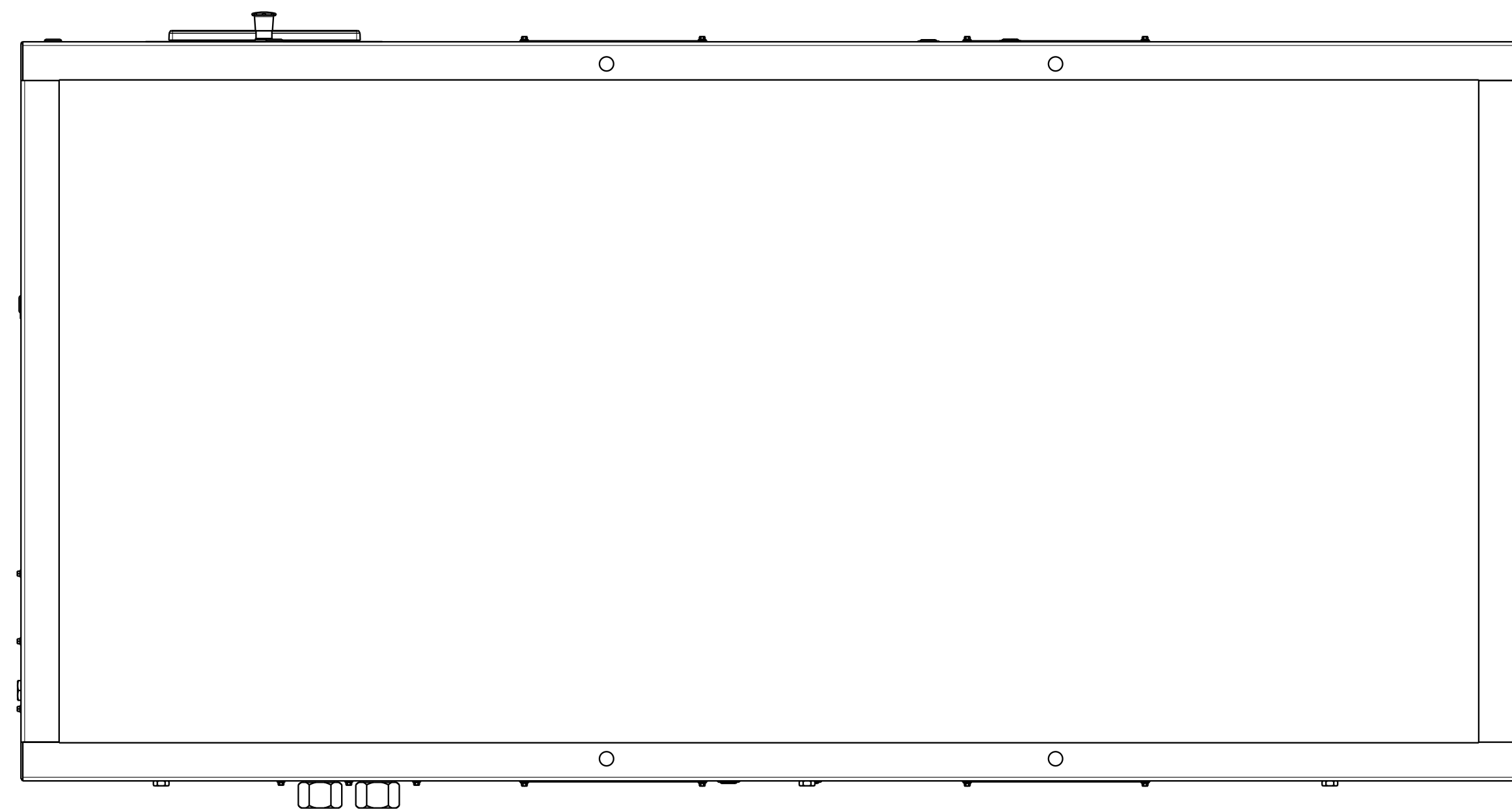
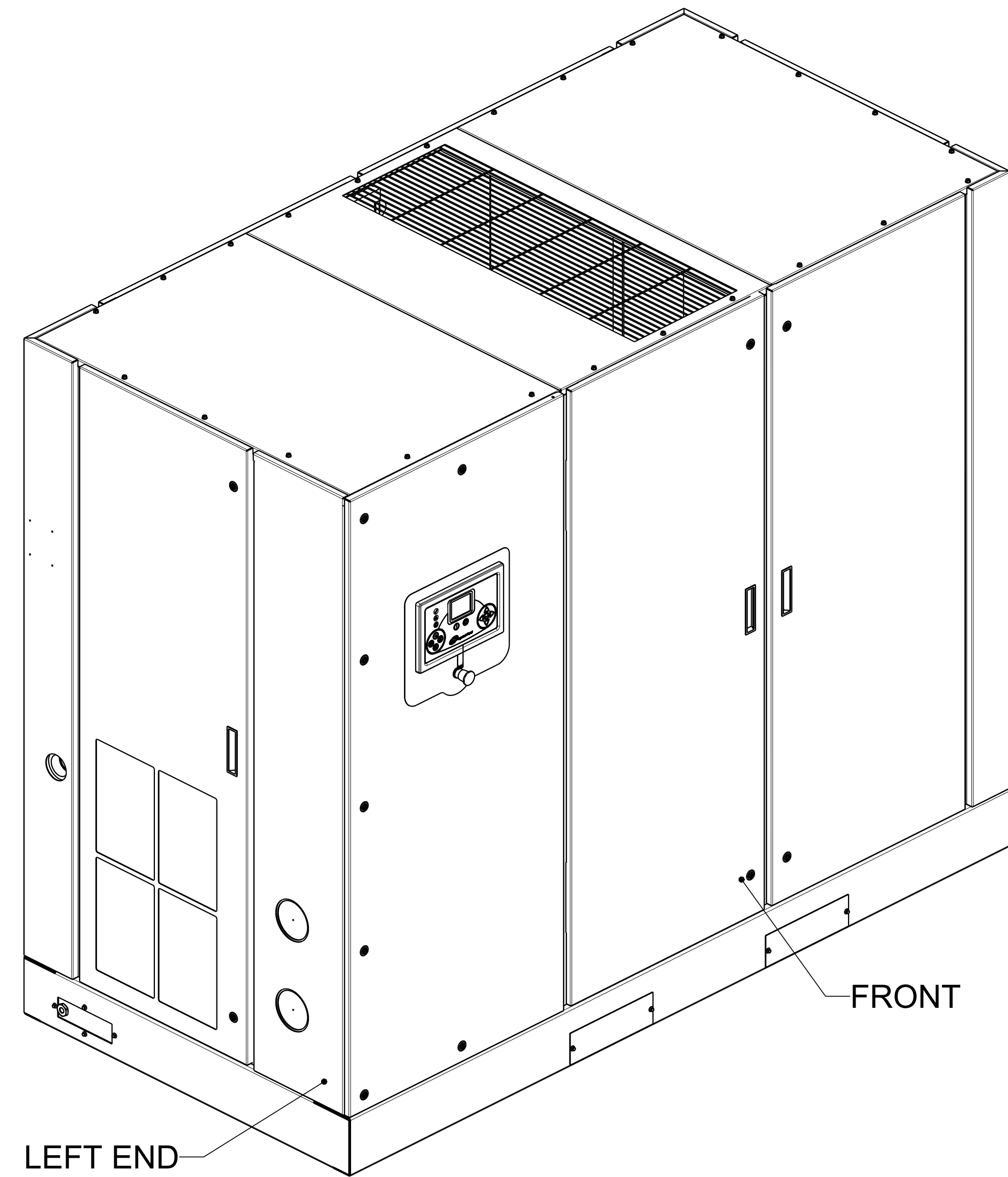
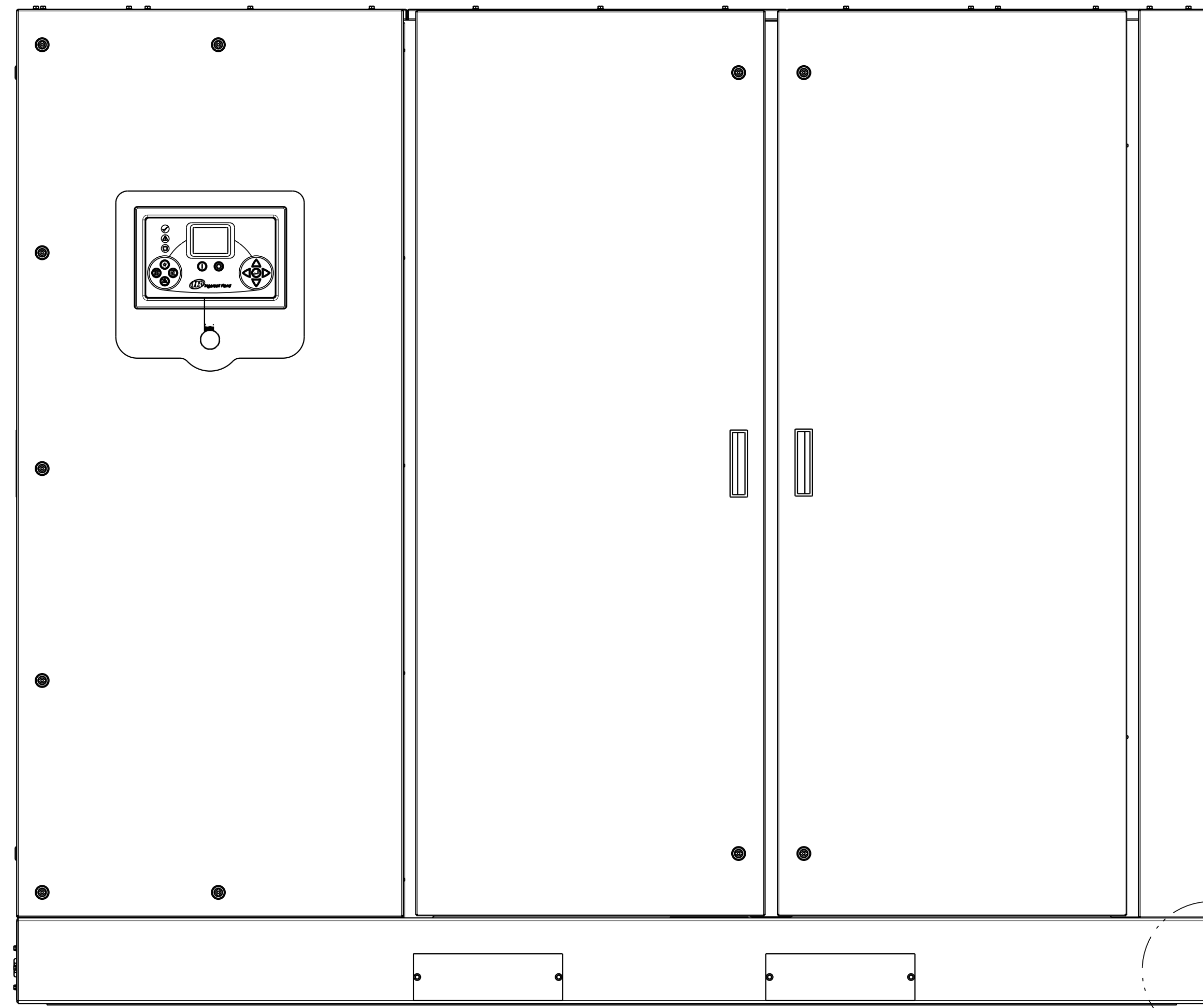

DETAIL G  
SCALE 0.500

3  
[0.1]  
(THIS VALUE NEEDS TO BE ADDED TO ALL HEIGHT DIMENSIONS WHEN THIS OPTION IS PURCHASED)

<small>PROPRIETARY NOTICE</small>		<small>NAME</small>	
<small>THIS DRAWING CONTAINS CONFIDENTIAL AND TRADE SECRET INFORMATION. IS THE PROPERTY OF INGERSOLL-RAND CO. AND IS GIVEN TO THE RECEIVER IN CONFIDENCE. THE RECEIVER BY RECEIPT AND RETENTION OF THE DRAWING ACCEPTS THE DRAWING IN CONFIDENCE AND AGREES THAT, EXCEPT AS AUTHORIZED IN WRITING BY INGERSOLL-RAND CO. IT WILL (1) NOT USE THE DRAWING OR ANY COPY THEREOF OR THE CONFIDENTIAL OR TRADE SECRET INFORMATION THEREIN; (2) NOT COPY THE DRAWING; (3) NOT DISCLOSE TO OTHERS EITHER THE DRAWING OR THE CONFIDENTIAL OR TRADE SECRET INFORMATION THEREIN; AND (4) UPON COMPLETION OF THE NEED TO RETAIN THE DRAWING OR UPON DEMAND, RETURN THE DRAWING, ALL COPIES THEREOF, AND ALL MATERIAL COPIED THEREFROM.</small>		<small>GENERAL ARRANGEMENT DRAWING, AIR COOLED (RS45-75I)</small>	
<b>A1</b>	<small>DWG NO.</small>	<b>47613761001</b>	<small>REVISION</small>
<b>C</b>	<small>PART NO.</small>		<b>C</b>
<small>SCALE</small>	<small>NOMENCLATURE</small>		<small>SHEET</small>
0.13			9 of 9