

Coalescing and Particulate Oxygen Filters

Models | O20006 to O21500

Flow Rates 5.7 SCFM (9.5 Nm³/hr) to 1425.0 SCFM (2422.5 Nm³/hr)

Walker Filtration's New Oxygen Filters are cleaned for oxygen service in accordance with ASTM G93/G93M, protecting the integrity and safety of your gas generation system and delivering reliable filtration in line with the purity standards required for your end application.

Our Oxygen Filters provide high quality inlet air prior to entering an oxygen generator, as well as the required filtration after the generation process, to ensure the gas meets purity standards and does not carry particulate or other contaminants.

Available in both Coalescing and Particulate (dust) filtration grades from 5 – 0.01 micron, our Oxygen Filters combine market leading Alpha filtration technology with a specialized manufacturing process to ensure energy efficiency and superior filtration performance.

Walker Filtration's Oxygen Filters are manufactured on a dedicated line with strict cleaning methods to ensure the removal of all unwanted contaminants.



Cleaned in accordance with ASTM G93/G93M

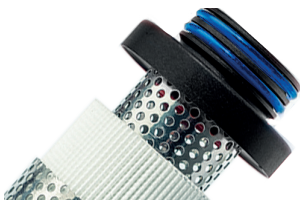

Unique Filtration Technology
Oxygen rated construction with Alpha deep pleated media delivers market leading filtration performance



Contaminant Free Manufacturing
All components and materials are thoroughly cleaned and certified for use in oxygen rich environments



Modular Filter
Low cost connecting kits and filter head design enables easy close coupling assembly

- **Market Leading Performance** Custom engineered filtration media delivers optimum performance in line with air quality standard ISO 8573-1: 2010, and significantly reduced pressure loss of <1.8 psi (125 mbar) across X1 1.0 and XA 0.01 micron grades
- **Simplified Serviceability** Externally accessible drain, profiled bowl design and unique push fit elements ensure quick and reliable maintenance
- **Flow-Optimized Design** Advanced filter head design for optimized flow performance
- **Corrosion Protection** Internal and external electrophoretic paint finish followed by a tough exterior polyester powder coating
- **Suitable for Oxygen Service** Oxygen Filters are specially designed, cleaned and packaged, to ensure all combustible components are removed from the filter to prevent risk of ignition
- **Product Safety in Mind** Guaranteed safe housing closure with rotational safety stop



Medical



Food & Beverage



Steel Production

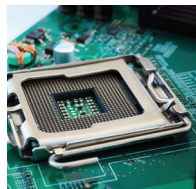

Electronics



Automotive

For further information please visit www.walkerfiltration.com

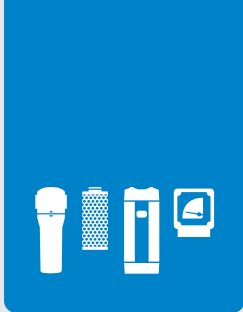

Technical Specification

Coalescing and Particulate Filter Model	Pipe size inches	Inlet flow rate*		Dimensions inches (mm)				Weight		Element model
		SCFM	Nm ³ /hr	A	B	C	D	lbs	Kg	
O20006 (grade)	1/8	5.7	9.5	1.97 (50)	0.67 (17)	6.18 (157)	2.36 (60)	0.6	0.3	EO20306 (grade)
O20015 (grade)	1/4	14.3	23.8	1.97 (50)	0.67 (17)	6.18 (157)	2.36 (60)	0.6	0.3	EO20306 (grade)
O20025 (grade)	1/4	23.8	39.9	2.76 (70)	0.91 (23)	9.09 (231)	2.76 (70)	1.3	0.6	EO20408 (grade)
O20032 (grade)	3/8	30.4	51.3	2.76 (70)	0.91 (23)	9.09 (231)	2.76 (70)	1.3	0.6	EO20408 (grade)
O20050 (grade)	1/2	47.5	80.8	2.76 (70)	0.91 (23)	9.09 (231)	2.76 (70)	1.3	0.6	EO20412 (grade)
O20070 (grade)	1/2	66.5	113.1	5.00 (127)	1.26 (32)	11.22 (285)	3.15 (80)	3.7	1.7	EO20612 (grade)
O20085 (grade)	3/4	80.8	136.8	5.00 (127)	1.26 (32)	11.22 (285)	3.15 (80)	3.7	1.7	EO20612 (grade)
O20105 (grade)	1	99.8	169.1	5.00 (127)	1.26 (32)	11.22 (285)	3.15 (80)	3.7	1.7	EO20612 (grade)
O20125 (grade)	3/4	118.8	201.4	5.00 (127)	1.26 (32)	14.57 (370)	3.15 (80)	4.4	2.0	EO20621 (grade)
O20175 (grade)	1	166.3	282.2	5.00 (127)	1.26 (32)	14.57 (370)	3.15 (80)	4.4	2.0	EO20621 (grade)
O20280 (grade)	1 1/4	266.0	452.2	5.51 (140)	1.61 (41)	18.74 (476)	3.35 (85)	6.6	3.0	EO20731 (grade)
O20320 (grade)	1 1/2	304.0	516.8	5.51 (140)	1.61 (41)	18.74 (476)	3.35 (85)	6.6	3.0	EO20731 (grade)
O20400 (grade)	1 1/2	380.0	646.0	6.69 (170)	2.08 (53)	20.00 (508)	3.94 (100)	10.8	4.9	EO20831 (grade)
O20450 (grade)	2	427.5	726.8	6.69 (170)	2.08 (53)	20.00 (508)	3.94 (100)	10.8	4.9	EO20831 (grade)
O20700 (grade)	2	665.0	1129.6	6.69 (170)	2.08 (53)	27.87 (708)	3.94 (100)	12.1	5.5	EO20850 (grade)
O20850 (grade)	2 1/2	807.5	1371.8	8.66 (220)	2.75 (70)	28.97 (736)	3.94 (100)	23.1	10.5	EO21140 (grade)
O20900 (grade)	3	855.0	1452.6	8.66 (220)	2.75 (70)	28.97 (736)	3.94 (100)	23.1	10.5	EO21140 (grade)
O21250 (grade)	3	1187.5	2018.8	8.66 (220)	2.75 (70)	33.74 (857)	3.94 (100)	25.4	11.5	EO21160 (grade)
O21500 (grade)	3	1425.0	2422.5	8.66 (220)	2.75 (70)	39.56 (1005)	3.94 (100)	27.6	12.5	EO21175 (grade)

* Rated flow at 100 psig (7 barg), reference conditions 14.7 psi(a) (1.014 bar(a)) 68°F (20°C), calculated using 0.95 Gas Density Factor based on 93% oxygen saturation

Grade	X5/RX5		X1/RX1		XA/RXA	
Particle removal	5 micron		1 micron		0.01 micron	
Max particle size class**	4		3		1	
Max oil content**	4		3		1	
Max oil carryover at 68°F (20°C) coalescing	5 ppm	5 mg/m ³	0.3 ppm	0.3 mg/m ³	0.01 ppm	0.01 mg/m ³
Max oil carryover at 68°F (20°C) particulate	N/A	N/A	N/A	N/A	N/A	N/A
Pressure loss - clean & dry coalescing	0.6 psi	40 mbar	0.8 psi	55 mbar	1.2 psi	85 mbar
Pressure loss - clean & dry particulate	0.6 psi	40 mbar	1.1 psi	75 mbar	1.5 psi	100 mbar
Pressure loss - saturated coalescing	1.1 psi	75 mbar	1.8 psi	125 mbar	1.8 psi	125 mbar
Pressure loss - saturated particulate	N/A	N/A	N/A	N/A	N/A	N/A
Pressure loss - element change	12 mths	8000 hrs	12 mths	8000 hrs	12 mths	8000 hrs
Max temperature	248°F	120°C	248°F	120°C	248°F	120°C
Max working pressure	300 psig	20.7 barg	300 psig	20.7 barg	300 psig	20.7 barg
Max autoclave temperature	N/A					
Element end cap color	Black					

** to ISO 8573-1: 2010

Pressure correction factors	for maximum flow rate, multiply model flow rate by the correction factor corresponding to the minimum operating pressure									
Operating pressure psig (barg)	58 (4)	72 (5)	87 (6)	100 (7)	115 (8)	145 (10)	174 (12)	203 (14)	232 (16)	300 (20.7)
100 psig - correction factor	0.76	0.84	0.92	1.00	1.07	1.19	1.31	1.41	1.51	1.73

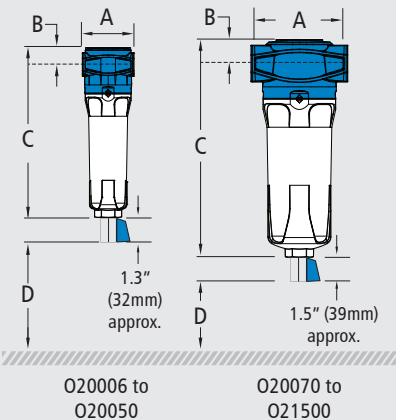

Technical Notes

- Direction of flow is inside to out through the filter element for coalescing grades (X5, X1 and XA), and outside to in for particulate grades (RX5, RX1 and RXA).
- All Oxygen Filters are fitted as standard with Manual Drain Valves, VMDV25 on models O20006 to O20050, VMDVE25B on models O20070 to O20700 and VMDVE25M on models O20850 to O21500. Standard filters can operate at 300 psig (20.7 barg) range at 248°F (120°C).
- Alpha Oxygen Filters are manufactured from cast aluminum alloy and are PED 2014/68/EU compliant for group 1 and group 2 gases.
- Threaded connections are NPT to ANSI/ASME B1.20 as standard. RP (BSP Parallel) to ISO 7-1 and RC (BSP Taper) to ISO 7-1 are also available up on request.
- Filters are suitable for use with mineral and synthetic oils plus oil-free compressed air applications.
- Filter elements should be changed every 12 months / 8000 hours (whichever comes first).
- Walker Filtration genuine spare and aftermarket parts must be used, failure to do so will void product warranty. Walker Filtration shall not be held liable for damages suffered by the customer if Walker Filtration genuine oxygen rated spare and aftermarket parts are not used.
- All Walker Filtration Alpha Oxygen Filters are produced from high quality, non-toxic, naturally inert raw materials and constituents, in accordance with FDA requirements for food contact as per Code of Federal Regulation (CFR), Title 21.
- Other filtration grades are available. Please contact sales for specific requests.

