

Republic offers the VRT series of dry-running rotary vane vacuum pumps and are ideally suited for oil-free applications. They are single stage, air-cooled and direct driven for continuous operation. The design is one of the most reliable and simplest vacuum pumps available. These rugged pumps are simple to install and easy to service and maintain. The smaller pumps come with a motor integrated, while the larger pumps are available with or without motor. These pumps have a displacement ranging from 5 to 177 CFM (10 to 300 m³/hr) and a maximum vacuum of 150 torr.

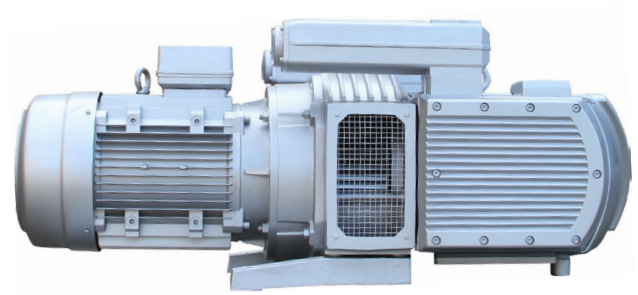

The VRT series is used in a variety of industries such as vacuum lifting, woodworking, environmental applications electronics, packaging, conveying, robotics, medical vacuum/central vacuum, and printing.

PERFORMANCE

Model	Displacement (CFM/m ³ /hr)		Ultimate Vacuum Max (In. Hg./Torr/mbar)	Noise Level (dB)		Weight (lb/kg)	Motor Output		Voltage 3 Phase (V)		Speed (rpm)	
	50 Hz	60 Hz		50 Hz	60 Hz		50 Hz	60 Hz	50 Hz	60 Hz	50 Hz	60 Hz
3250	147/250	177/300	23.6/150/200	81	81	688/312	5.5 kw	8.9 hp	230/400	208-230/460	960	1150

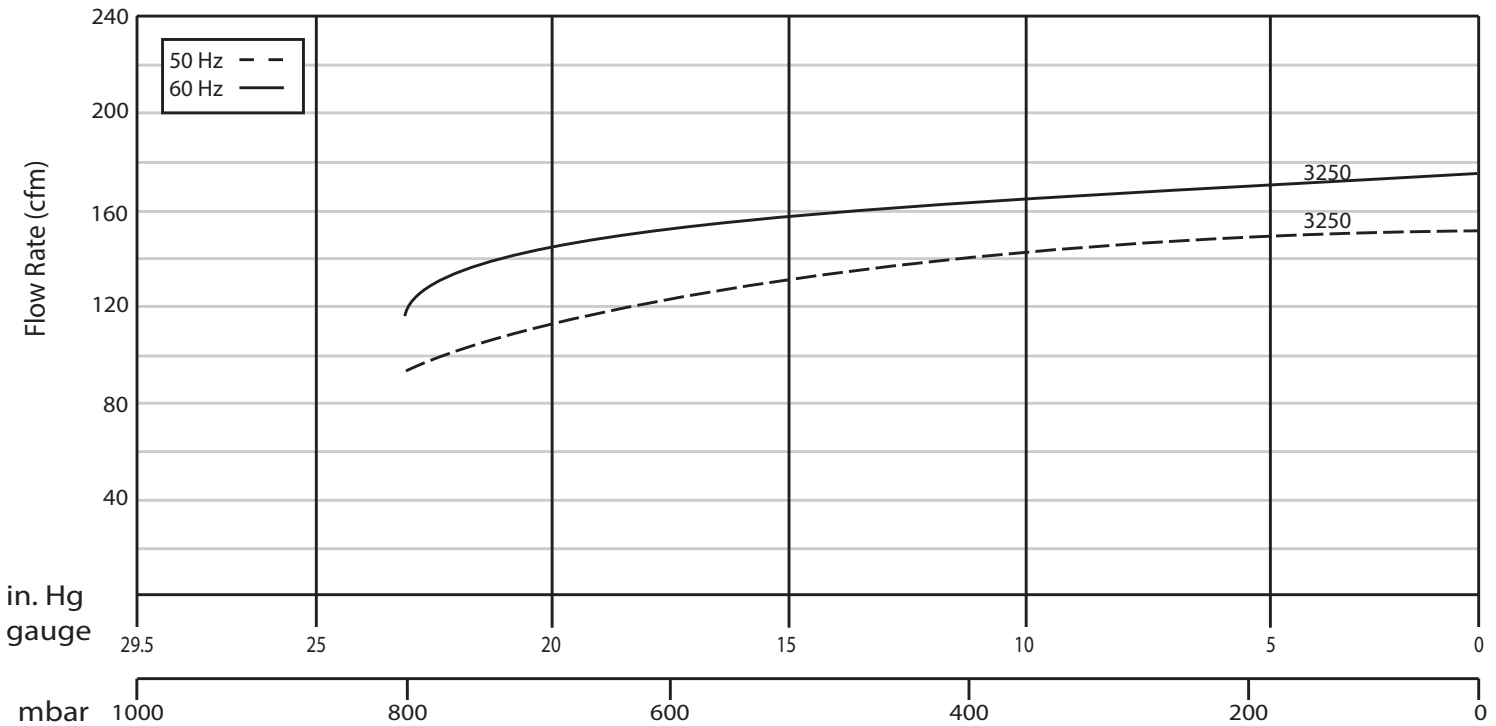

All measurements are ±10%

APPROXIMATE DIMENSIONS

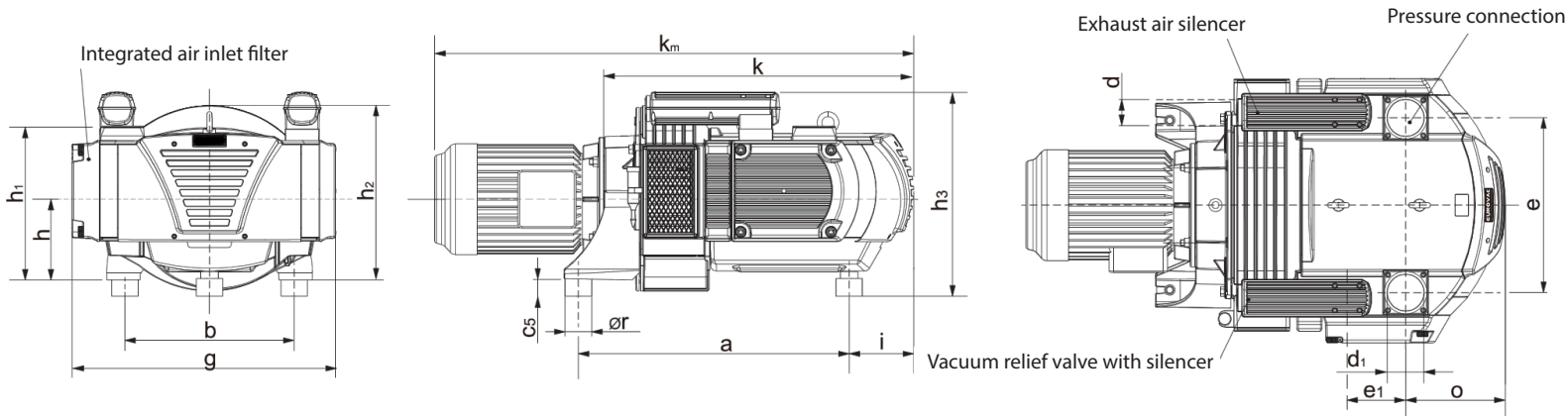

Model	Unit	a	b	c5	d	d1	e	e1	g	h	h1	h2	h3	i	k	km	o	r	s
3250	in	25.4	15	1.6	2.0	2.5	16.7	8.5	24.1	8.9	15.3	16.8	19.5	4.9	26.9	43	6.8	2.0	M10
	mm	645	380	40			423	216	612	225	389	426	494	125	684	1092	172		

Optional Accessories

- Inlet filter
- Inlet check valve
- Vacuum gauge
- Motor starter
- Control panel
- PLC