

Ed	Position	Description	Date	Intr./Appd.
00		DRAWING RELEASED	03/22	BW

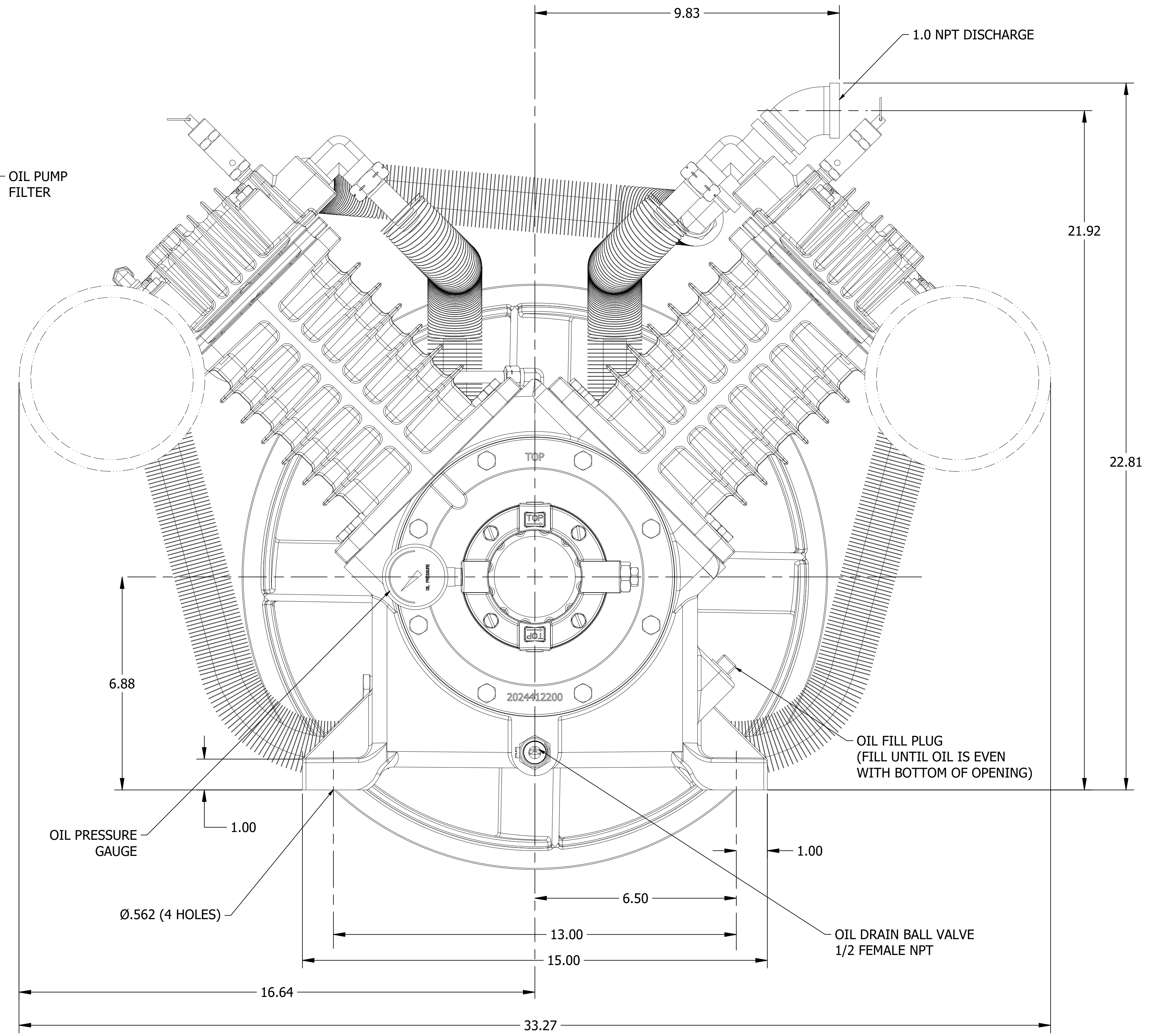
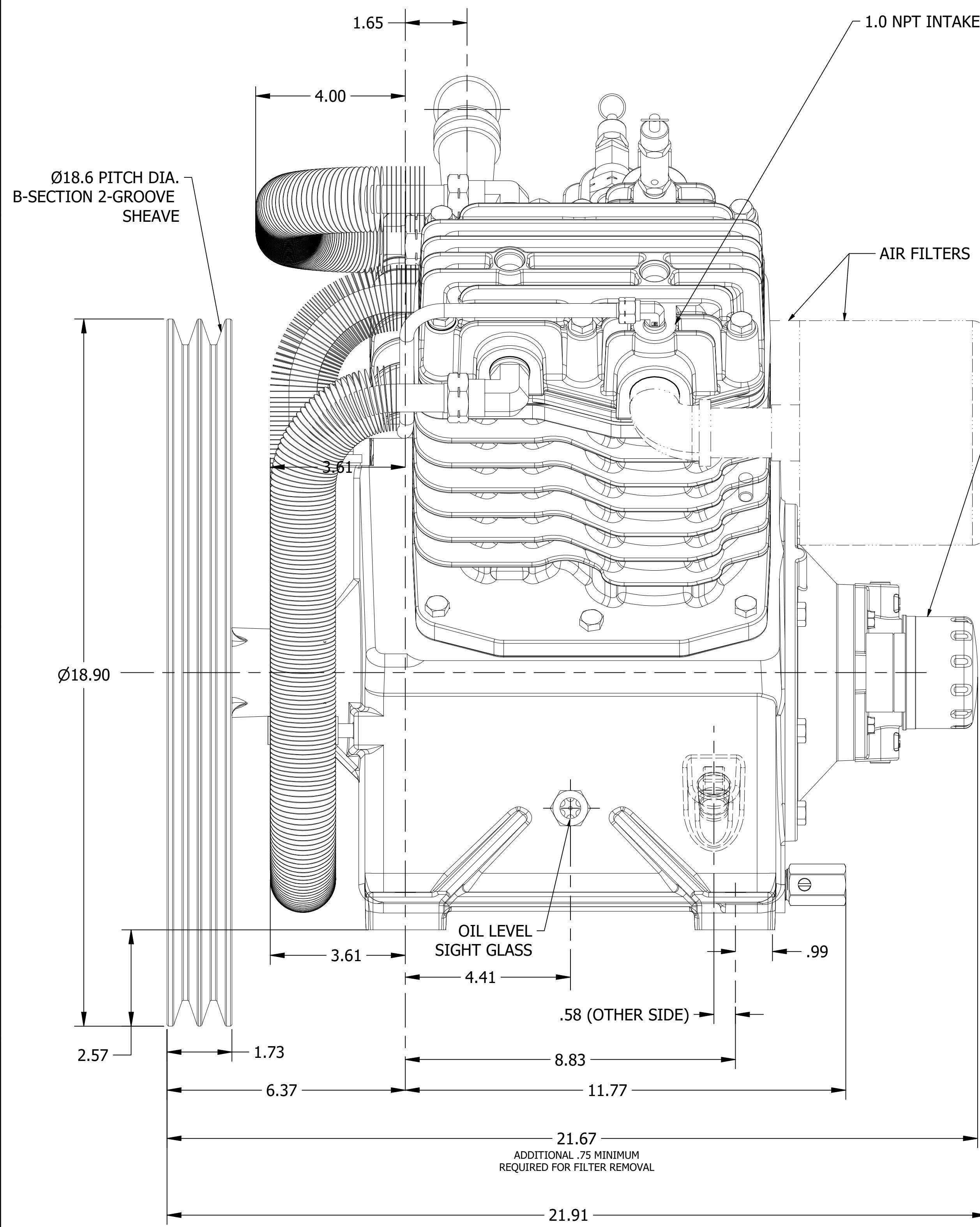

- NOTES
- 1) ALL DIMENSIONS GIVEN IN INCHES
  - 2) QP-2 BASIC IS PRESSURE LUBRICATED
  - 3) STANDARD WEIGHT (DRY): APPROX. 265 LBS
  - 4) SEE SHEET 2 FOR OPTIONAL HEAD UNLOADERS

Name: DWG, DIMENSIONAL, QP-2, BASIC		Confidentiality Class: 1102K Internal	
Material: Not Applicable		Drawing owner: UTY	
Finish: Not Applicable		Replaces:	
Scale: 1:2	Family:	Similar to:	Designation:
Drawn by: utywalker	Make From:	Replaces:	Sheet 1 / 2
Version Drwg:	Blank wt:	lb:	265
Des checked:	Prod checked:	Approved:	Date: 22/03/2022
Parent 3D model:	Ed. Version 3D:	2020040410	

All materials supplied are in compliance with the requirements of the List of Prohibited Substances.  
 CONFIDENTIAL: The information contained herein is the property of Quincy Compressor LLC and shall not be disclosed or made available to any other person or company.

Ed	Position	Description	Date	Intr./Appd.
00		DRAWING RELEASED	03/22	BW

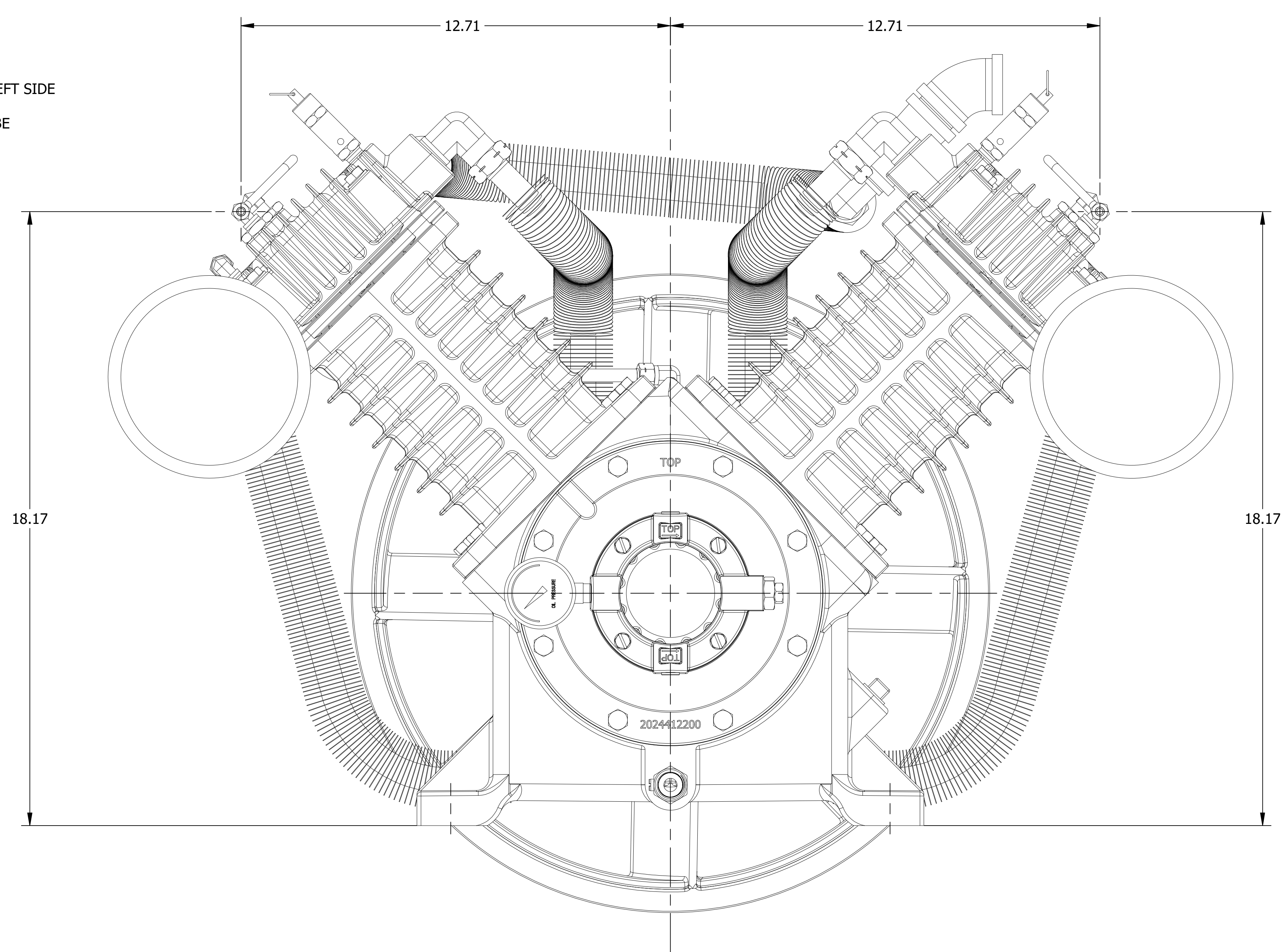
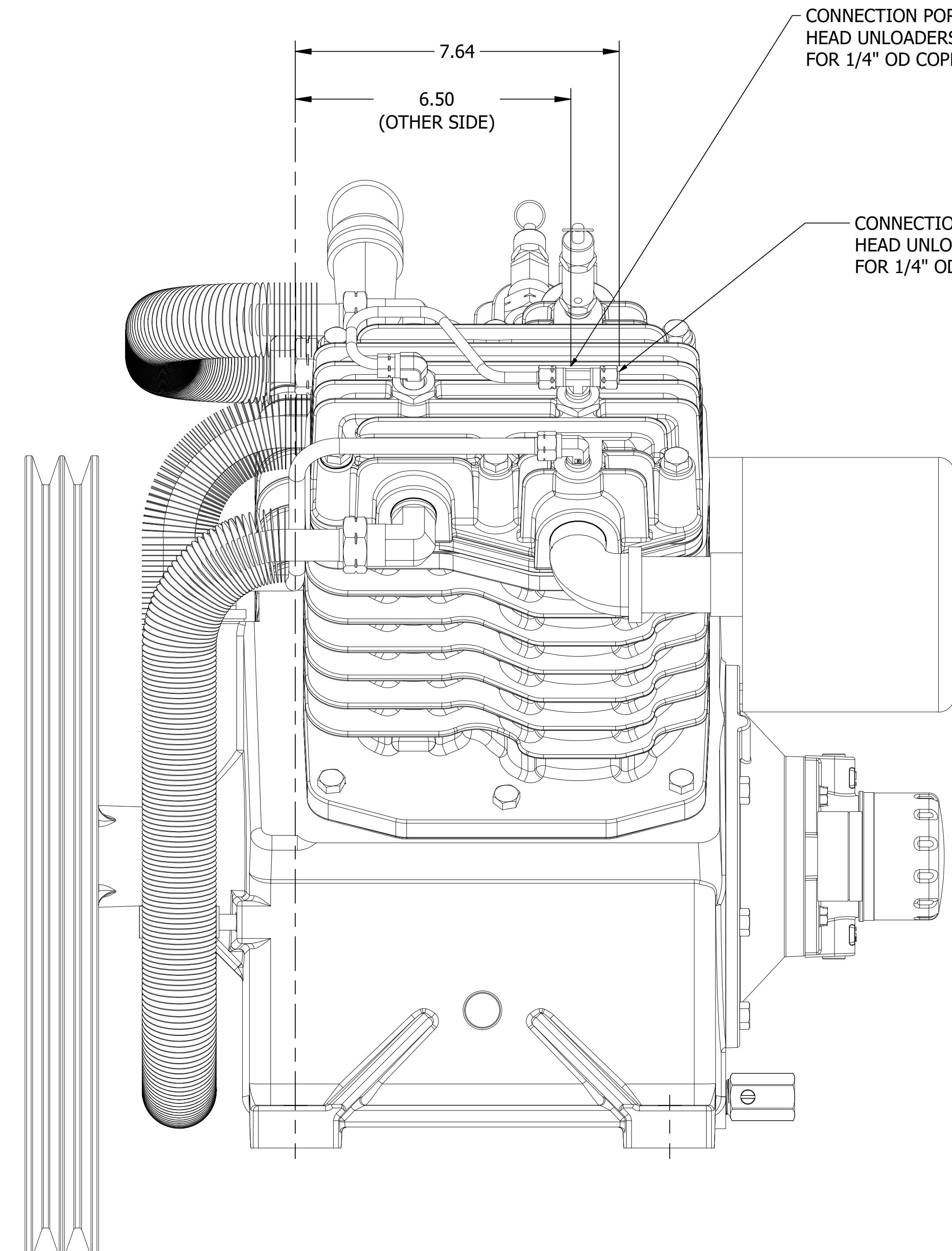

CONFIDENTIAL: This document is property of Quincy Compressor, LLC and shall not be used or reproduced without our permission. All rights reserved.

Name		DWG.DIMENSIONAL,QP-2,BASIC			Confidentiality Class acc. to 1102K Internal	
Material		Not Applicable			INV	
Finish		Not Applicable			Drawing owner UTY	
Scale		1:2	Family	D	Similar to	Replaces
Drawn by		utywalker	Make From			
Version Drwg			Blank wt	lb	Fini wt.	265 lb
STATUS		Des checked.	Prod checked.	Approved.	Date	22/03/2022
Parent 3D model		Ed . Version 3D	Approved Internal			2020040410
						Sheet 2 / 2