

 (704) 660-0334

Appropriate solutions for all your **compressed air needs**



OPERATOR MANUAL FOR OASC D COMPRESSORS (55) kW

www.ozenairtech.com

 **ozen**
AIR TECHNOLOGY

EXCLUSIVELY COMPRESSED AIR SOLUTIONS

TABLE OF CONTENTS

1. CHAPTER / SAFETY	1		
1.1 SAFETY SYMBOL AND GENERAL SAFETY MEASURES	1		
2. CHAPTER / INSTALLATION	5		
2.1 HANDLING AND INSTALLATION OF THE COMPRESSOR	5		
2.2 VENTILATION AND COOLING	9		
2.3 SERVICE AIR PIPES	11		
2.4 ELECTRICAL CONNECTION	11		
2.4.1 ELECTRIC DIAGRAMS	14		
2.5 INSTALLATION CONTROLS	15		
2.5.1 COUPLING COVER CONTROL	15		
2.5.2 OIL LEVEL CHECK	16		
2.5.3 MOTOR ROTATION DIRECTION CONTROL	18		
3. CHAPTER / THE SYSTEM OF COMPRESSOR	19		
3.1 INTRODUCTION / DEFINITION	19		
3.2 COMPONENTS	21		
3.2.1 MOTOR & AIR-END GROUP	21		
3.2.1.1 ELECTRIC MOTOR	22		
3.2.1.2 AIR INTAKE GROUP	22		
3.2.1.3 SEPARATOR GROUP	23		
3.2.1.3.1 SEPARATOR TANK	24		
3.2.1.3.2 SEPARATOR BLOCK	25		
3.2.1.3.3 SEPARATOR	26		
3.2.1.3.4 OIL FILTER	26		
3.2.1.4 AIR-END	26		
3.2.1.5 DIRECT COUPLED SYSTEM	26		
3.2.1.6 ELECTRIC MOTOR SUPPORT AND AIR END SUPPORT	27		
3.2.2 COOLING SYSTEM	27		
3.2.3 CONTROL PANEL	28		
3.2.4 ELECTRIC CABINET	30		
3.2.4.1 INVERTER	33		
3.2.5 COMPRESSOR CABINET	34		
4. CHAPTER / HOW IT OPERATES	35		
4.1 GETTING STARTED	35		
4.2 CONTROL PANEL	37		
4.2.1 MAESTRO 30 CONTROL PANEL DISPLAY	38		
4.2.2 MAESTRO 30 CODES AND DESCRIPTIONS OF ALARMS	40		
4.2.3 MAESTRO 30 MAINTENANCE CODES	46		
4.2.4 MAESTRO 30 DESCRIPTION OF STATUS IMAGES ON THE HOME SCREEN	46		
4.2.5 CONTROL PANEL USER SETTINGS	48		
4.2.6 CONTROL PANEL OPERATION SETTINGS	50		
4.3 DAILY OPERATING INSTRUCTIONS	54		
5. CHAPTER / MAINTENANCE	55		
5.1 PREVENTIVE MAINTENANCE INTERVALS	55		
5.1.1 GENERAL DESCRIPTION	55		
5.1.2 DAILY MAINTENANCE	56		
5.1.3 WEEKLY MAINTENANCE	56		
5.1.4 COMPRESSOR MAINTENANCE INTERVALS	57		
5.1.4.1 AIR-END AND MOTOR	58		
5.1.4.2 OIL SPECIFICATION, CHECK AND REPLACEMENT	58		
5.1.4.3 OIL FILTER AND SPIN-ON SEPARATOR REPLACEMENT	63		
5.1.4.4 CLEANING AND REPLACEMENT OF AIR INTAKE FILTER	66		
5.1.4.5 INSPECTION AND REPLACEMENT OF SAFETY VALVE	67		
5.1.4.6 REPLACEMENT OF MINIMUM PRESSURE VALVE	68		
5.1.4.7 REPLACEMENT OF THERMOSTATIC VALVE	69		
5.1.4.8 CHECK AND REPLACEMENT OF AIR INTAKE VALVE (SUCTION FLAP)	70		
5.1.4.9 INSPECTION AND REPLACEMENT OF COUPLING	71		
5.1.4.10 INSPECTION AND CLEANING COOLING GROUP	71		
5.1.4.11 OIL TEMPERATURE SENSOR REPLACEMENT	72		
5.1.4.12 MAINTENANCE AND REPLACEMENT OF CABINET FILTERS AND HOSES	73		
6. CHAPTER / FAILURES AND SOLUTIONS	74		
7. CHAPTER / TECHNICAL DATA	79		
7.1 COMPRESSOR NAMEPLATE	79		
7.2 COMPRESSOR DATA	80		
7.3 POWER CABLE DIMENSIONS	81		
7.4 PRELIMINARY FUSE ON SITE	82		
7.5 FUSE SPECIFICATIONS BY COMPRESSOR	83		

THE DETAILS THAT DELIVER THE RIGHT RESULTS...

EXPERIENCE

Ozen Air Technology, with its industry experience of half-a-century and its large portfolio of compressed air products, provides reliable, efficient, and smart solutions

TRUST

Ozen's dedication to customer satisfaction has helped the company to build lasting relationships of trust and loyalty with its customers.

DURABLE AND EFFICIENT

All of the compressed air equipment in Ozen's portfolio have proven their durability under the toughest conditions. They provide high-quality, high-efficiency air.

QUALITY

Consistently manufacturing high-quality products is one of Ozen's fundamental tenets. To that end, Ozen continuously enhances its quality policies.





TECHNOLOGY

Ozen Air Technology is innovative. It always uses up-to-date technologies in compliance with world-standards.

R & D

With its creative team and competent infrastructure, Ozen is capable of developing its own technology through collaborations with several universities.

STRONG SERVICE NETWORK

Ozen Air Technology believes in maintainability. Its customers can enjoy uninterrupted manufacturing thanks to its accessible, fast, and reliable service network.

COMPETITIVE

Ozen Air Technology acts in favor of its customers. Providing them with leverage is one of Ozen's strong suits.

RESPECT FOR THE ENVIRONMENT

Striving for a sustainable future, Ozen Air Technology selects for environmentally friendly practices and takes all necessary precautions while structuring its work processes.

SAFETY

CHAPTER 1

1.1 SAFETY SYMBOLS AND GENERAL SAFETY MEASURES

This manual must be read in its entirety and completely understood in order to operate the compressor safely and correctly. The safety instructions must be read carefully and all warnings must be strictly adhered to. Follow all local requirements, such as lock-out/tag-out procedures and the wearing of proper personal protection equipment, before attempting to service this equipment.



HOT OIL AND COMPRESSED AIR

Before replacing the separator, make sure the system is switched off and the air in the system is completely evacuated. Otherwise, when the system is loosened, there may be an explosion or skin burns when touched.



FLAMMABLE OIL

Exercise caution when working near or with oil. Do not expose oil to open flames and refrain from smoking near oil storage areas.



ROTATING PARTS

Make sure that your hands and body are kept safely away from the fan area before operating the compressor. Severe injuries can occur if your hands or body are stuck in the rotating parts.



RESPIRATORY DISORDERS

Air discharged from the air compressor may contain oil and particulates. It is hazardous to directly inhale the air from the compressor.



COMPRESSED AIR

The air pressure exiting the compressor may be powerful. Ensure that the air outlet is tight and properly sealed before operating the compressor.

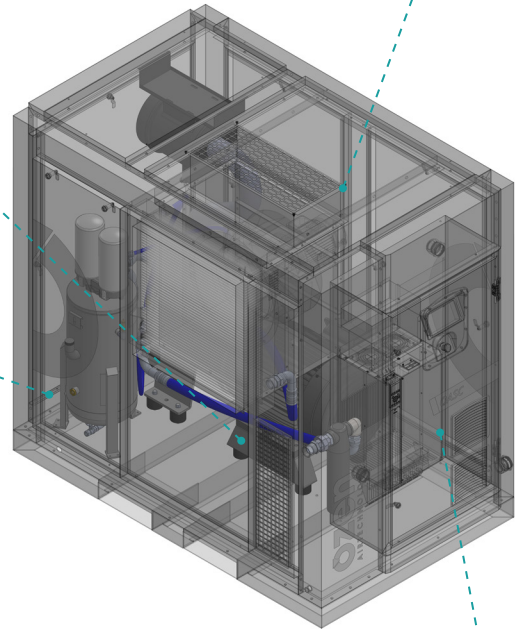

ELECTRIC SHOCK

Make sure that the power is disconnected and proper lock-out/tag-out is performed before connecting the compressor to the power supply or before servicing. Do not open the electrical cabinet cover before the power is turned off.



ELECTRIC POWER

Do not apply power until the installation is complete. Compressor must be properly grounded and adhere to local electrical codes.



FIRE

Perform proper oil level checks per the maintenance schedule. A low oil level may cause the machine to overheat. Although the oil has a high auto-ignition value, fire can occur in very extreme cases. Proper grounding is required on all electrical circuits.



HOT OIL PRESSURE

Before replacing the compressor oil, stop the compressor and make sure that the air is completely evacuated.



OIL LEVEL CHECK

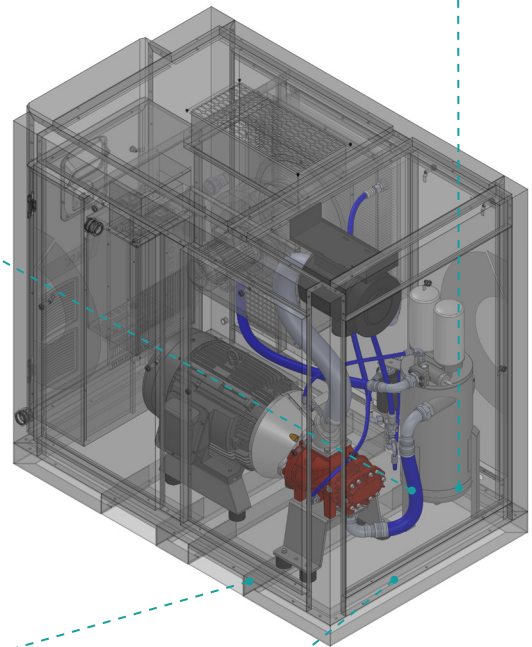

ROTATING PARTS

Make sure that your hands and body are kept safely away from the belt and pulley area before operating the compressor. Severe injuries or death may occur in cases when your hands or body are caught in the rotating parts.



HAND CAUGHT IN THE COVER

Exercise caution when removing or installing machine panels. Panels can become pinch points, especially when the machine is operating.

SAFETY

CHAPTER 1

GENERAL WARNING ICONS



IMPORTANT!

This symbol and the word "IMPORTANT!" contain important information about the use of the compressor. Read the information in these sections thoroughly for the compressor to be operated efficiently.



ATTENTION!

This symbol and the word "ATTENTION!" indicate the possible hazards that may be caused to the person and the environment. Failure to observe the warnings in this section may cause personal injury.



DANGER!

This symbol and the word "DANGER!" indicate the potential hazards that may be encountered. If ignored, it may result in serious personal injury or death.

GENERAL SAFETY ICONS

Read the general safety icons and descriptions carefully before using your compressor. Observe the safety notes in the sections in which you see these icons. Failure to observe safety icons may result in injury or death.



HOT OIL AND COMPRESSED AIR

Machine contains hot oil and compressed air. Exercise caution when performing any service work or repair. System pressure must always be completely relieved any time the system is opened. Failure to do so may result in equipment damage, person injury, or death.



FLAMMABLE OIL

Machine contains hot oil under pressure. Exercise caution whenever working with the oil system and never perform any service or repair while machine is under pressure or in operation.

**ROTATING PARTS**

Keep away from the rotating parts (fan, etc.) when the compressor is running. Contact with rotating parts may result in serious bodily harm or death.

**ROTATING PARTS**

Keep away from the rotating parts (belt and pulley system, etc.) when the compressor is running. Contact with rotating parts may result in serious bodily harm or death.

**ELECTRIC SHOCK**

Do not come into contact with live electrical components and/or cables. Doing so will result in electric shock, leading to severe injury or death. Always wear appropriate PPE (Personal Protective Equipment) per NFPA 70E and local regulations.

**PINCH POINT**

Keep hands away from the openings when removing or installing machine panels, especially when the machine is in operation. Suction from the machine may cause fingers or body parts to become pinched, causing injury.

**HOT SURFACES**

Do not touch the hot surfaces of the compressor when the compressor is operative or inoperative. Doing so may cause injuries.

**RESPIRATORY DISORDERS**

Do not breathe compressed air discharge. It is not meant for breathing air and can cause respiratory damage.

**EARPLUG USE**

Use earplugs while the compressor is running. Otherwise, you may experience hearing loss.

**ELECTRIC POWER**

Do not perform any work or repairs on live electrical circuits. Always remove electrical power, perform lock-out/tag-out procedures, wear proper PPE, and take safeguards to provide protection against electrical shock. Electrical shock will cause serious injury or death.

INSTALLATION

CHAPTER 2

2.1 HANDLING AND INSTALLATION OF THE COMPRESSOR

Compressors can be transported by crane or forklift. Compressors may fall or be tipped due to improper transport. This will cause serious damage to the compressor and/or personal injury or even death.

Transport of a compressor by forklift:

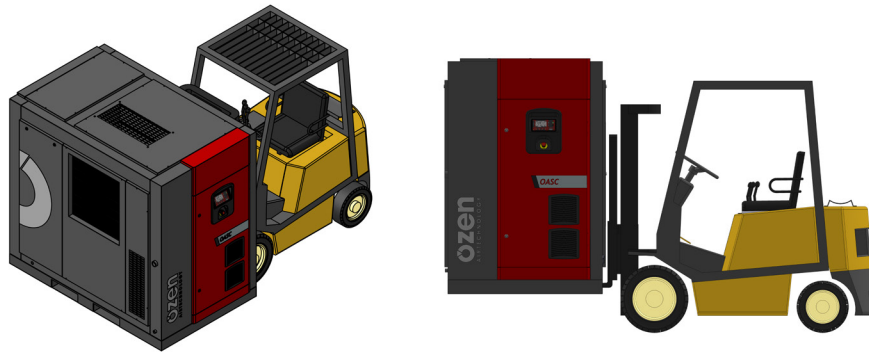

PROPER TRANSPORTATION

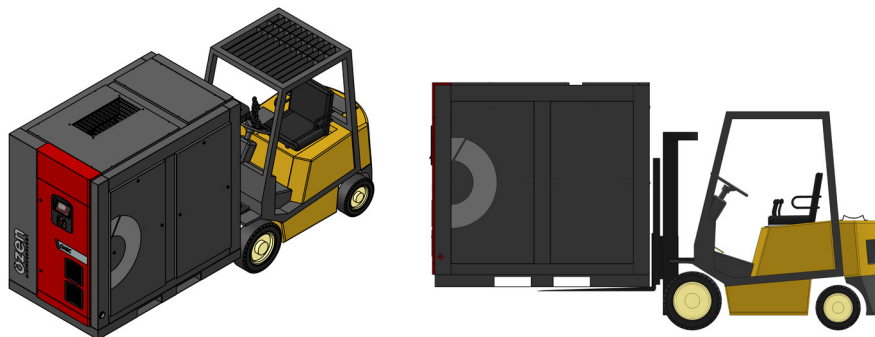

IMPROPER TRANSPORTATION

- ▶ For the stable lifting of the compressor, the forks of the forklift must be equally inserted into the forklift slots located on the sides of compressors and lifted. If the directions are not followed, the compressor can overturn and cause serious damage to the compressor or personal injury.
- ▶ The forklift's lifting mast must not be inclined forward when lifting the compressor.
- ▶ The front and rear floor openings of the compressor are not intended for the forklift. Do not use them for lifting purposes. Only use the forklift slots on the sides reserved for the forklift.
- ▶ Select a suitable forklift that is recommended for the weight of the compressor.



ATTENTION!

If the weight of the truck to be used to transport the compressor transport is not selected according to the size of the compressor, then the forklift may incline forward and tip over due to excess weight. This will lead to substantial material damage and/or personal injury.

INSTALLATION

CHAPTER 2

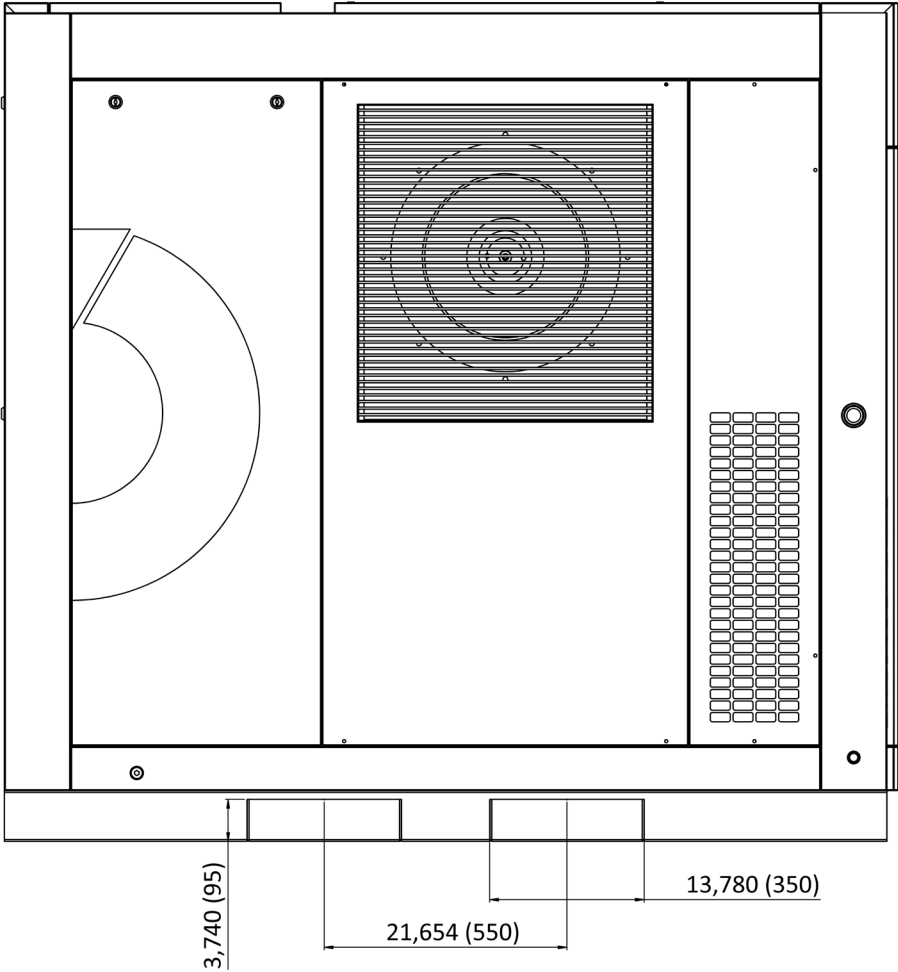

NOTE: Unless noted otherwise, all measurements in FIGURES are in inches (mm)

Transportation of the compressor by crane:



- ▶ In order to lift the compressor in a balanced way, rope should be placed through the forklift slots that are on the front and back of the compressor. Ropes should be of equal length.
- ▶ While the ropes are being set, wood slats need to be placed between the ropes and cabinet as shown in FIGURE-6. This will prevent damage to the cabinet.
- ▶ Since both sides of compressor aren't suitable to be lift by crane, please only use the forklift slots that are on the front and back of the compressor.



ATTENTION!

Do not stand under and near the compressor when transporting the compressor by crane. Failure of the lifting devices will cause the load to fall, causing personal injury or death.

INSTALLATION

CHAPTER 2

Installation of a compressor:

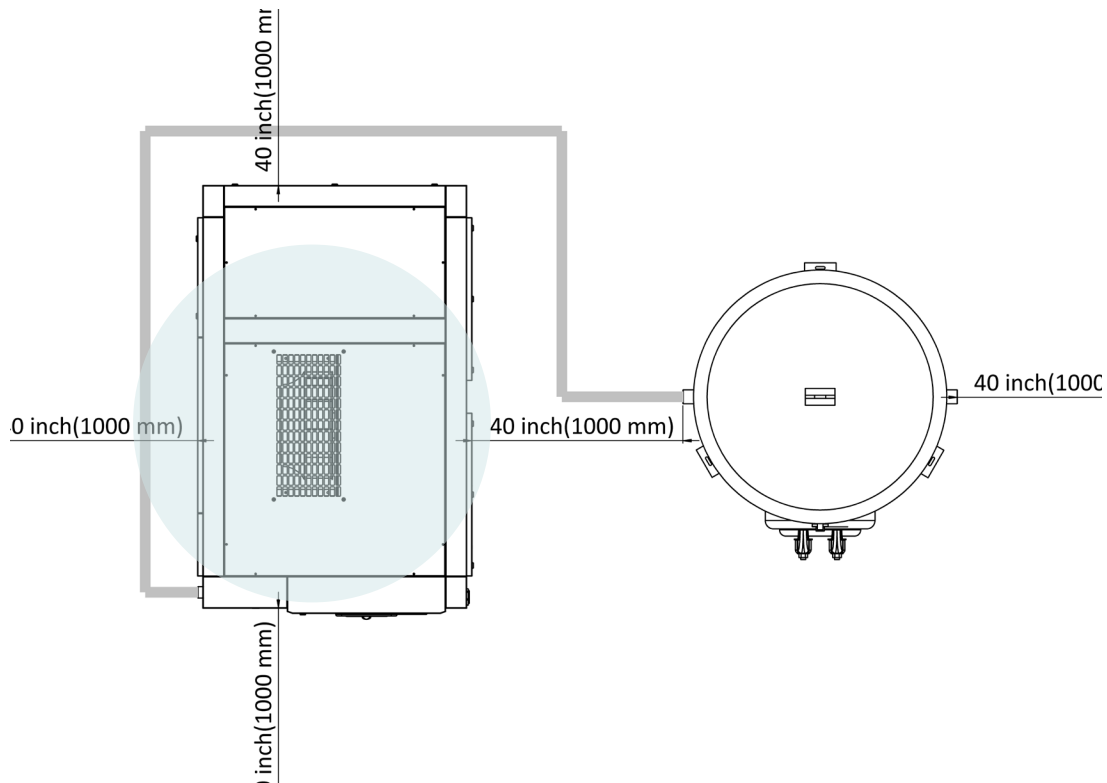

The following considerations should be taken into account before locating a compressor:

- ▶ The floor for the compressor must be flat.
- ▶ Ensure that the dimensions and ventilation of the compressor room are appropriate.
- ▶ The compressor room must have enough lighting.
- ▶ Provide the appropriate power supply to the compressor.
- ▶ Take appropriate fire precautions per local laws and regulations.
- ▶ Compressor accessibility must adhere to recommended clearances and all escape routes and rescue equipment must be accessible.
- ▶ The compressor room must be free of dust.
- ▶ No electrical or electromagnetic devices that may cause disturbances should be around the compressor room.
- ▶ Make sure that the compressor is not directly exposed to rain, moisture, and extreme low and high temperatures.
- ▶ Ensure that the compressor is not directly placed in a corrosive environment.
- ▶ Provide the compressor room with a fixed or portable crane in order to facilitate the maintenance and servicing operations.

**ATTENTION!**

The temperature and humidity (climatic conditions) of the environment in which the compressor is to be placed has an effective role in the operation of the compressor. Ensure that adequate protection is provided to the ambient conditions

When locating a compressor:

- ▶ The compressor must have a minimum clearance of 40 inches (1000 mm) between the walls and the other components in the room (if any) to allow for unobstructed air intake and discharge. There must be at least 60 inches (1500mm) between compressor and the roof. These are very important dimensions for easy servicing. Service personnel may not be able to fulfill their work if these dimensions are less.
- ▶ Install separate lines for the condensate drains of the compressor, dryer, filters, and air receiver. Otherwise, water may gather in the vicinity of the air compressor.
- ▶ The air inlet sides of the compressor cabinets must always face in the direction of cool air. Take this into consideration when designing the layout of the room and placement of the compressor.
- ▶ The room where the compressor is to be operated must have an appropriate air flow. The compressor must not draw in the hot air that is discharged from compressor. The clean and cool air entering the room must have a velocity of less than 13 ft/sec (4 m/sec.).
- ▶ On the models equipped with an aftercooler, there may be some oil in the water that is discharged from the compressor. An oil/water separator may be required before disposing the water into the drain. Check the local environment and safety standards that you are subject to.

INSTALLATION

CHAPTER 2

2.2 VENTILATION AND COOLING

The heat generated by the air compressor can quickly increase the compressor room ambient temperature beyond the maximum rated ambient temperature for the machine. In order to prevent this, ventilation for the compressor room must be provided. Please refer to the Cooling & Ventilation Data chart on page 17.

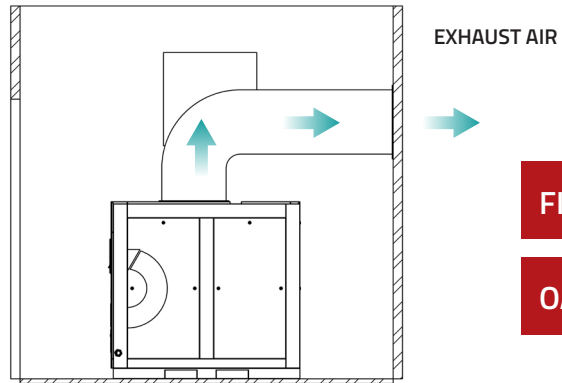
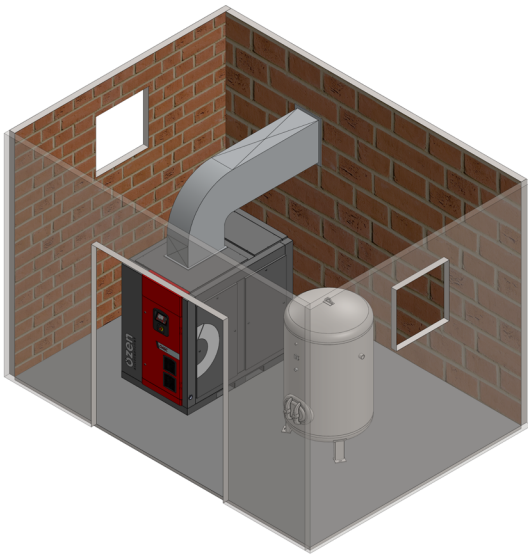

FIGURE A

OASC D 55

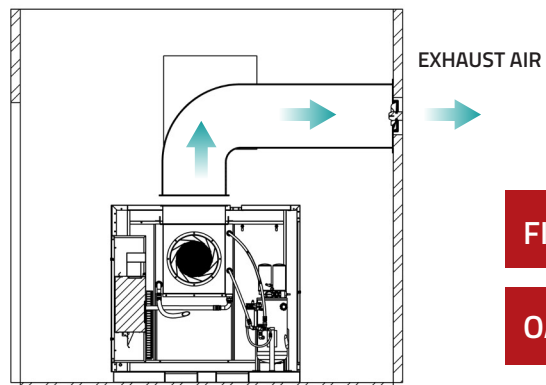
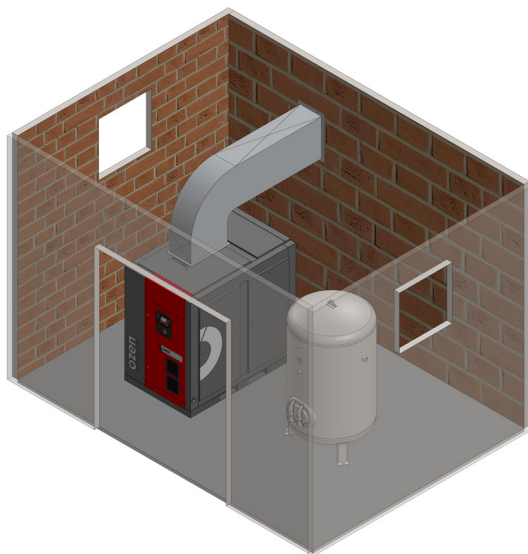

FIGURE B

OASC D 55

The compressor room ventilation blowers are recommended to be on the air intake side of the compressor. This allows the compressor to reach clean air more easily and quickly.

Avoid long runs of ducting and keep bends to a minimum, especially those that are 90 degrees. Ducting must be at least as large as the opening on the hot air discharge of the compressor and must be over-sized in instances of long runs and excessive bends. Failure to do so will result in back-pressure being applied to the cooling fan, which will cause the compressor to overheat. Refer to Table-1 for cooling data and back-pressure limits to assist in sizing and engineering of duct work.

If the difference between the outlet pressure of suction fan in the compressor and the outlet pressure of the ventilation duct system is less than defined value below at Table-1, then FIGURE A is preferred. If greater, then FIGURE B is preferred.

If FIGURE B is preferred, the gap (h) between the compressor and ventilation hood must range between 8-12 inches (200 - 300 mm).

Cooling & Ventilation Data		
Model:		OASC D 55
Heat generation BTU/h (MJ/h)		187,667.81 (198.0)
Air Exhaust cfm (m³/min)		5650 (160)
Fan Capacity	Ventilation Type A cfm (m³/min)	N/A
	Ventilation Type B cfm (m³/min)	6003 (170)
	Ventilation Type C (without duct) cfm (m³/min)	14125 (400)
	Pressure loss allowed " H2O (Pa)	0.18 (45)

Table 1

In order to prevent the re-circulation of hot air exhaust, the inlet air vent to the compressor room must not be located on the same wall as the hot air exhaust. It is best to locate the two vents on opposite walls for cross-ventilation or at least on an adjacent wall, as shown on the figures.

Air intake grills installed in the compressor room must be designed so as to prevent ingress of water (rain) and debris (leaves, dust, etc.)

INSTALLATION

CHAPTER 2

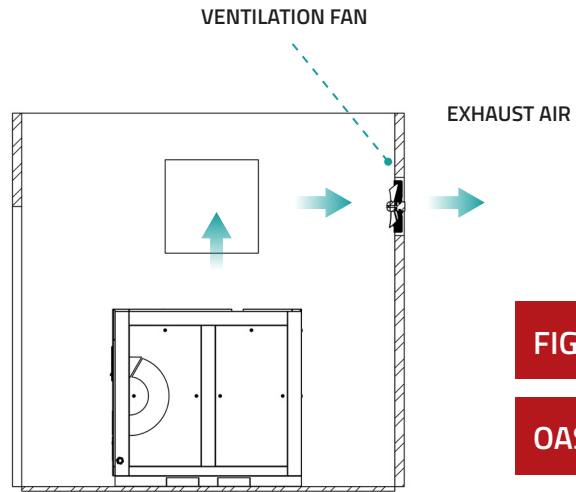
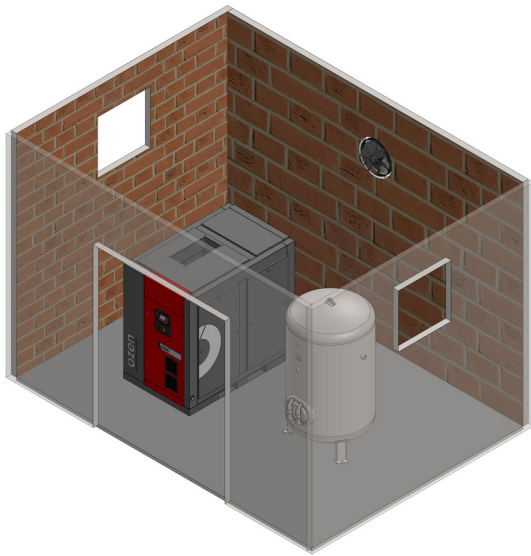

FIGURE C

OASC D 55

When a fan is used for the purpose of hot air exhaust removal, the capacity of the fan must be as close as possible to that of the air compressor cooling fan. Failure to size the exhaust fan properly will result in the pulling of a vacuum in the room or inadequate evacuation of the hot hair exhaust, which may result in overheating of the compressor.

Placement of the intake and discharge grills may differ from the figure due to actual placement of the air compressor.

2.3 SERVICE AIR PIPES

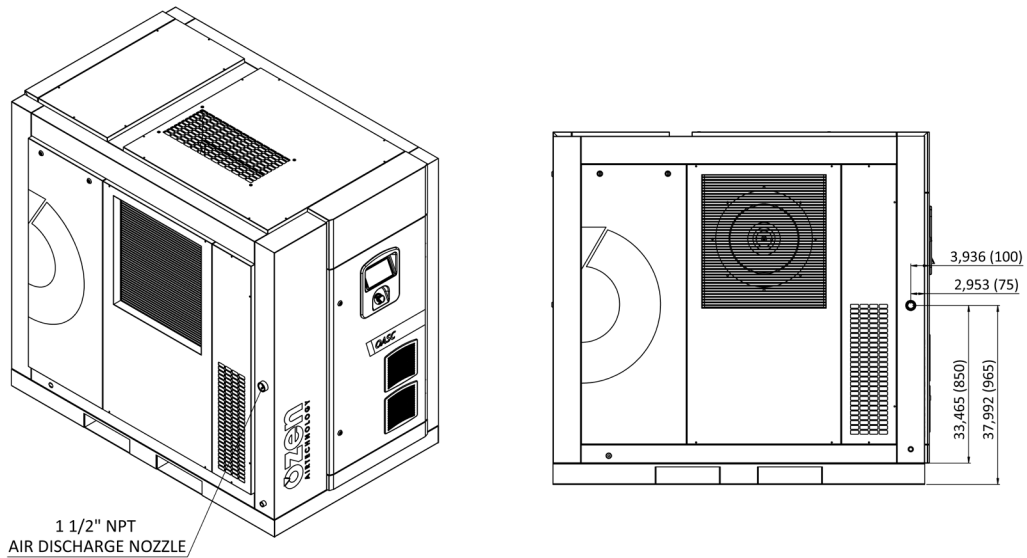

Compressor service air outlet is found on the side of OASC D 55. Dimensions are defined in Table 2.

MODEL	AIR DISCHARGE SIZE
OASC D 55	1 ½" NPT
OASC 55	1 ½" NPT

Table-2



IMPORTANT!

The table located on the left demonstrates the diameters of air outlet hose related to the Ozen Air Technology rotary screw air compressors mentioned in this manual.

System piping size must never be smaller than the size of the air compressor discharge. Reducing the piping size will result in overpressurization of the compressor.

INSTALLATION

CHAPTER 2

2.4 ELECTRICAL CONNECTION



DANGER!

Always verify that the power supply is de-energized when making any electrical connections. Failure to do so may result in electric shock, which will cause bodily harm or death.

All electrical connections should be made by a Licensed Electrician or a qualified Ozen Distributor Service Professional. Incoming power connection must be made through the cabinet penetration shown below in Detail A.

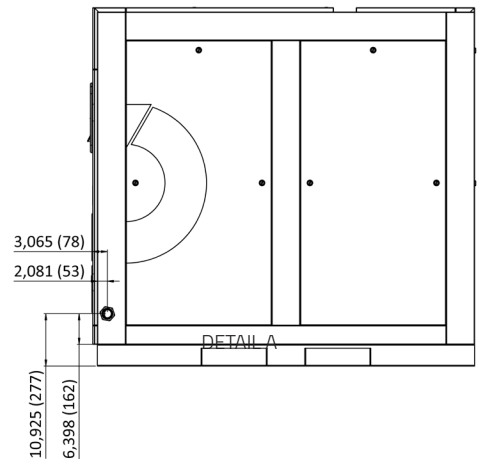
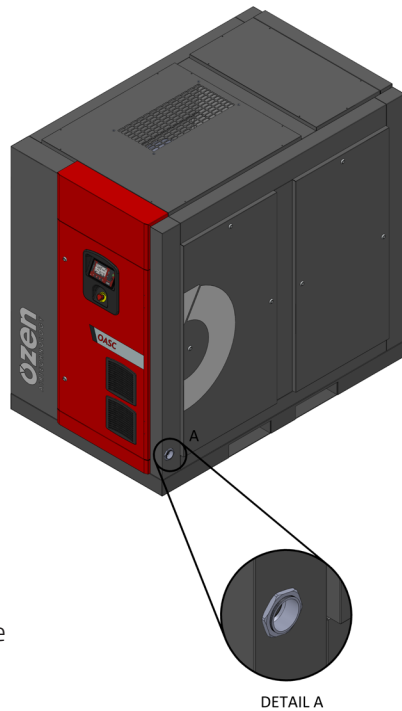

Fulfill the power connection with cables having UL-Standard as per electrical connection diagram. Carefully examine the data in the electrical diagram. Check that your supply network is in compliance with this data. Maximum voltage deviation is +/- 10%, maximum voltage drop when compressor is started is 10%, and maximum sustained voltage drop after the compressor is running is 6%. Maximum voltage imbalance is 1% and maximum current imbalance is 5%.

Note: All measurements are in inches (mm)



When selecting the power cable size, refer to the Total Loaded Power for the main motor which is specified in the “Engineering Data Sheets”.

Use Table 11 in Chapter 7.3 to select the electrical cable. This table shows the power connection cable dimensions for each kW motor. All cabling, main fuses, and main breakers must be sized applicable to local electrical codes. Any references in this manual are suggestions, only.

When connecting the power cables, ensure that they are properly secured so as to not create a tripping hazard. Make sure that the power cables are securely tightened to the connection terminals.

If the phase connections are wrong, either the motor will turn in the opposite direction or the compressor will not operate. Check the rotation direction of the motor when you operate the compressor for the first time. If the rotation direction is not correct, swap two of the incoming power lines to reverse rotation.

Always verify that the machine is wired to the correct voltage that matches your incoming power by checking the label inside the electrical panel door and the compressor data tag located on the outside of your compressor. To convert your compressor to a different voltage, please contact your local Ozen Distributor.

A fused disconnect or circuit breaker according to PRELIMINARY FUSE ON SITE - PFS (A) list and code requirements must be provided by the customer. The PFS (amps) value is available at table 12 section 7.4



ATTENTION!

The grounding cable must be attached to the terminal block during the installation of incoming power. The terminal reserved for the grounding cable is located next to the incoming power phase connections. If this is not completed, the entire compressor can become electrified and electric shock can occur, causing bodily injury or death.

INSTALLATION

CHAPTER 2

2.4.1 ELECTRIC DIAGRAMS

ELECTRIC DIAGRAM FOR OASC D 55

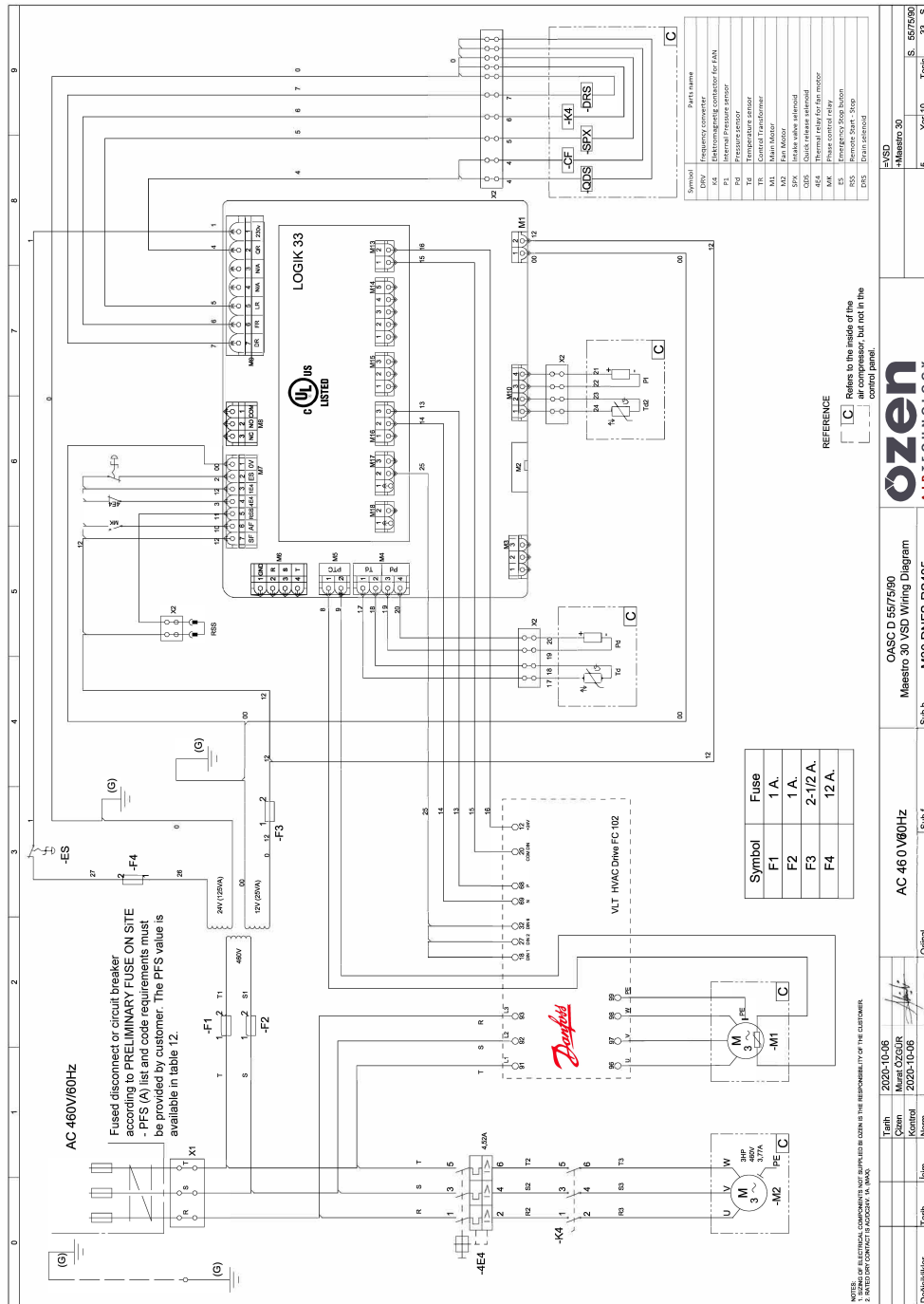

2.5 INSTALLATION CONTROLS

2.5.1 COUPLING COVER CONTROL

- ▶ In an OZEN AIR TECHNOLOGY direct coupled system, the electric motor and air end connect to each other by the aid of a coupling.
- ▶ To ensure that the electric motor and air end connection is properly aligned, an electric motor flange is used.
- ▶ Refer to coupling control and changing in Section 5 for more information.
- ▶ If you detect any problems with the coupling system while the compressor is running, immediately shut down the compressor and take necessary measures to secure it against accidental restart. Contact your local Ozen Distributor for analysis and repair.

INSTALLATION

CHAPTER 2

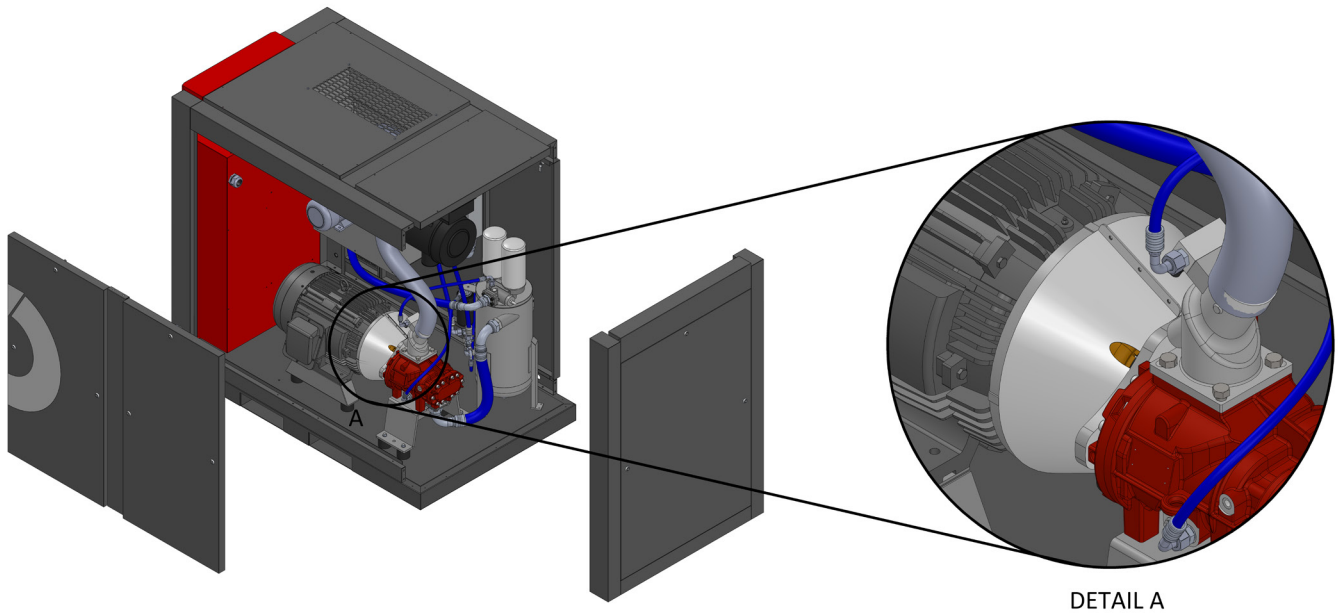

DETAIL A



ATTENTION!

Do not operate the compressor with any cabinet panels removed.



2.5.2 OIL LEVEL CHECK

The oil necessary for the operation of the compressor is contained inside of the separator tank. Check the oil level before operating for the first time and then on a daily basis thereafter.

Check the oil level when the compressor is not operating. The correct oil level can not be determined when the compressor is operating. Allow at least 10 minutes after the compressor has stopped operating before checking the oil level. Check the oil level on the sight glass located on the separator tank.

The required oil level should be at least half of the sight glass. The oil level should not completely fill the sight glass. If it is completely filled, there may be a compressor malfunction due to the high oil level. A high oil level will also result in excessive oil carry-over into your system piping. This will foul any in-line filter elements and cause coating and failure of the desiccant inside of a desiccant air dryer, if present.



✗ Completely Empty Tank



✓ Half full Tank



✗ Completely full Tank

If there is no oil observed on the sight glass, the compressor must be immediately shut down and measures must be taken to prevent the compressor from being started again. Contact an authorized Ozen Distributor for analysis and repair.

INSTALLATION

CHAPTER 2

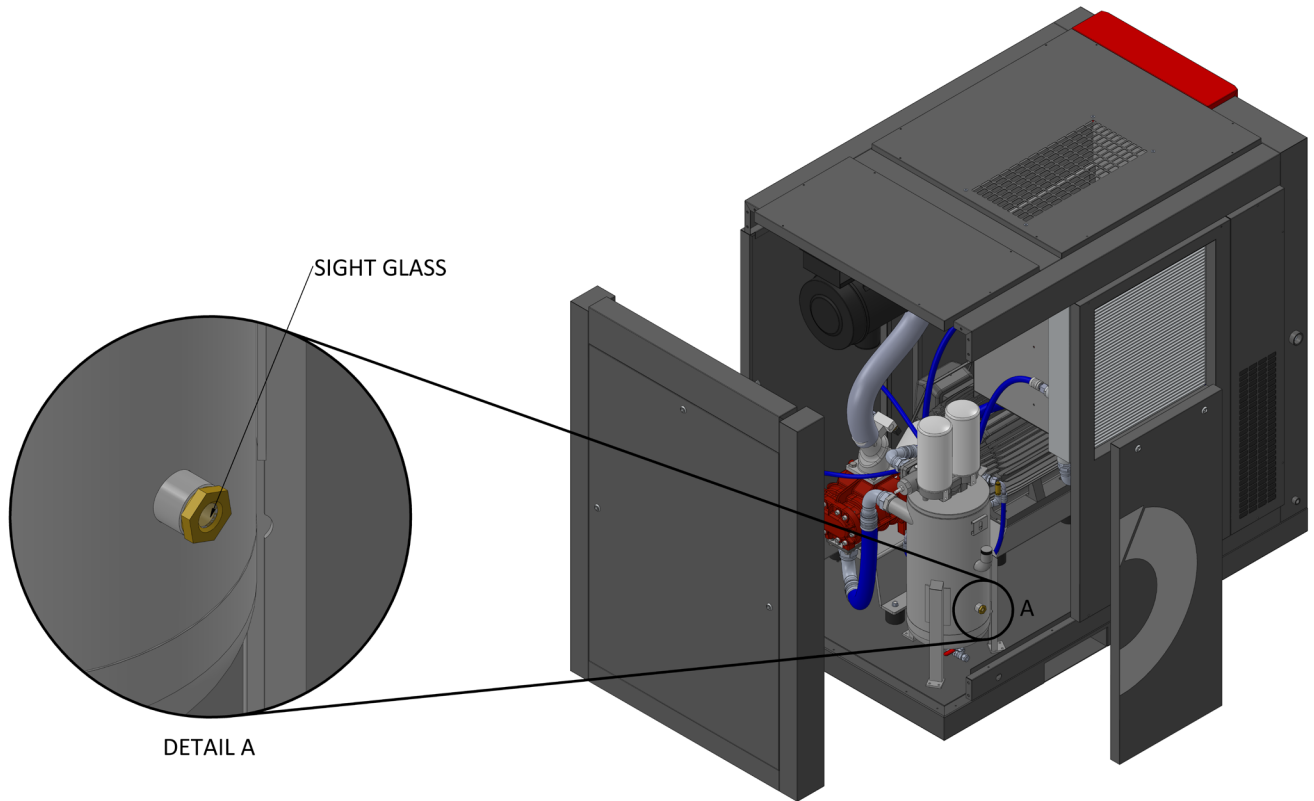

ATTENTION!

Always ensure that the oil fill plug has been reinstalled and tightened after removal to add oil. Do not operate the compressor with any cabinet panels removed.



2.5.3 MOTOR ROTATION DIRECTION CONTROL



Although Ozen Air Technology installs phase reversal protection to ensure proper motor rotation on each and every compressor that is manufactured, it is recommended to manually verify that correct motor rotation is established. Verify correct rotation according to the arrow decal placed on the motor.

A phase sequence relay communicates with the Maestro controller and will prevent starting of the compressor if incorrect rotation is sensed.



ATTENTION!

Do not operate the compressor with any cabinet panels removed.



THE SYSTEM OF COMPRESSOR

CHAPTER 3

3.1 INTRODUCTION/DEFINITION

This chapter shows the general components constituting the Ozen Air Technology rotary screw air compressors. Ozen Air Technology compressors are air-cooled, oil-injected, electric motor driven screw compressors.

All components of the Ozen Air Technology screw air compressors are assembled in a closed steel sheet-metal casing providing sound insulation.

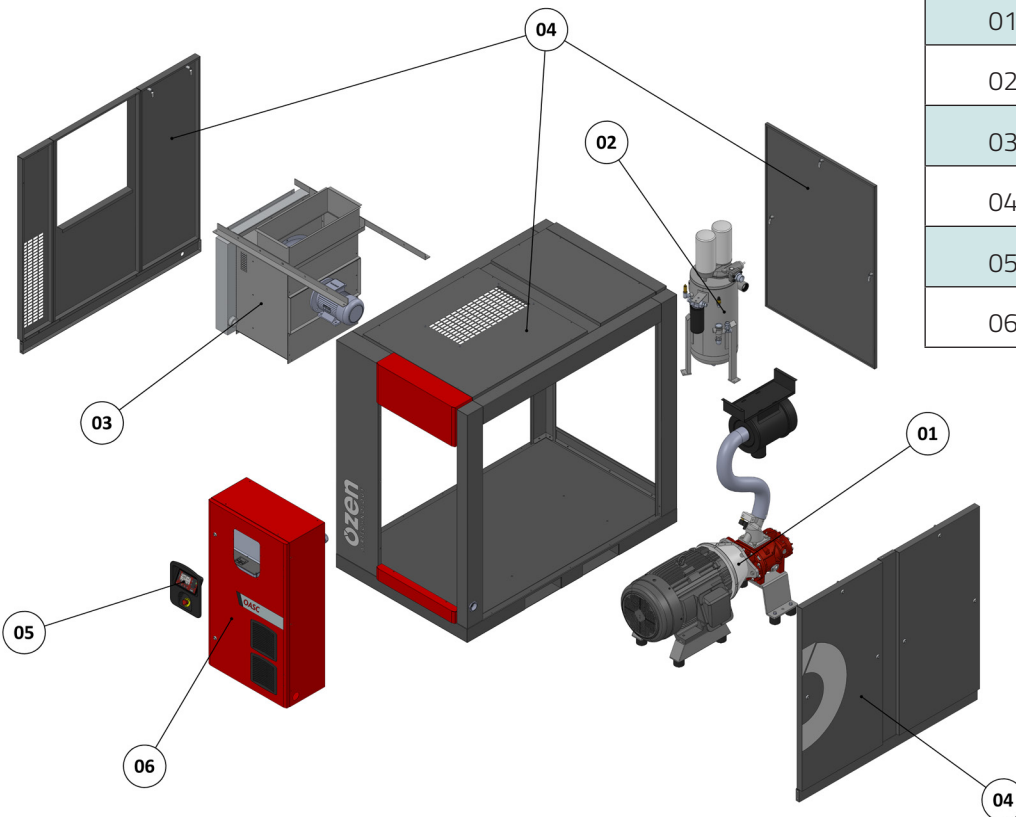

01	Motor & Air-end Group
02	Separator Tank
03	Cooling System
04	Compressor Cabinet
05	Operator Panel
06	Electric Cabinet

3.2 COMPONENTS

3.2.1 MOTOR & AIR-END GROUP

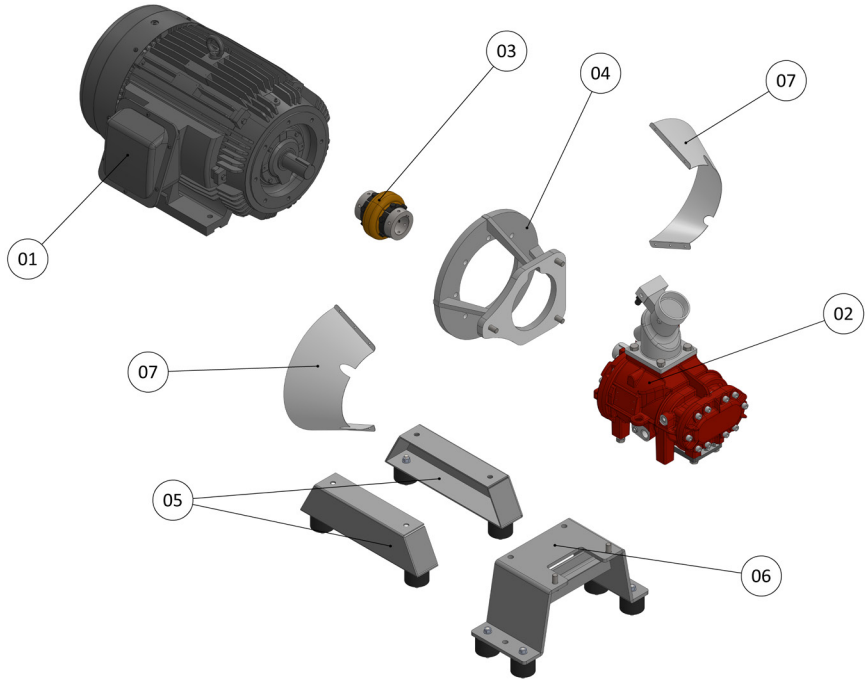

01	Electric Motor
02	Air-End
03	Coupling
04	Motor Flange
05	Motor Support
06	Air-End Support
07	Flange Cover

The motor and air-end system of the compressor performs the compression of the air. Atmospheric air is pulled through the intake filter and valve by the air-end.

The air is then compressed by two rotors present in the air-end and sent to the separator tank for oil removal.

The air-end rotors are driven by an electric motor through a coupling system.

The motor and air-end group is mounted on a base plate. Please refer to the parts manual for detailed pictures.

3.2.1.1 ELECTRIC MOTOR

The electric motor is selected by the appropriate voltage, frequency, and motor speed according to the customer requirements.

The electric motor ensures the rotation of the air-end rotors and, hence, the production of compressed air.

All Ozen Air Technology compressors utilize electric motors that are listed as NEMA Premium Efficiency.

Motor efficiencies can be found in the Engineering Data Pages by compressor model.

The maintenance and replacement of the motor bearings are to be made in accordance with the maintenance chart.

THE SYSTEM OF COMPRESSOR

CHAPTER 3

3.2.1.2 AIR INTAKE GROUP

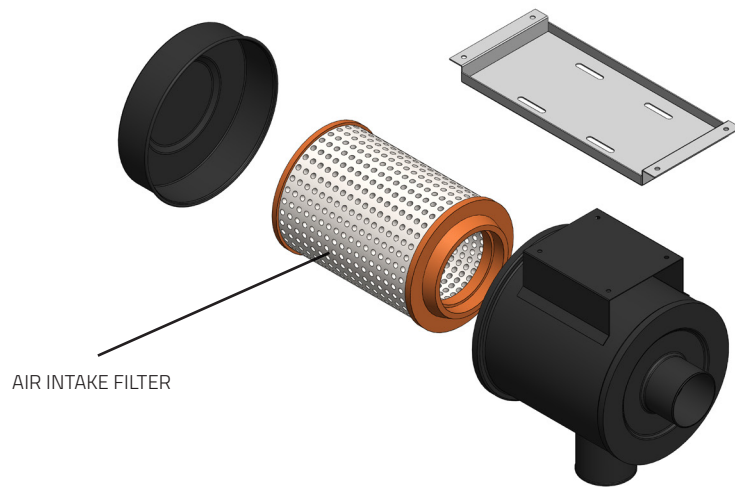

If the air ingested by the compressor contains dust or dust particles, the following may happen:

- Damage to the air-end rotors
- Reduced optimal working life of the oil.

The contaminated oil could also clog the oil separator and shorten its service life.

The first measure to combat these issues is to ensure that the air intake filter element is clean. If it is dirty, clean it with compressed air or replace the element.

Replacement of the air intake filter is carried out according to the maintenance schedule that you can find in the maintenance and cleaning methods in the "Section 5.1.4.4 Cleaning and Replacement of air intake filter".

Air Intake Valve

The air intake valve controls the amount of air that is ingested by the compressor and the amount of air compressed. When the air intake valve is fully open, the compressor operates at full load and produces compressed air at full capacity. When the air intake valve regulator valve is closed, the compressor runs idle and does not supply air to the system.

Installation of an inlet valve repair kit is to be performed according to the maintenance schedule.

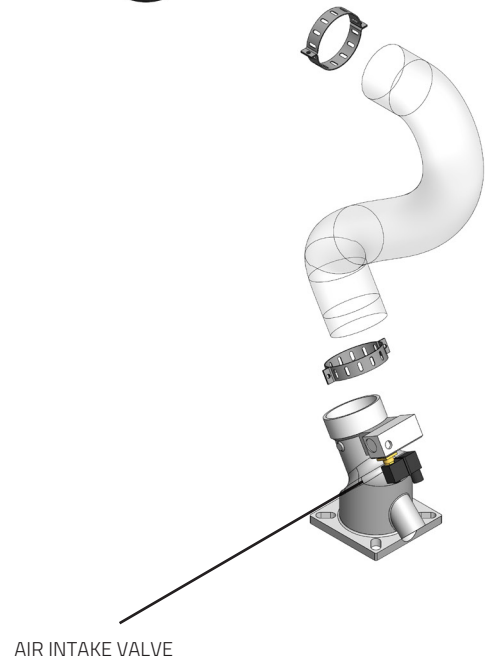

3.2.1.3 SEPARATOR GROUP

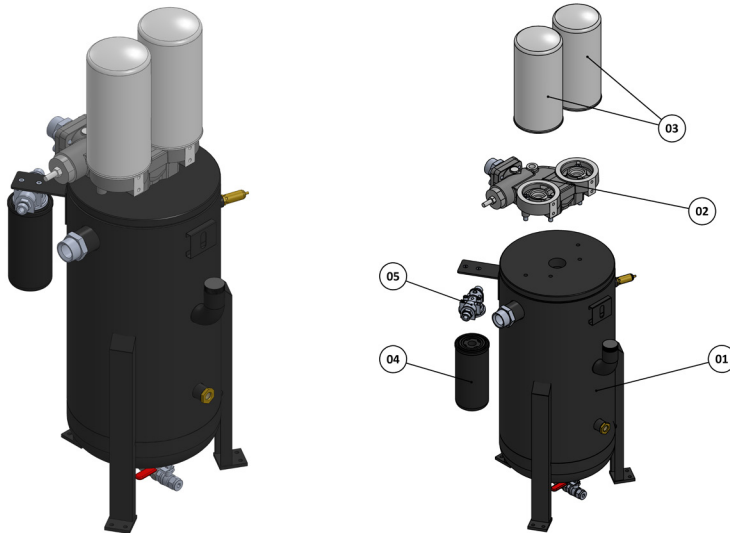

01	Separator tank
02	Separator block
03	Separator
04	Oil Filter
05	Oil Filter Head

3.2.1.3.1 SEPARATOR TANK

A compressed air/oil mixture is delivered to the separator tank from the air-end. The separator tank acts as a holding sump for the oil.

Lubrication of the system is carried out with the internal pressure created by the minimum pressure valve in the separator combination block.

The oil in the separator tank first passes through the thermostatic valve. If the oil temperature is less than 131 ° F, the oil will then pass through the thermostatic valve to the oil filter to be cleaned. From there the oil will enter the air-end and finally back to the separator tank. If the oil temperature is higher than 131 ° F, the oil will pass through the thermostatic valve to the oil cooler before entering the oil filter.

The oil/air mixture coming out of the air-end is separated to a large extent with the help of gravity and a centrifugal effect in the separator tank.

The remaining oil is separated from the air in the separator element. Oil is returned to the air-end and the air passes through to the minimum pressure valve.

Separator tanks comply with ASME UM Stamp standards.

On the separator tank there is also a separator combination block and spin-on separator element and oil filter.

THE SYSTEM OF COMPRESSOR

CHAPTER 3

3.2.1.3.2 SEPARATOR BLOCK

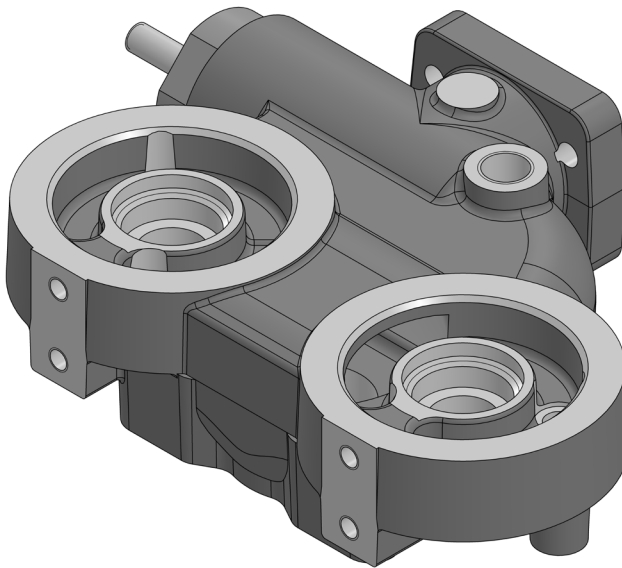

The separator combination block is a part that allows for the installation of spin-on type air separators and oil filters on a single structure. It also includes the minimum pressure valve, thermostatic valve, safety valve, and scavenge line oil gauge. The safety valve and scavenge line oil gauge is replaced along with the minimum pressure valve and thermostat valve set during the course of maintenance.

In addition to its low cost and simple installation, it is a system that has a mono-block structure occupying less space, which minimizes the risk of leakage and allows for minimum pressure drop.

It is utilized from 4 kW up to 55 kW without issue.

Refer to the maintenance schedule for information on required maintenance to items contained in or on the combination block.

3.2.1.3.3 SEPARATOR

The oil separator element's primary function is to separate the remaining oil from the air that was not completed by the separator tank. Keep in mind that filtration is not the primary function of the separator element. Failure to replace the air filter and oil filter as recommended or contamination of the oil system will force the separator element to function as a mechanical filter and will shorten its life.

3.2.1.3.4 OIL FILTER

It is the filter used to clean the oil circulating in the compressor.

If the oil is not filtered properly, contaminants will enter the air-end and score the rotors and/or plug internal lubrication passages. Over time, this will shorten the life of the air-end, causing the compressor to become inoperable.

The oil filter is replaced according to the maintenance schedule.

Failure to use genuine Ozen parts and/or failure to replace the filter at the required interval in the maintenance schedule will void any warranty.

3.2.1.4 AIR-END

The air-end is equipped with a set of rotors, which are capable of compressing air up to 190 psi, dependent upon the set of pulleys used. Once the air is compressed, the air/oil mixture is delivered to the separator tank.

Never operate the compressor without the appropriate level of oil in the separator tank. This can lead to the air-end being severely damaged.

The air-end is to be maintained pursuant to the maintenance schedule.

3.2.1.5 DIRECT COUPLED SYSTEM

The electric motor and air-end shafts (male rotor) are connected to each other via a coupling. Proper alignment of the motor shaft and air-end shaft is crucial for the healthy operation of compressor. In a direct coupled system, the rpm of the air-end is equal to the rpm of the electric motor.

Premium high efficiency Viva couplings are used in Ozen Air Technology direct coupled systems, minimizing the torsion between the motor and air-end.

3.2.1.6 ELECTRIC MOTOR SUPPORT AND AIR END SUPPORT

Motor and air-end supports are made of sheet metal and are optimally designed to assure healthy operation. These components have a significant role in maintaining the alignment of the motor and air-end shafts.

THE SYSTEM OF COMPRESSOR

CHAPTER 3

3.2.2 COOLING SYSTEM

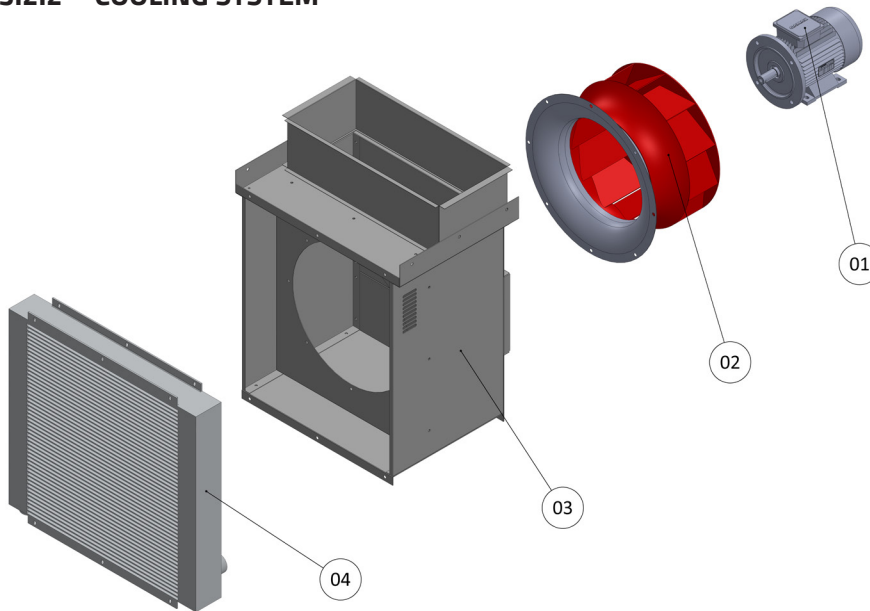

01	Fan motor
02	Radial fan
03	Ventilation Hood
04	Cooler

Air and oil are cooled in the cooler, which is a part of the cooling system.

The cooled oil is sent back to the system whereas the cooled air is sent out of the compressor.

3.2.3 CONTROL PANEL

The compressors included in this manual use the Maestro 30 control panel.

Below you will find general information about Maestro 30.

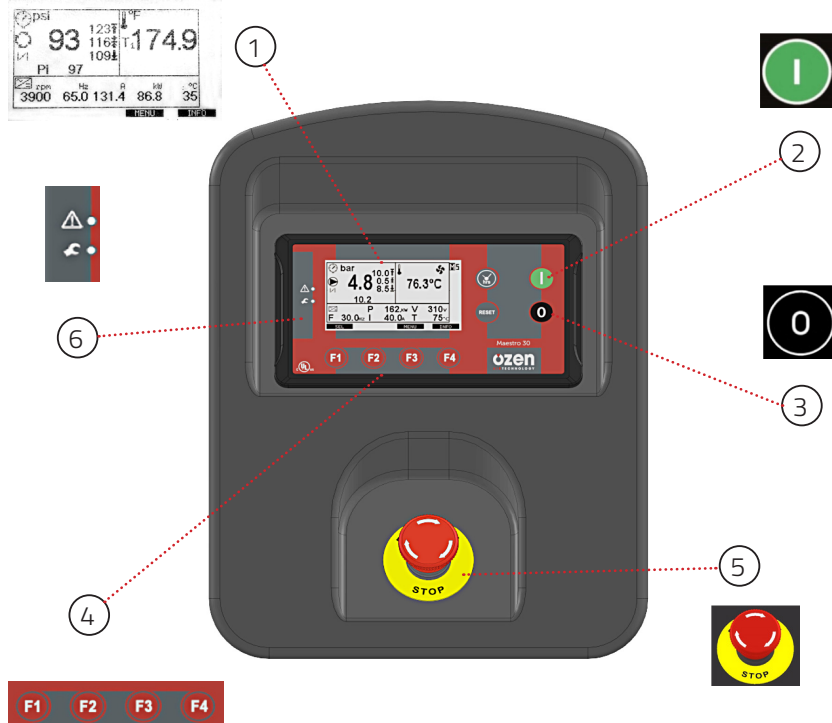

- 1 Digital Display: There are values (such as pressure in the air tank and temperature at screw oil outlet,) error codes in case of any faults, symbols (such as a fan symbol while the fan is running,) and text.
- 2 Start button: It is the button used to start the compressor.
- 3 Stop button: It is the button used to stop the compressor.
- 4 Menu keys: This is the in-menu navigation keys used when attempting to make any settings or when entering the menu for error codes.
- 5 Emergency stop: This is used to shut down the compressor immediately in case of any emergency encountered. Do not use this for normal stopping!
- 6 Compressor warning/alarm/malfunction LED (red color.)

3.2.4 ELECTRICAL CABINET

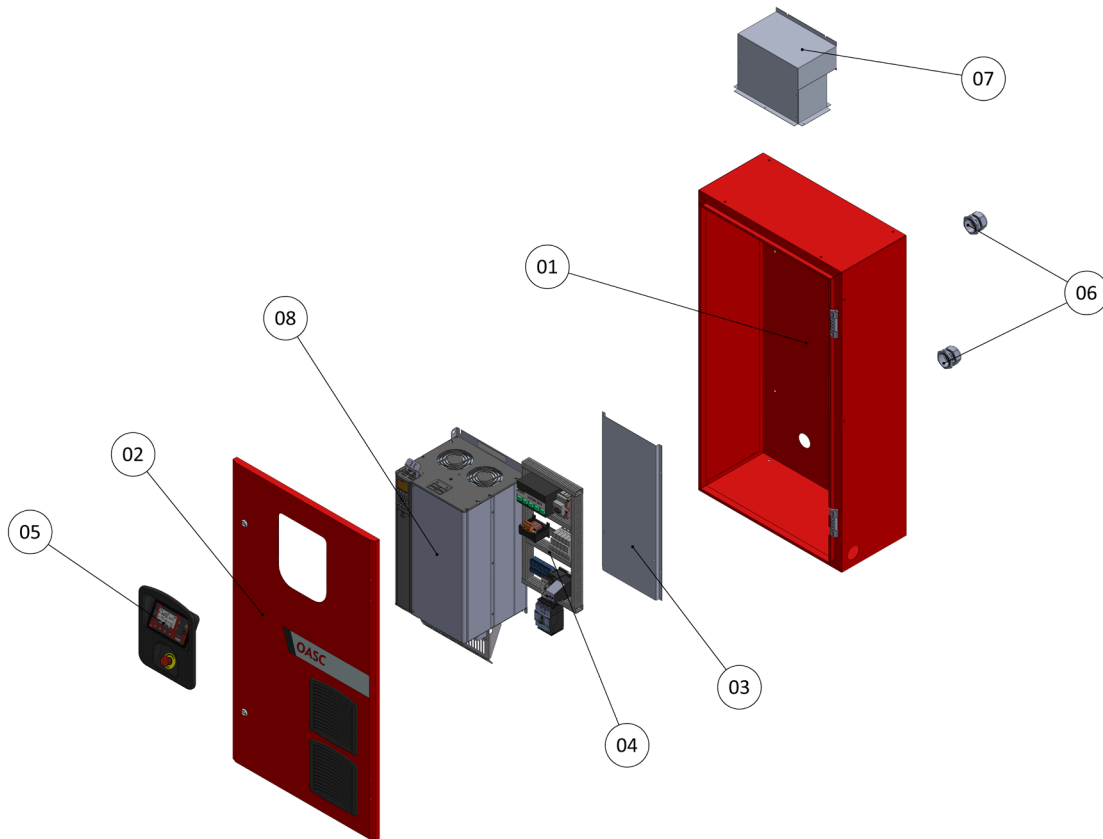

The control panel is located on the electrical cabinet door. The connecting cables of the motor enter through the cable gland at the back of the electrical cabinet.

The connecting cables for the incoming power enter the electrical cabinet through the cable gland on the bottom right side of the electrical cabinet.

NEMA 1 cabinets are used as standard. Contact your local Ozen Distributor for higher-level electrical cabinets.

01	Electrical cabinet
02	Electrical Cabinet Door
03	Electrical Back-Panel
04	Electrical Assembly
05	Control Panel
06	Cable Glands for Entry
07	Ventilation Hood
08	Inverter

THE SYSTEM OF COMPRESSOR

CHAPTER 3

Electric panel in detail:

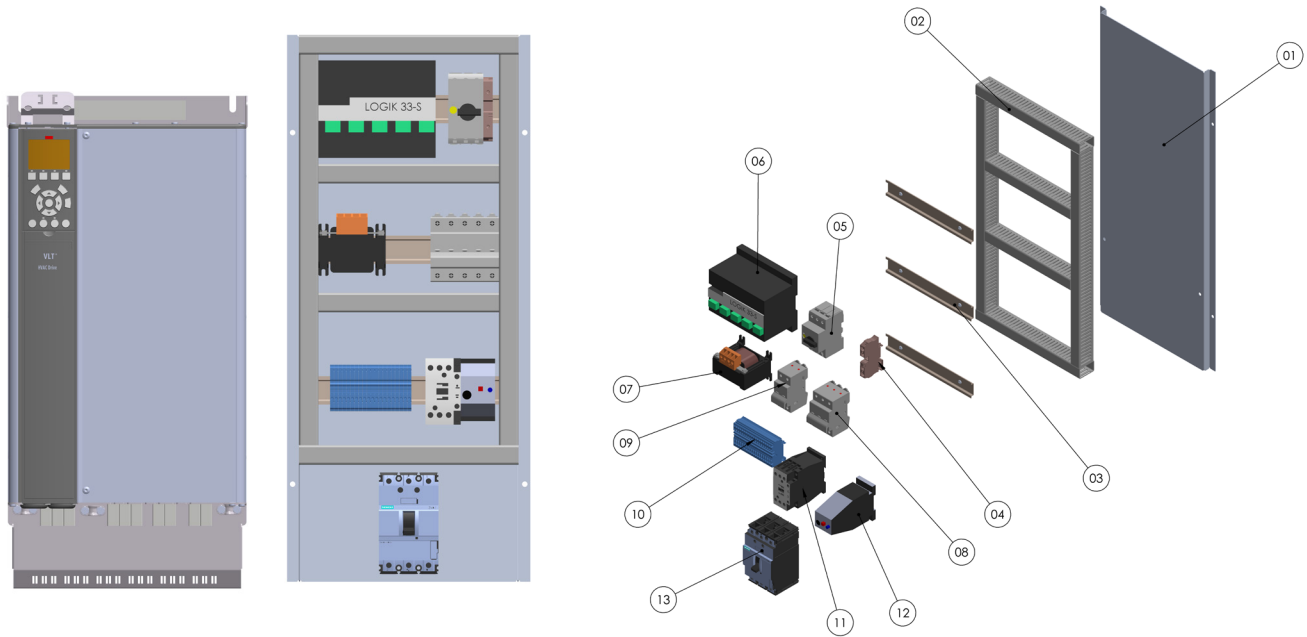

01	Electrical Back-Panel
02	Cable Tray
03	DIN Rail
04	Terminal Block for Power Group
05	Fan Switch
06	Control Unit
07	Transformer
08	Breaker group
09	Breaker group
10	Terminal Block for Control Group
11	Contactor for Dryer
12	Thermal Relay
13	Main Contactor

3.2.4.1 INVERTER

Pressurized air production represents the major part of energy costs. In fact, almost half of the electricity consumed by a company which produces pressurized air may be used by a compressor. Energy saving is becoming increasingly important for companies seeking increased efficiency.

Inverters used in screw compressors are known as frequency convertors. In order to realize a perfect regulation of the motor, the supply voltage should be proportionately changed with the supply voltage frequency.

Advantage of inverters:

- Provides energy savings of 35%, on average.
- Protects the compressor from problems which may arise from high/low voltage.
- Keeping the motor speed continuously under control ensures a consistent flow rate from the compressor.
- Keeping the motor properly under control extends the motor life.
- Losses in idle and slow running modes are eliminated.



THE SYSTEM OF COMPRESSOR

CHAPTER 3

3.2.5 COMPRESSOR CABINET

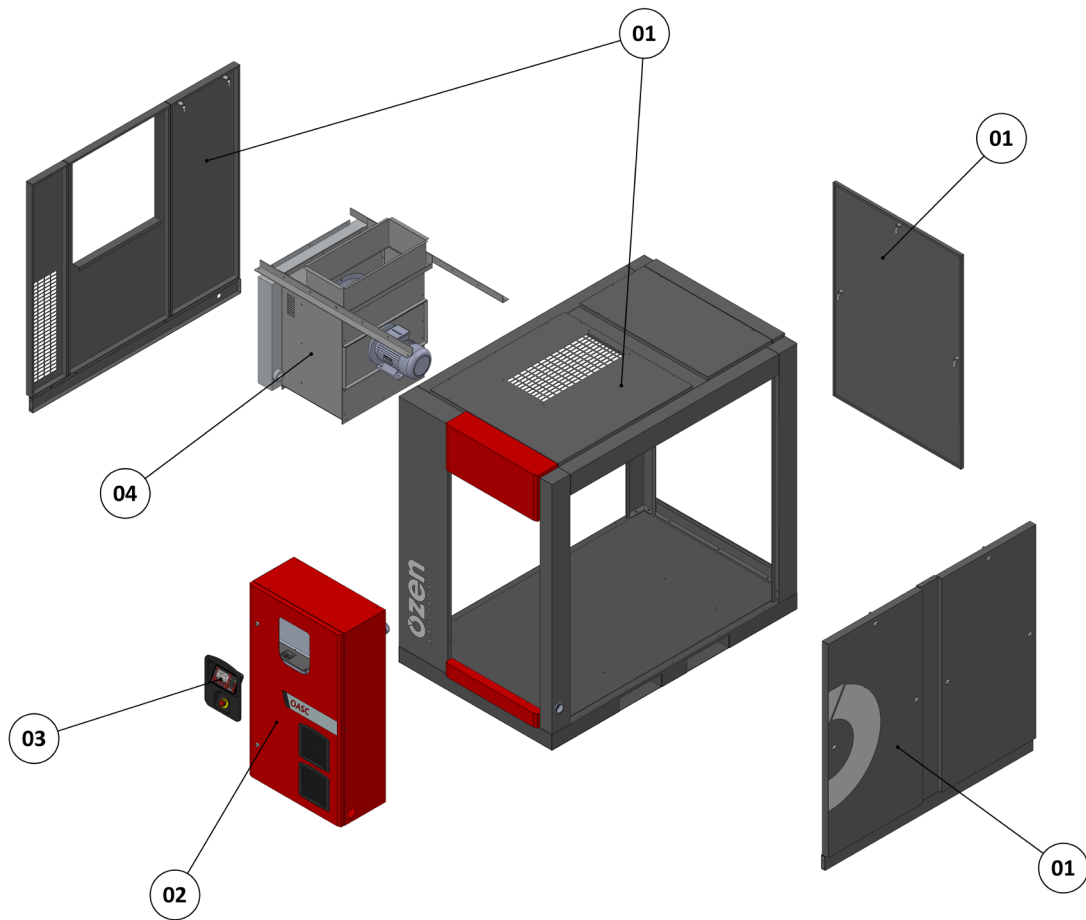

01	Compressor Cabinet
02	Electrical Cabinet
03	Maestro Controller
04	Compressor Cooling System

The compressor cabinet is produced by cutting and bending steel sheets of different thicknesses.

The cut and bent steel sheets are then brought together and assembled using bolts, nuts, and washers.

HOW IT OPERATES

CHAPTER 4

4.1 GETTING STARTED



ATTENTION!

Before operating the compressor:

- Ensure that all cable connections are correct and properly tightened.
- Ensure that no foreign material was left in the machine or electrical cabinet.
- Ensure that ground connections were made and are tight.
- Ensure that piping connections are made and tight, including the installation of a discharge isolation valve and drip leg.
- Check the oil level.
- Verify that the belt guard is in place and all bolts are tight.
- Check compressor for oil leaks.

To start the compressor:

- ▶ Verify that the emergency stop button is not engaged. To do this, rotate the red button clockwise. If it was engaged, the button will pop up.
- ▶ Press the start button on the control panel.
- ▶ At this stage, do not forget to check motor rotation direction as per Section 2.5.3.
- ▶ If the compressor does not start, check the screen on the controller. It will show the reason for the failure to start by displaying an error code.
- ▶ If an error code is displayed, you can see the cause of the error in Section 4.2 Control Panel.



ATTENTION!

Never operate the compressor without the panels in place and guards installed.





Make sure that all covers are closed before operating the compressor!

Ensure that the emergency stop button has been reset.

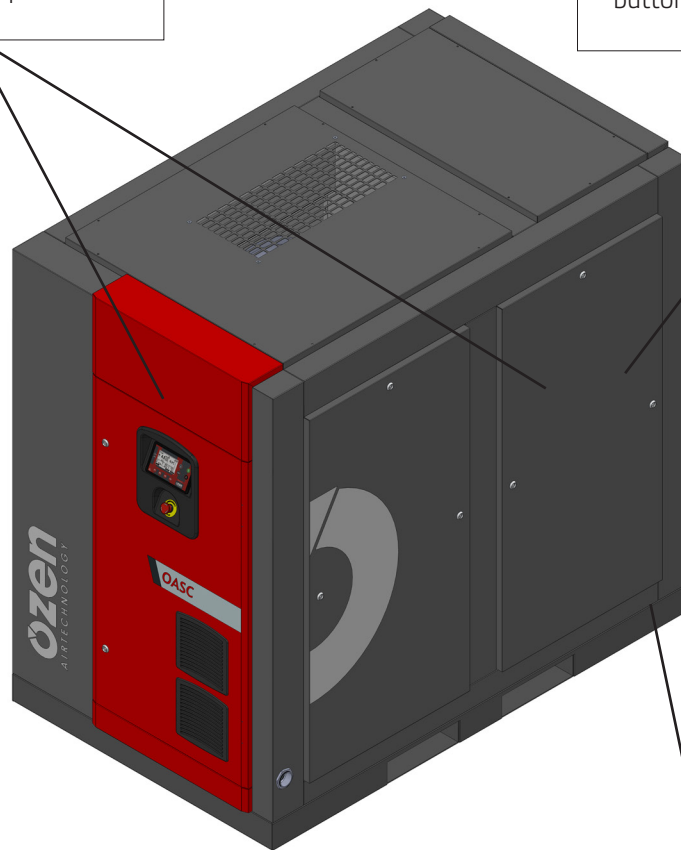

Operation of the compressor is controlled by a Maestro 30 control panel.

The Maestro 30 control panel is a PLC based control unit, which is specially designed for the compressor industry.

Verify that the electrical cables are of the proper size and secured properly to the gland.

HOW IT OPERATES

CHAPTER 4

4.2 CONTROL PANEL



> MAESTRO 30

An overview of the appearance of the Maestro 30 control panel exterior is given in Section 3.2.3

The Maestro 30 control panel is exclusively produced for Ozen Air Technology and is designed for easy control of the compressor. The Maestro 30, which is generally mentioned in Section 3.2.3. OPERATOR PANEL, will be described in detail in this section.

The Maestro 30 control panel:

- Controls the compressor.
- Shows the ideal service intervals for the compressor.
- Protects the compressor.

The Maestro 30 controller, along with the the sensors, overloads, etc., within the compressor, provides protections for the compressor. It will stop the compressor if an unsafe condition is sensed and will notify the user of the problem by displaying an error code. Never defeat any safety measures provided with this compressor and/or controller.

Alarms will stop the compressor, warnings will not. Always investigate the cause of alarms before attempting to re-start the compressor. Always obey warnings and take measures to clear them as soon as possible. Please notify your local Ozen Distributor to schedule service when you see a maintenance warning on your Maestro 30 controller.

4.2.1 MAESTRO 30 CONTROL PANEL DISPLAY

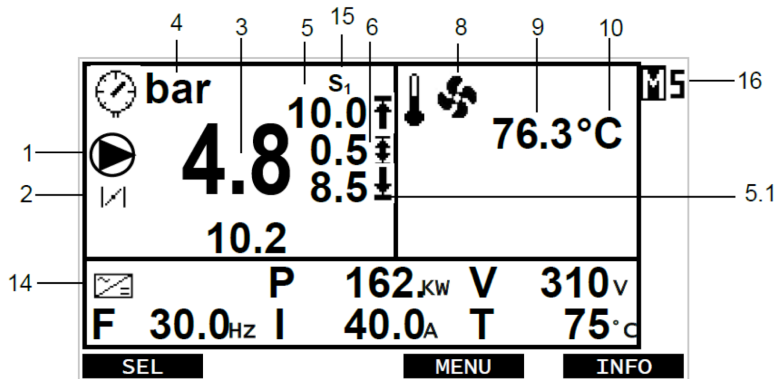

MEANING OF ICONS

1. Compressor ON (blinking if the compressor is going to stop or run. It's not visualized if the compressor is OFF.)
2. Load solenoid valve open.
3. Line pressure. (PSI / bar)
4. Units of the pressures. (PSI / bar)
5. Stop pressure. (PSI / bar)
- 5.1 Start pressure. (PSI / bar)
6. Pressure differential. (PSI / bar)
7. Detection of the pressure by the auxiliary pressure transducer: in the example above configured as absolute pressure.
8. Fan ON.
9. Air-end discharge temperature.
10. Units of the temperatures. (°F / °C)
11. Detection of the temperature by the auxiliary temperature probe: in the example above configured as differential temperature
13. Start – stop by timer
14. Data from the inverter (as indicated by the icon) for serial connection only: (F) working frequency, (P) power, (V) motor voltage, (I) motor amp draw and (T) temperature of the inverter's heat sink.
15. Level of pressure band the compressor is working.
16. Master/Slave operation enabled. Letters relating to the current operation of the compressor is shown in reverse: Letter in white on a black background.

HOW IT OPERATES

CHAPTER 4

4.2.2 MAESTRO 30 CODES AND DESCRIPTIONS OF ALARMS

ALARMS THAT DIRECTLY SHUT OFF THE COMPRESSOR

CODE	DESCRIPTION	CAUSE	ACTION
1	EMERGENCY STOP	Emergency stop button open (IN 1.)	Release emergency stop button.
2	THERMAL MOTOR	Thermal motor overload open (IN 2.)	Motor thermal overload relay (1E4) malfunction or high motor current present. Contact your local Ozen Distributor.
3	THERMAL FAN	Thermal fan motor overload open (IN 3.)	Fan motor thermal overload relay (4E4) malfunction or high fan motor current present. Contact your local Ozen Distributor.
8	HIGH PRESSURE	Working pressure over set WP2.	Contact your local Ozen Distributor.
9	TEMP. PROBE FAILURE	Air end temperature probe failure.	Contact your local Ozen Distributor.
10	HIGH TEMPERATURE	Air-end temperature over set WT1.	Contact your local Ozen Distributor.
11	LOW TEMPERATURE	Air end temperature lower than set WT5.	Increase the ambient temperature. If this does not remedy problem, contact your local Ozen Distributor.
12	POWER OFF	Signalled on power up in case of power off while compressor was on and selected as manual restart.	Check the electric cable connections. If this does not remedy problem, contact your local Ozen Distributor.
14	LOW VOLTAGE	Power supply to the controller lower than 9V (-40%); reset accepted only when power over 10.5V (-30%).	Check the control voltage. Reset if the voltage is over 10.5 V

Table-3

ALARMS THAT SHUT OFF THE COMPRESSOR AFTER 30 SECONDS

CODE	DESCRIPTION	CAUSE	ACTION
20*	SEPARATOR FILTER	Differential pressure switch separator filter open (IN6.)	Separator filters blocked. Replace separator elements. If this does not remedy problem, contact your local Ozen Distributor.
21	MOTOR TEMPERATURE	PTC input open.	Motor over temperature. Contact your local Ozen Distributor.
22	PRESS. TRANSD. FAILURE	Working pressure transducer failure.	Contact your local Ozen Distributor.
24	SAFETY	Timer CAF elapsed. Alarm detected only if the parameter SAFETY is set YES.	Contact your local Ozen Distributor.
80	DRIVE SHUT OFF	Drive shut off (shut off from serial communication and/or IN10 open): follow the drive alarm history in case of serial connection.	Contact your local Ozen Distributor.
81	DRIVE ALARM	Non shut off alarm on drive (from serial connection.) Follow the drive alarm history, if available.	Contact your local Ozen Distributor.
83	DRIVE COMMUNICATION	No communication to the drive. Check wiring and serial setting on the drive.	Contact your local Ozen Distributor.

Table-3

HOW IT OPERATES

CHAPTER 4

WARNINGS

CODE	DESCRIPTION	CAUSE	ACTION
30	DATA LOST	Default data are loaded on the controller (on power up check the data checksum in EPROM)	Contact your local Ozen Distributor.
32	TEMPERATURE WARNING	Temperature over set WT2. Automatic reset when temperature is below WT2 -5°C	Contact your local Ozen Distributor.
33	LOW VOLTAGE WARNING	Power supply to the controller below 10.5V (-30%) Automatic reset when the power rises over 12V (-20%)	Contact your local Ozen Distributor.
34	HIGH VOLTAGE	Power supply to the controller over 20.3V (+35%) Automatic reset when the power goes below 19.3V (+30%)	Contact your local Ozen Distributor.
37	MULTIUNIT FAILURE	No communication or master failure. Each slave works independently.	Contact your local Ozen Distributor.
65	CLOCK FAILURE	Start and stop of the compressor have to be operated manually. The Master/Slave operation timer is controlled by the micro controller.	Contact your local Ozen Distributor.
72	SEP. FILTER WARNING	Delta P. over set SP3. Automatic reset when delta P < SP3 - 2.9 psi and auxiliary transducer enabled (S08=1.)	Contact your local Ozen Distributor.
74	DLS/SUMMER TIME	In case of time setting on power up or time change (at 2:00 am in the morning on the last Sunday of March and October)	Contact your local Ozen Distributor.

Table-3

4.2.3 MAESTRO 30 MAINTENANCE CODES

It is possible to reset the maintenance error codes while the compressor is running. You can reset the error code that appears on the display by pressing the ENTER key on the Maestro 30 control panel.

When you see the maintenance error codes on the Maestro 30 screen, contact your local Oazen Distributor. Fulfillment of compressor maintenance on the scheduled time is very important for the service life of the compressor and it should be fulfilled without exceeding the maintenance time.

CODE	DESCRIPTION	ACTION
S-A	Service Plan A	See. 5. CHAPTER / 5.1.4 COMPRESSOR MAINTENANCE PERIODS
S-B	Service Plan B	See. 5. CHAPTER / 5.1.4 COMPRESSOR MAINTENANCE PERIODS
S-C	Service Plan C	See. 5. CHAPTER / 5.1.4 COMPRESSOR MAINTENANCE PERIODS
S-D	Service Plan D	See. 5. CHAPTER / 5.1.4 COMPRESSOR MAINTENANCE PERIODS

Table-4

HOW IT OPERATES

CHAPTER 4

4.2.4 MAESTRO 30 DESCRIPTION OF STATUS IMAGES ON THE HOME SCREEN

POWER ON



The following image becomes active on the Maestro 30 home screen when the power is ON.

START THE COMPRESSOR



To start the compressor: To operate the compressor from the OFF position, you must press the Maestro 30 start button.



From this point, the home screen of the Maestro 30 will switch to the following display. (The pressure value is for visual purposes only. The compressor pressure value and the display may be different on your compressor.)



ATTENTION!

Do not operate the compressor with any cabinet panels removed.

STOP THE COMPRESSOR

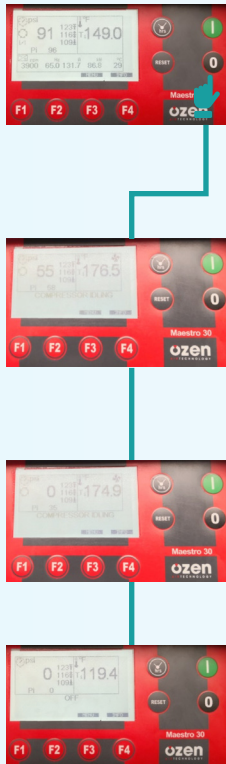

To Stop Compressor: When you press the stop button, the compressor will shut down. If the compressor is loaded at the time the stop button is pressed, it will unload. There are unload and safety timers involved, so the time that the compressor runs after pressing the stop button will vary, based upon the times set points of these timers (which are password protected.)

By default, the compressor will run unloaded for between 10 and 130 seconds, dependent upon the timers being satisfied and their set points. If the compressor is unloaded when the stop button is pressed, the compressor will continue to run unloaded until the timers are satisfied.

HOW IT OPERATES

CHAPTER 4

4.2.5 CONTROL PANEL USER SETTINGS

The Maestro 30 control panel is adjusted according to the user before the compressor leaves the Ozen factory.

The settings part of the Maestro 30 control panel is password-protected, which are only known to Ozen Technical Staff and Service Personnel. Entry of incorrect settings can present dangers to both personnel and equipment by disabling safety devices and allowing higher than rated pressures. This is why passwords are not provided to the user. The settings that the user can see and change are limited.

USER HOME SCREEN OF MAESTRO 30

When the compressor gives an alarm, you will see the alarm code on the screen. Reference the Codes and Descriptions of Alarms in section 4.2 Control Panel for more information on the alarm, as well as some helpful guidance on troubleshooting.

USER RESTRICTED SETTINGS

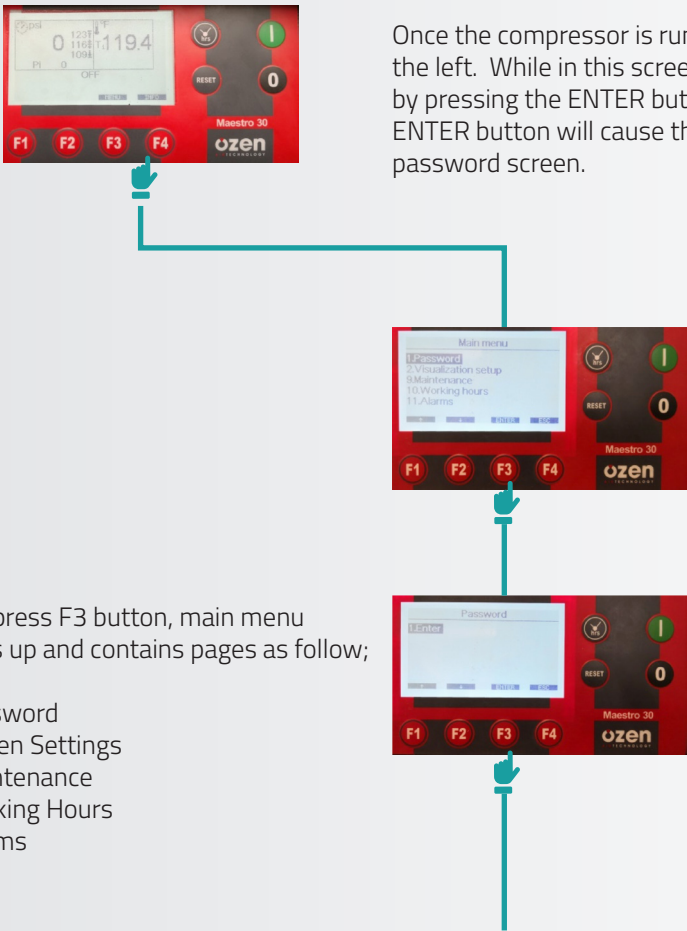

Once the compressor is running, you will see the screen to the left. While in this screen, you can enter the main menu by pressing the ENTER button. Pressing and holding the ENTER button will cause the Maestro 30 to enter the password screen.

Even though you can enter the password page by pressing the F3 button, you cannot enter the levels that are located on password page.

This screen allows entry of a password. There are a total of 3 different password screens. For equipment and personal safety, these passwords are reserved only for authorized Ozen Technicians and Distributors.

After press F3 button, main menu comes up and contains pages as follow;

- Password
- Screen Settings
- Maintenance
- Working Hours
- Alarms

USER RESTRICTED SETTINGS

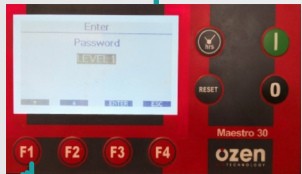

**LEVEL 1
NO ENTRY!**

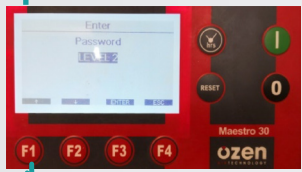

**LEVEL 2
NO ENTRY!**

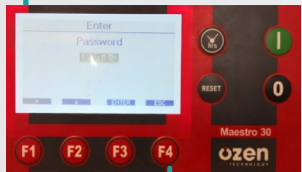

**LEVEL 3
NO ENTRY!**



HOW IT OPERATES

CHAPTER 4

4.2.6 CONTROL PANEL OPERATION SETTINGS

HOME SCREEN

The main menu of Maestro 30 control panel is explained below:



You can navigate through the menu via the F3 button. After entering the main menu by pressing the F3 button, the screen changes to below. In order to reach other options in menu, use the F1 and F2 buttons.

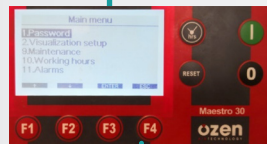

01-Information Menu: General information of compressor will be shown in this menu.

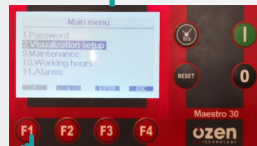

02-Screen Settings Menu

- Language of Control Panel
- Pressure and Temperature Units
- Screen Brightness
- Time and Date
- Daylight Saving Time

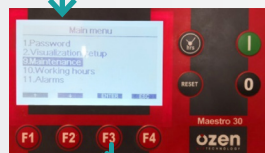

09- Maintenance Menu:

Maintenance periods and history can be found in this menu.

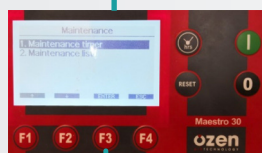

PRESSURE SETTINGS

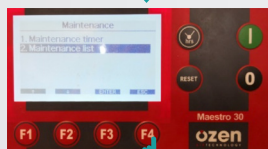

09-Maintenance Menu

- CAF > Air Filter Change Time
- COF > Oil Filter Change Time
- CSF > Separator Filter Change Time
- C-- > Oil Change Time
- C--h > Compressor Control Time
- BL > Bearing Control and Lubrication Time

10-Working Hour Menu

- Total Working Hour
- Working Hour on Load
- Working Percentage on Load
- Number of Start per Hour
- Flow
- Average Consumption

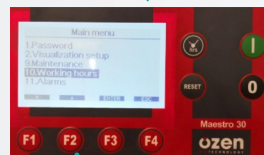
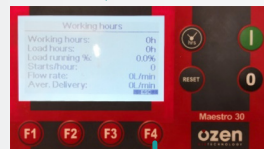
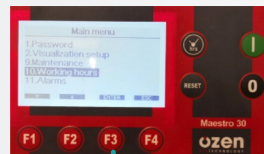

11- Alarm Menu:

The alarms can be found in this menu with details: hour, date and error code.

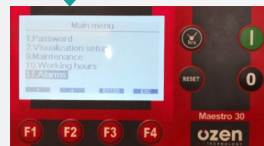

HOW IT OPERATES

CHAPTER 4

Use of the HRS and F4 buttons:



Pressing the F4 button shows time, date and software version of Maestro 30.



When HRS button is pressed, working hours of compressor can be found. This is a shortcut of the user menu.

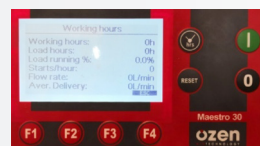

PRESSURE SETTINGS

4.3 DAILY OPERATING INSTRUCTIONS

It is important to perform the daily checks on your compressor. This can prevent costly down-time of your system by uncovering potential issues before they become a problem.

Before operating your compressor;

- ▶ Check the amount of oil in the separator tank.

In the instance of low oil level, fill the compressor with the appropriate Ozen oil, following all safety precautions.

After starting the compressor:

- ▶ Make sure that there are no error codes on the control panel display.
- ▶ Check the pressure and temperature values on the control panel.
- ▶ Check for leaks and proper operation by observing the operation of the compressor for several minutes.
- ▶ Do not remove any components while the compressor is in operation.



ATTENTION!

When performing any operation on the compressor, stop the compressor and ensure that any residual air pressure has been relieved. Perform proper lock-out/tag-out procedure, wearing any required PPE per regulations. Always adhere to any local and national laws and safety regulations.



ATTENTION!

Do not operate the compressor with any cabinet panels removed.

MAINTENANCE

CHAPTER 5

5.1 PREVENTIVE MAINTENANCE INTERVALS

5.1.1 GENERAL DESCRIPTION

- ▶ The compressor maintenance and repairs must be carried out as described in this manual.
- ▶ Genuine Ozen parts must be used for maintenance and repairs.
- ▶ Appropriate and correct tools and implements should be used for maintenance and repairs.
- ▶ Disconnect the compressor from the power supply and always follow required lock-out/tag-out procedures and wear appropriate personal protective equipment (PPE) when performing any troubleshooting, maintenance, and/or repairs of the compressor. Always follow every safety precaution.
- ▶ Isolate the compressor from the pressure line by closing the compressor's air discharge valve and check that the compressor has an internal pressure of 0 Psi (no pressure) on the display of the Maestro 30 control panel.
- ▶ Do not clean with any flammable solvents or ones that leave any type of residue. Cleaning should be performed with a soft, lint-free cloth and mild cleaners.
- ▶ Care should be taken to avoid leaving loose bolts, nuts and glands in the compressor after maintenance and repair. Equipment used in maintenance and repair of the compressor (screwdriver, etc.) should not be forgotten inside the compressor.
- ▶ Before performing any type of service work, you must thoroughly read and understand this manual. Failure to do so may result in voiding the warranty, personal injury, and/or equipment damage.
- ▶ For cases in which there are any issues that you cannot solve, please contact your nearest Ozen Distributor.



ATTENTION!

Maintenance of the compressor by unauthorized personnel or improperly trained personnel will void any warranty and may also result in equipment damage and/or personal injury



5.1.2 DAILY MAINTENANCE

- ▶ Check the oil level daily.
- ▶ If the oil level is below 1/2 in the sight glass when the machine is off, add oil to bring it up to 1/2 in the sight glass before running the machine.
- ▶ If oil loss is frequent, there is likely a problem with the compressor. Refer to the Faults and Solutions chapter for possible causes and solutions. Contact your local Ozen Distributor for service or repair.
- ▶ In the case of air leakage, the efficiency of the compressor will decrease and the noise level will increase. Contact your local Ozen Distributor for service or repair.
- ▶ Check daily to ensure that there are no warnings and/or errors on the controller.
- ▶ Perform a visual check of the compressor for proper operation daily.
- ▶ Do not remove any components of the compressor while it is running. Always stop the compressor, relieve pressure, and observe proper safety precautions before making any adjustments while performing the daily checks.



5.1.3 WEEKLY MAINTENANCE

- ▶ Clean the air filter element with compressed air. Do not use any type of cleaning solvents.
- ▶ You should clean the cooler fins with compressed air.
- ▶ You should check the oil level.
- ▶ You should empty water accumulated in the air tank.
- ▶ Visually inspect the hoses for air and oil leaks.



MAINTENANCE

CHAPTER 5

5.1.4 COMPRESSOR MAINTENANCE INTERVALS

The maintenance intervals of the compressor are as shown in the table below.

Maintenance Intervals	Working Hours												Section
	2000	4000	6000	8000	10000	12000	14000	16000	18000	20000	22000	24000	
Air Filter Replacement	✓	✓	✓	✓	✓	✓	✓	✓	✓	✓	✓	✓	5.1.4.4
Oil Filter Replacement	✓	✓	✓	✓	✓	✓	✓	✓	✓	✓	✓	✓	5.1.4.3
Cooler Cleaning	✓	✓	✓	✓	✓	✓	✓	✓	✓	✓	✓	✓	5.1.4.10
Coupling Check	✓	✓	✓	✓	✓	✓	✓	✓	✓	✓	✓	✓	5.1.4.9
Electrical Connection Check	✓	✓	✓	✓	✓	✓	✓	✓	✓	✓	✓	✓	2.4
Oil / Air Leakage Check	✓	✓	✓	✓	✓	✓	✓	✓	✓	✓	✓	✓	5.1.2
Separator Replacement		✓		✓		✓		✓		✓		✓	5.1.4.3
Replacement of Cabinet Filters		✓		✓		✓		✓		✓		✓	5.1.4.12
Oil Plug O-Ring Replacement				✓				✓				✓	5.1.4.2
Oil Change				✓				✓				✓	5.1.4.2
Thermostatic Valve Maintenance Kit Replacement				✓				✓				✓	5.1.4.7
Air intake valve Maintenance Kit Replacement				✓				✓				✓	5.1.4.8
Minimum Pressure Valve Maintenance Kit Replacement				✓				✓				✓	5.1.4.6
Oil Temperature Sensor Replacement												✓	5.1.4.11
Coupling Replacement												✓	5.1.4.9
Air-end and Motor Bearings Seal Rebuild												✓	5.1.4.1
Solenoid Valve Diaphragm Replacement												✓	5.1.4.8
Hose Replacement												✓	5.1.4.12
Service Plan Code	S-A	S-B	S-A	S-C	S-A	S-B	S-A	S-C	S-A	S-B	S-A	S-D	4.2.3

Table-5

The control panel alarm will display at each 2000 hour period for scheduled maintenance. This maintenance needs to be performed to maintain warranty and longevity of the life of the compressor. Please contact with your local Ozen Distributor for Ozen genuine service kits and parts.

5.1.4.1 AIR-END AND MOTOR

It is recommended that electric motor and air-end rebuilds should be carried out when they complete 24000 working hours. The front and rear bearings are replaced during the motor rebuild.

All bearings, seals and bearing houses are replaced during the air-end rebuild. At the same time, rotors should be checked to determine if there is any wear or not and, if required, subject to rebuild.



5.1.4.2 OIL SPECIFICATIONS, CHECK AND REPLACEMENT

Defined oil replacement intervals are valid for standard operating conditions and nominal operating pressure.

Exposure of the compressor to external pollutants, operation at high temperature, and/or operation with low duty cycles may dictate a shorter time interval between oil changes. Contact your local Ozen Distributor for a more personalized estimate based upon your site conditions and machine operation.

ZenLube Grades	46	68
Viscosity cSt @ 40°C	45	64
Viscosity cSt @ 100°C	6.5	8.57
Flash Point °F (°C)	445 (229)	451 (233)
Demulsibility, 130 °F, 30 Min	40/40/0	40/40/0
Copper Corrosion, 24 Hr	1a	1a
Rust Test: Distilled Water	Pass	Pass
Rust Test: Salt Water	Pass	Pass
Foam Sequence I, II, III	0/0/0	0/0/0

Table-6

ZenLube Troya Grades	46	68
Viscosity cSt @ 40°C	46.1	67
Viscosity cSt @ 100°C	6.7	8.7
Flash Point °F (°C)	450 (232)	478 (248)
Copper Corrosion	1a	1a
Rust Test: Distilled Water	Pass	Pass
Rust Test: Salt Water	Pass	Pass
Foam Sequence I, II, III	0/0/0	0/0/0

Table-7

ZenLube Troya FG Grades	46	68
Viscosity Index	105	103
Viscosity cSt @ 40°C	47	71
Viscosity cSt @ 100°C	7.0	9.3
Flash Point °F (°C)	450 (232)	465 (241)
Copper Corrosion, 24 Hr	1a	1a
Rust Test: Distilled Water	Pass	Pass
Rust Test: Salt Water	Pass	Pass

Table-8

MAINTENANCE

CHAPTER 5

• Oil Level Check And Addition

The correct amount of oil is placed in the compressors before they are delivered to the customer. However, there may be a decrease in the oil amount during transportation and/or after a certain period of operation. Ensure the oil level is correct before start up.

- ▶ The oil level is checked by way of the oil level sight glass, which is located on the separator tank.
- ▶ The oil level must be at the mark provided in the middle of the oil level indicator when the machine is shut down and cooled down.
- ▶ The image showing the required oil level is below.



The required level of oil



ATTENTION!

The compressor must be stopped for a period of 10 minutes before checking the oil level.



• Oil Change And Addition



If a check of the oil level sight glass reveals no oil in the sight glass, then oil is required to be added to bring the level to half-way in the sight glass when the machine is shut down and cooled down.



The compressor oil must be changed at every 8000 working hours. whether the oil inside the separator tank is low or not. Every 8000 hours of operation, the compressor oil changes structurally and, if not replaced, the compressor's operating life is reduced. Compressors that are not serviced in accordance with the maintenance schedule will not be covered by warranty.

Before changing the compressor oil, the compressor must be stopped and the internal pressure in the separator tank must be completely evacuated. The oil drain plug under the separator tank is to be removed and the valve opened for the oil in the system to be drained.

MAINTENANCE

CHAPTER 5



After removing the oil drain plug, tighten the hose nozzle (supplied with the compressor) to the valve. Then attach the hose to the hose nozzle and connect it with the clamp.



After removing the oil drain plug, tighten the hose nozzle (supplied with the compressor) to the valve. Then attach the hose to the hose nozzle and connect it with the clamp.

- ▶ After the oil in the system has drained, the valve is closed and hose and the hose nozzle are removed. The drain plug is reinserted and tightened.
- ▶ The new oil is added by removing the oil fill plug on the separator tank.



- ▶ If there is an oil leak around the plug, the o-ring must be replaced.
- ▶ There is no need to replace the plug if there is a leak, just replace the o-ring.
- ▶ Filling can be completed with the use of a funnel.
- ▶ Refill the separator tank with the appropriate type of oil. If there is uncertainty as to what type of oil to use, please contact your local Ozen Distributor.
- ▶ After filling to the mark in the middle of the sight glass, the plug can be reinstalled and tightened.



IMPORTANT!

Do not ever mix different types of oil. Doing so will void any warranty. If oils are accidentally mixed, do not run the machine. Contact your local Ozen Distributor immediately. Genuine Ozen oils and parts **MUST** be used in order for the warranty to remain intact.

MAINTENANCE

CHAPTER 5

5.1.4.3 OIL FILTER AND SPIN-ON SEPARATOR REPLACEMENT

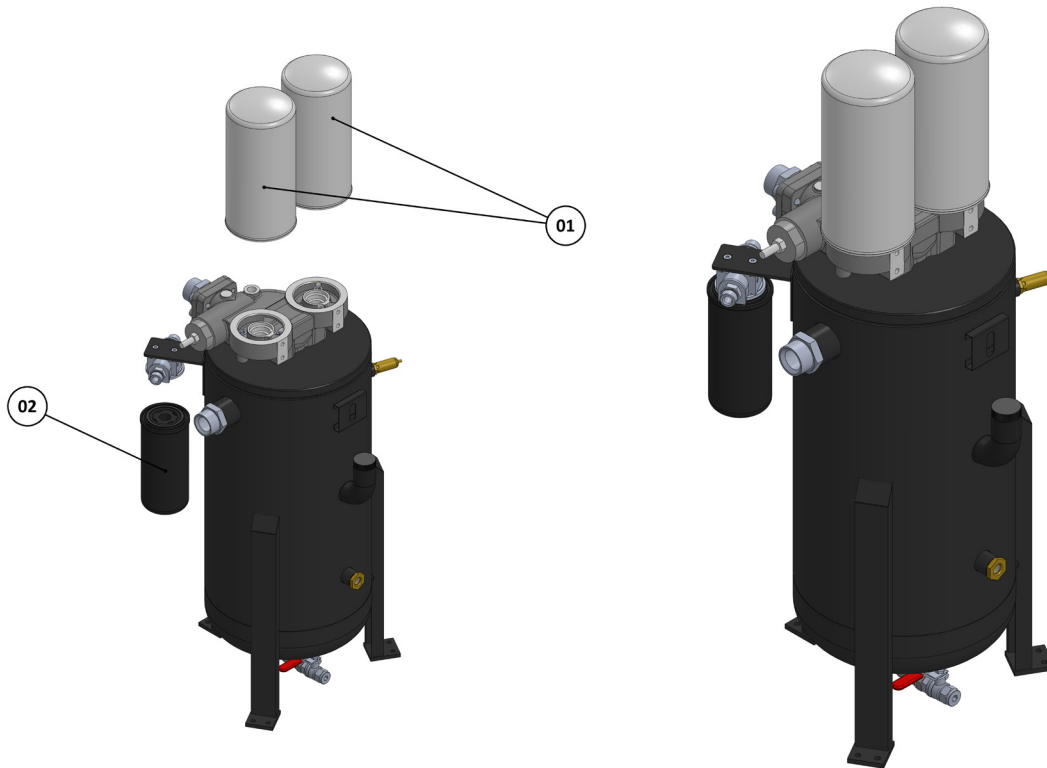

01 Spin-on Separator
02 Oil Filter

▪ Oil Filter Replacement



- ▶ You can see the oil change intervals in the “Oil specification check and replacement” section.
- ▶ After draining the oil, remove the oil filter by turning it counterclockwise with the help of strap-type filter wrench.
- ▶ There is no need to drain the oil if you are changing the oil filter.



- ▶ Clean the surface of any gasket residue remaining on the separator combination block after removing the used oil filter.
- ▶ Lubricate the surface of the seal on the new oil filter with new oil for easy installation.
- ▶ Tighten the new oil filter by hand until snug.

MAINTENANCE

CHAPTER 5

▪ Spin-on Separator Replacement



- ▶ Before changing the spin-on separator filter, stop the compressor and wait until the air in the system is completely drained.
- ▶ Remove the spin-on separator with the help of a strap-type wrench.



- ▶ Clean any remaining gasket material from the separator combination block.
- ▶ Lubricate the surfaces of the seal of the new spin-on separator.
- ▶ Manually tighten the new spin-on separator clockwise until snug.
- ▶ Never attempt to clean the spin-on separator. Always replace the separator with a new one.

5.1.4.4 CLEANING AND REPLACEMENT OF AIR INTAKE FILTER

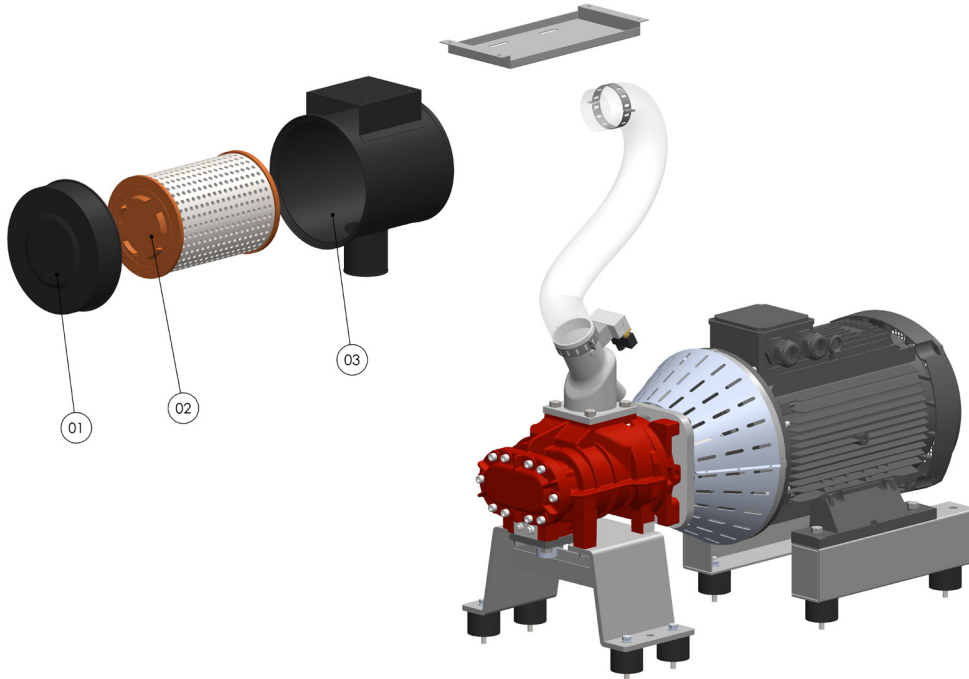

01	Air Intake Filter Housing
02	Air Intake Element
03	Air Intake Filter Housing

- ▶ Ensure that the compressor is completely switched off when replacing the air filter.
- ▶ Replacement of the air filter is important for more efficient operation of the compressor.
- ▶ The air filter may need to be replaced if the compressor fails to receive sufficient air.
- ▶ Contact your local Ozen distributor when the air filter needs replacing.

MAINTENANCE

CHAPTER 5

5.1.4.5 INSPECTION AND REPLACEMENT OF SAFETY VALVE

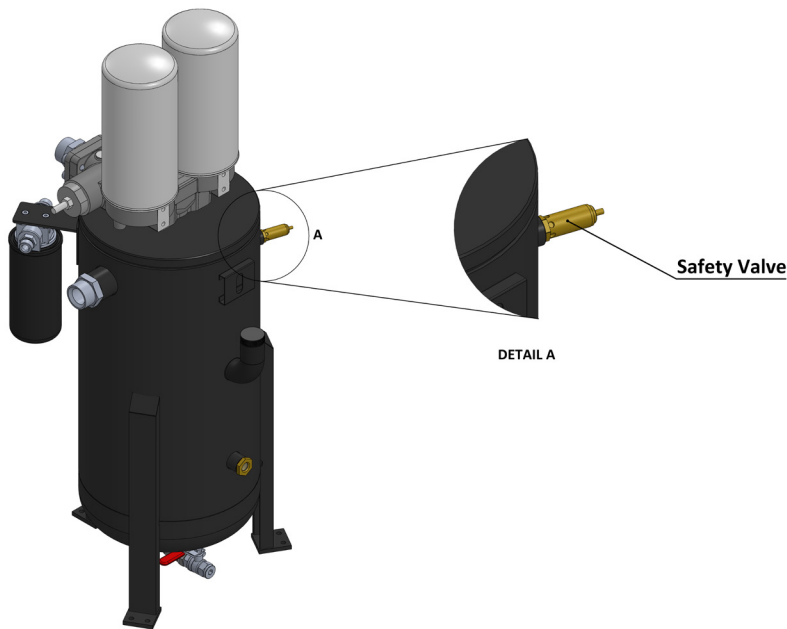

The safety valve is located/mounted on the separator tank of the compressor.

The presence of air and oil leaks generally means that the safety valve is defective.

The safety valve is not serviceable. If there is a malfunction, the valve must be replaced.

Replace the defective safety valve with a new one rated at the same specifications.

Faults that may be caused by the safety valve are outlined in "CHAPTER 6 / FAILURE AND SOLUTIONS".

5.1.4.6 REPLACEMENT OF MINIMUM PRESSURE VALVE

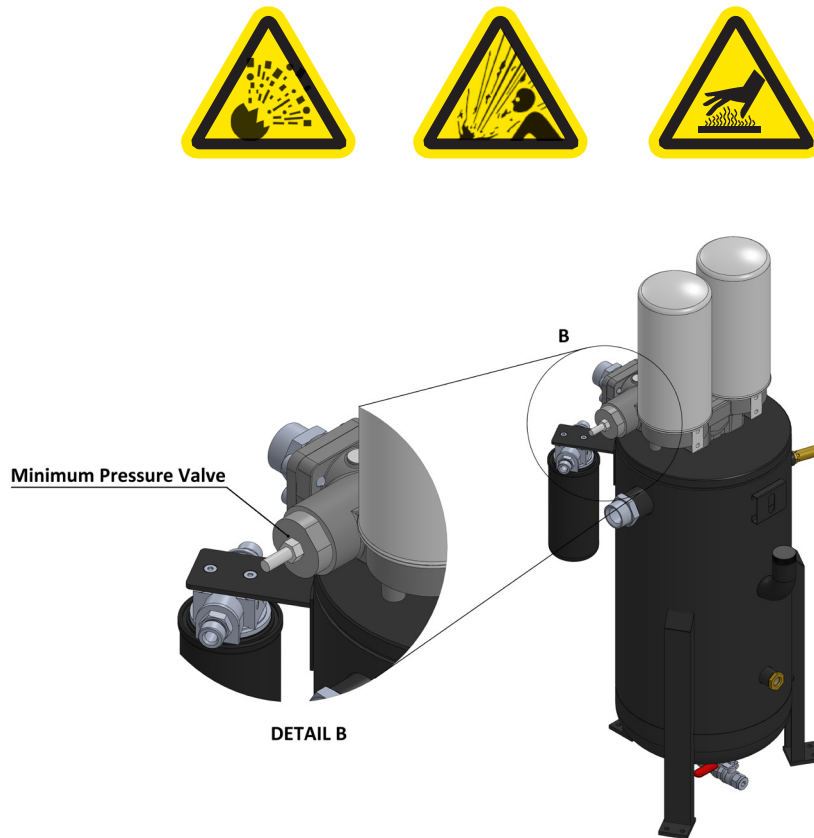

The minimum pressure valve is mounted inside the separator combination block.

The minimum pressure valve is set at 58 psi.

The minimum pressure valve can not be serviced. It should be replaced if there is any malfunction.

When replacing the minimum pressure valve, ensure that the machine is isolated and system pressure has been relieved.

Replace the defective minimum pressure valve with a new one rated at the same pressure.

Faults that may be caused by the minimum pressure valve are outlined in "CHAPTER 6 / FAILURES AND SOLUTIONS"

MAINTENANCE

CHAPTER 5

5.1.4.7 REPLACEMENT OF THERMOSTATIC VALVE

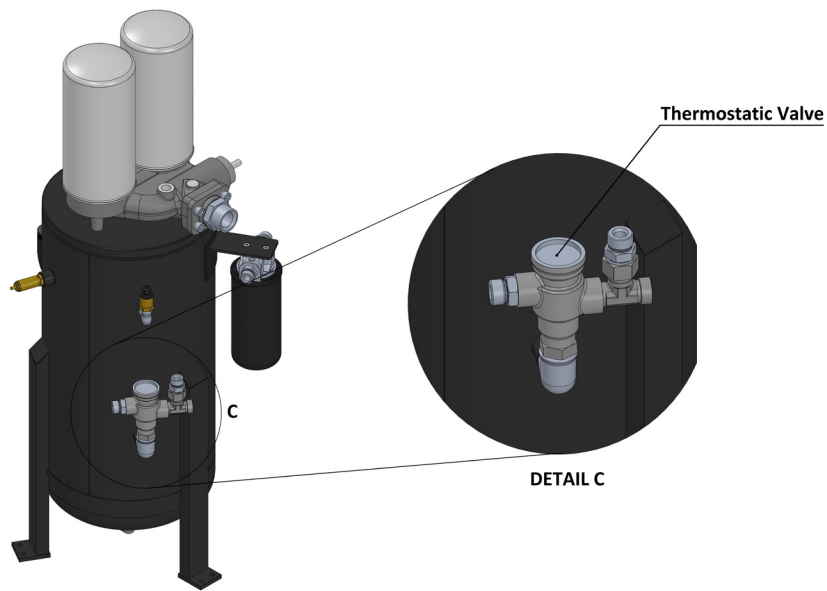

The thermostat is mounted on the outside of the separator tank in the compressor.

The thermostat is a closed circuit unit, which is set to 160° F (71° C).

The thermostat can not be repaired so It should be replaced if there is any malfunction.

Contact an authorized Ozen distributor when any high temperature warnings appear on the Maestro 30.

Faults that may be originating from the thermostat can be seen in the "CHAPTER 6 / FAILURES AND SOLUTIONS".

5.1.4.8 CHECK AND REPLACEMENT OF AIR INTAKE VALVE (SUCTION FLAP)

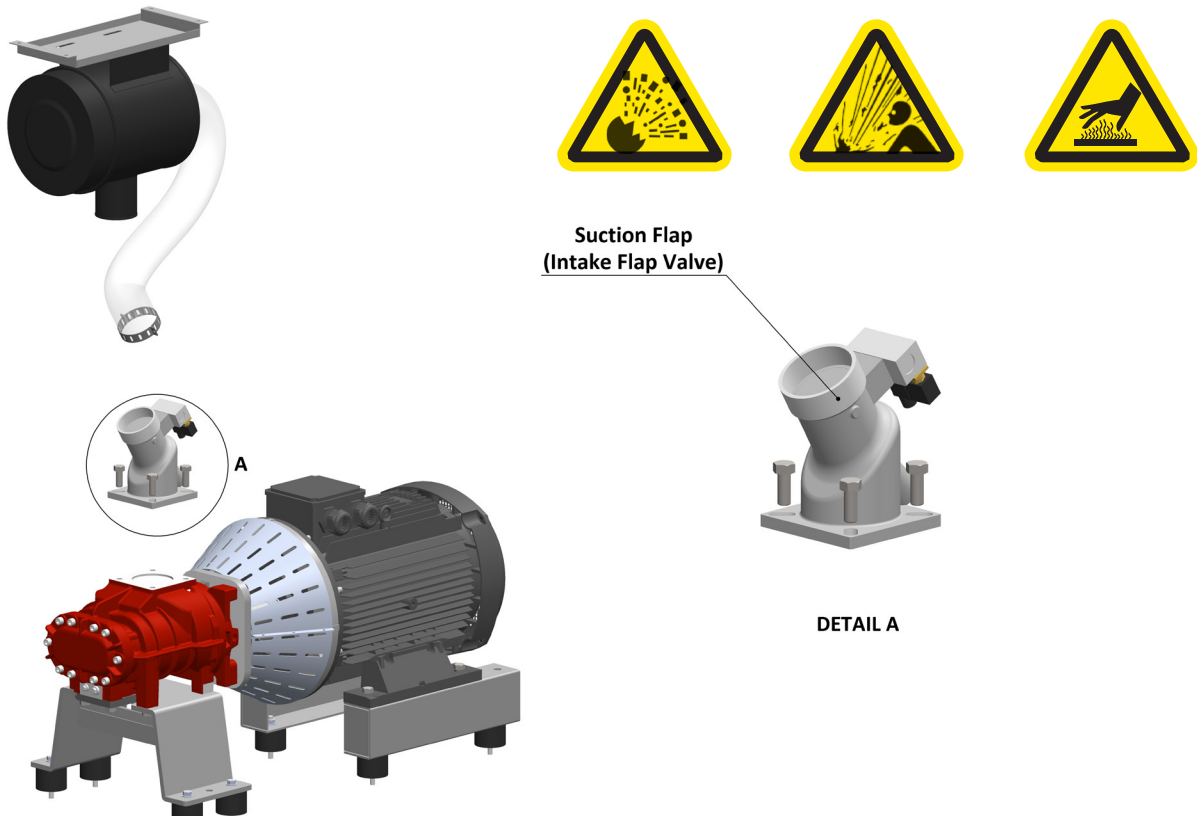

The inlet valve is located on the inlet port of the air-end and it is of a vertical design. The blow down solenoid is attached to the inlet valve and both valves are normally-open. The internal piston controls the amount of air allowed into the air-end for compression and it has an internal non-return valve to prevent back-flow of air and oil when the machine is stopped.

The solenoid blow-down valve releases the internal pressure on the compressor when it is stopped or faults out on alarm. Solenoid valves are replaced with new ones during the 24,000 hour maintenance service.

The wear and tear of the air intake valve components depends on compressor applications and operating parameters.

Before the replacement, make sure that the compressor is stopped and the internal pressure has dropped to 0 psi as observed on the Maestro 30 screen.

If the compressor does not reach the desired pressure and the internal pressure does not drop with the compressor not operating there could be an issue with the air intake valve..

Malfunctions that may be originating from the inlet valve can be seen in the "CHAPTER 6 / FAILURES AND SOLUTIONS".

Use of original spare parts kits mentioned in the maintenance and troubleshooting instructions of Ozen Air Technology are recommended during valve inspection and routine maintenance operations.

MAINTENANCE

CHAPTER 5

5.1.4.9 INSPECTION AND REPLACEMENT OF COUPLING



If abnormal sound comes from the electric motor, air-end, or inside of motor cover, it could mean that there is a problem with the coupling. In that case, please contact your local Ozen Distributor.

The coupling is serviced according to the maintenance chart or as recommended by an Ozen Service Professional.

In a direct coupled system, the coupling alignment is set and all required tests are implemented in our factory.

If spare parts are needed, please contact your local Ozen Distributor.

5.1.4.10 INSPECTION AND CLEANING COOLING GROUP



The cooler can become dirty and/or clogged over time.

Clogged or contaminated coolers cannot properly fulfill their cooling function and the oil and air temperatures will increase.

The cooler should be cleaned with compressed air once a week.

The cooler will also be checked and serviced during every maintenance service. The cooler will be replaced if necessary.



ATTENTION!

Do not hold the air gun close to the cooler when cleaning the cooler with compressed air. If held too close to the cooler, the fins will bend. This will reduce the efficiency of the cooler.

5.1.4.11 OIL TEMPERATURE SENSOR REPLACEMENT



The oil temperature sensor is located inside the brass fitting attached to the oil outlet of the airend.

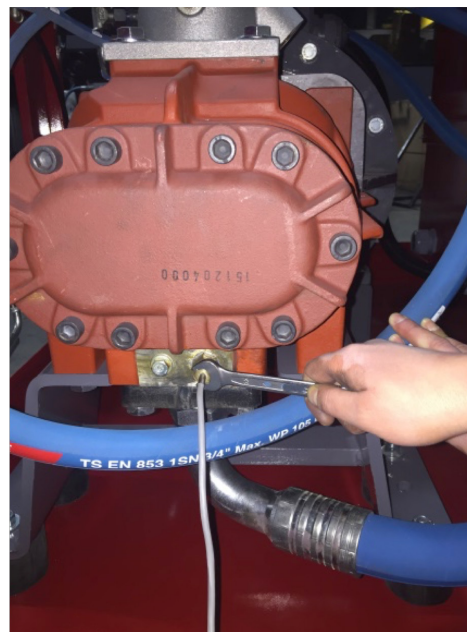

This temperature sensor loses its effectiveness over time and needs to be replaced.

When the oil temperature sensor is being replaced, the nut of the brass fitting is removed and the sensor is taken out and replaced.

The oil temperature sensor should be changed every 24,000 hours as shown in the compressor maintenance chart.

MAINTENANCE

CHAPTER 5

5.1.4.12 MAINTENANCE AND REPLACEMENT OF CABINET FILTERS AND HOSES

The cabinet filters serve an important role in the internal cooling of the compressor. The cabinet filters must be cleaned using compressed air at least once a week. The compressor will overheat if the cabinet filters are not maintained or if there is an air restriction. In addition to the cleaning of the cabinet filters, they should be inspected and replaced by an authorized Ozen distributor every 4000 hours per the maintenance schedule.

Hoses should be checked by the user every week by opening the side panels. Contact an authorized Ozen distributor if any leaks are found.

Hoses must be replaced at the 24,000 hour maintenance period.

Hose maintenance and replacement should be completed by an authorized Ozen distributor.

FAILURES AND SOLUTIONS

CHAPTER 6

FAILURE	POSSIBLE FAILURE CAUSES	SOLUTION
Compressor not starting	Power failure	Check the phase cables and tighten if loose.
	Tripping of main and control fuses	Contact your local Ozen Distributor
	A break in a cable or loose connections	Contact your local Ozen Distributor
	Tripping of thermal overload of motor or fan	Reset thermal fuse of motor or fan.
	Compressor stopped due to any malfunction	Contact your local Ozen Distributor
	Re-starting the compressor immediately after a short time	The evacuation of the internal pressure has not yet been completed. After a short time the compressor will be ready for use again.
It takes too long for the compressor to start	Y-D changeover is not properly set	Contact your local Ozen Distributor
	Low input voltage or fluctuating current	Check the electrical infrastructure at your facility and correct any faults.
	The ambient temperature is too low and the oil is too cold	Increase the ambient temperature
	High oil viscosity	Use the appropriate oil type in your compressor. Change the oil of the compressor if it is time to replace the oil.
	Defective air intake valve	Contact your local Ozen Distributor
	Defective motor	Contact your local Ozen Distributor
Compressor fails to reach the desired pressure value	Leakage in the air line	Check the air hoses and the connections.
	Defective air intake valve	Contact your local Ozen Distributor
	Clogged air filter	Contact your local Ozen Distributor
	Insufficient capacity of the compressor for your system	Contact your local Ozen Distributor
	Defective air-end	Contact your local Ozen Distributor
	Defective safety valve	Contact your local Ozen Distributor
	Improperly set motor thermal overload	Contact your local Ozen Distributor
	Improperly set pressure switch	Contact your local Ozen Distributor

Compressor exceeds the desired pressure value	Improperly set pressure values	Pressure values must be corrected via the control panel
	Defective pressure sensor	Contact your local Ozen Distributor
Compressor fails to generate compressed air	Defective air intake valve	Contact your local Ozen Distributor
	Y-D system changeover time is not properly set	Contact your local Ozen Distributor
	Defective minimum pressure valve	Contact your local Ozen Distributor
	Defective solenoid valve	Contact your local Ozen Distributor
Compressor stops due to tripping of the motor thermal overload	Defective Air-end	Contact your local Ozen Distributor
	Improper thermal overload setting	Check the motor thermal overload setting. Correct the setting, as necessary.
	High pressure setting value	Check the pressure on the control panel. Correct if it is high.
	Low input voltage	Check the voltage at the power supply input of the compressor.
	Problem with motor	Contact your local Ozen Distributor
	Too high operating ambient temperature	Maintain the ambient temperature of the compressor to between 32 °F (0 °C) and 115 °F (46 °C.)
Compressor is losing oil excessively	Leakage in oil connection line	Contact your local Ozen Distributor
	Faulty separator filter	The separator element is required to be replaced

FAILURES AND SOLUTIONS

CHAPTER 6

Compressor stops due to the tripping of the thermal overload of the fan	The thermal overload setting is improper	Check the cooling fan thermal overload setting on the panel. Correct the setting as necessary.
	Problem with hot air outlet	Make sure that there are no obstructions in the hot air outlet - clean the cooler fins if necessary
	Cooling fan motor problem	Contact your local Ozen Distributor
	Too high operating ambient temperature	Maintain the ambient temperature of the compressor to between 32 °F (0 °C) and 115 °F (46 °C.)
Contactor contacts are wearing too quickly	Y-D changeover time is too short	Contact your local Ozen Distributor
	Compressor is exposed to too frequent stop and restart operation.	Contact your local Ozen Distributor
	Low voltage at the input to the compressor	Check the electrical infrastructure of the facility.
	Use of improper parts	Contact your local Ozen Distributor
Temperature sensor or contact thermometer warning due to excessive temperature	System lacking oil	Check the oil level. Add oil if necessary
	Clogged oil filter	The oil filter needs to be changed
	Defective Thermostat	Contact your local Ozen Distributor
	Clogged cooler	The cooler needs to be cleaned
	Incorrect compressor room layout	The compressor must be installed in accordance with the installation layout instructions.
Compressor stops due to overheating	Incorrect compressor room layout	The compressor must be installed in accordance with the installation instructions.
	Extremely hot operating environment	Maintain the ambient temperature of the compressor to between 32 °F (0 °C) and 115 °F (46 °C.)
	Improper temperature setting	Contact your local Ozen Distributor
	System lacking oil	Check the oil level. Add oil if necessary
	Clogged oil filter	The oil filter needs to be changed
	Clogged air filter	Contact your local Ozen Distributor
	Clogged cooler	The cooler needs to be cleaned
Cabinet panels have been removed	The panels must be in place when the compressor is running	

Temperature increases when compressor is switched to no-load operation	There is blockage in the oil line or oil filter	Contact your local Ozen Distributor
Safety valve is opened	Defective safety valve	Contact your local Ozen Distributor
	Improper setting of the safety valve	Contact your local Ozen Distributor
	The operating pressure setting is wrong	Contact your local Ozen Distributor
	Compressor does not stop automatically	Refer to "Compressor exceeding the desired pressure value"
Oil in the Compressed Air	Defective separator filter	The separator element is required to be replaced
	Clogged oil flow indicator	Contact your local Ozen Distributor
	High oil level	Check the oil level. Empty excess oil if necessary
Oil loses its properties quickly	Failure to use recommended oil	You can get an oil recommendation by contacting your local Ozen Distributor
	High ambient humidity	The ambient humidity must be reduced
	High ambient temperature	The ambient temperature must be reduced
	Gas, dust, etc., is contaminating the oil	The environment must be free of these substances
Compressor does not stop auto-matically at idling	The idle time setting is not proper	Contact your local Ozen Distributor
	Compressor re-loads in a very short time	Contact your local Ozen Distributor
Compressor blows down all the time	Defective Solenoid valve	Contact your local Ozen Distributor
	Power failure in the supply line to the solenoid valve	Check out the line and repair the required parts

FAILURES AND SOLUTIONS

CHAPTER 6

Internal pressure does not relieve when stopping the compressor	Defective air intake valve	Contact your local Ozen Distributor
	Defective minimum pressure valve	Contact your local Ozen Distributor
Phase Protection Warning	Incorrect connection of the phase cables	Two of the phase cables must exchange places
Compressor operates very noisily	Due to motor	Contact your local Ozen Distributor
	Due to coupling	Contact your local Ozen Distributor
	Due to air-end	Contact your local Ozen Distributor
	Due to connections	Contact your local Ozen Distributor

Table-9

TECHNICAL DATA

CHAPTER 7

7.1 COMPRESSOR NAMEPLATE

Ozen Compressed Air Technology and Equipment LLC. 4205 Golf Acres Drive, Charlotte, NC 28208, USA Office : (704) 660 0334 info@ozenairtech.com			
MODEL		SERIAL NUMBER	Manufacturing Year
③		④	⑤
WORKING PRESSURE (PSI-bar)		CAPACITY (Cfm-m ³ /min)	
⑥		⑦	
MOTOR POWER (kW-hp)		MOTOR SPEED (rpm)	MAIN SUPPLY
⑧		⑨	⑩
DIMENSIONS (inch)	WEIGHT (lbs)	OUTLET CONNECTION	PACKAGE AMPS
⑪	⑫	⑬	⑭

01 Manufacturing Company Information and Address

02 Manufacturing Company Logo

03 Compressor Model

04 Compressor Serial Number

05 Year of Manufacture of the Compressor

06 Compressor Output Pressure

07 Compressor Output Capacity

08 Power of Main Motor of the Compressor

09 Main Motor Speed

10 Main Voltage

11 Compressor Dimensions

12 Compressor Weight

13 Compressor Air Outlet Size

14 Package Amps

7.2 COMPRESSOR DATA

MODEL		OASC D 55				
Power	kW	55				
	HP	75				
MAX. OPERATING PRESSURE	Psi	100	125	150	190	
	Bar	6.9	8.6	10.3	13.1	
CAPACITY (FAD)	Cfm	max	357.3	323.1	297.8	248.8
		min	39.6	39.9	39.6	39.6
	m ³ /min	max	10.12	9.15	8.43	7.05
		min	1.12	1.13	1.12	1.12
MOTOR SPEED	rpm	3600				
AIR INPUT TEMPERATURE	°C	20				
	°F	68				
INLET ABSOLUTE AIR PRESSURE	Bar	1				
	Psi	14.5				
SOUND LEVEL	(db)	76				

Table-10

TECHNICAL DATA

CHAPTER 7

7.3 POWER CABLE DIMENSIONS

 WIRE SIZE		60°C (140°F)		75°C (167°F)		MAIN MOTOR POWER	MAIN MOTOR POWER
						(460 V)	(208V - 230V)
AWG	mm ²	Copper	Aluminum	Copper	Aluminum	kW	kW
12	3.3	20	15	20	15	4	-
12	3.3	20	15	20	15	5.5	-
10	5.3	30	25	30	25	7.5	-
10	5.3	30	25	30	25	11	4
8	8.4	40	30	50	40	15	5.5
8	8.4	40	30	50	40	18.5	7.5
6	13.3	55	40	65	50	22	11
6	13.3	55	40	65	50	30	15
4	21.2	70	55	85	65	37	18.5
4	21.2	70	55	85	65	45	22
1	42.4	110	85	130	100	55	30
1/0	53.5	-	-	150	120	75	-
1/0	53.5	-	-	150	120	90	-
3/0	85.0	-	-	200	155	110	-
4/0	107.2	-	-	230	180	132	-

Table-11

Cable dimensions in the table are in accordance with UL standards. These measurements are valid for cables having a length of up to 50ft (15m.) For connections greater than 50ft, the cable selected must be one size higher.

NOTE: Cable and fuse sizes are a recommendation. Always size electrical components per local codes and regulations.

7.4 PRELIMINARY FUSE ON SITE

PRELIMINARY FUSE ON SITE-PFS (Amps)		
kW	208-230 V	460 V
4	25	10
5	32	16
7	40	30
11	50	40
15	80	50
18	80	50
22	100	63
30	125	80
37	-	80
45	-	100
55	-	125
75	-	150
90	-	170
110	-	
132	-	
160	-	
200	-	
250	-	
315	-	

Table-12

TECHNICAL DATA

CHAPTER 7

7.5 FUSE SPECIFICATIONS BY COMPRESSOR

 460 VOLT COMPRESSOR FUSE CURRENTS (Amps)							
kW	F1 (Time Delay)	F2 (Time Delay)	F3	F4	F5	F6	F7
4	1	1	6	2½	3½	3½	10
5.5	1	1	6	2½	3½	3½	10
7	1	1	6	2½	3½	3½	10
11	1	1	6	2½	3½	3½	10
15	1	1	6	2½	3½	3½	10
18.5	1	1	8	2½	5	5	16
22	1	1	8	2½	5	5	16
30	1	1	8	2½	5	5	16
37	1	1	10	2½	-	-	-
45	1	1	10	2½	-	-	-
55	1	1	12	2½	-	-	-
75	1	1	12	2½	-	-	-
90	1	1	12	2½	-	-	-
110	1	1	16	2½	-	-	-
150	1	1	16	2½	-	-	-

Table-13

Ozen Compressed Air Technology and Equipment, LLC.
4205 Golf Acres Drive Charlotte NC 28208
Office (704) 660-0334
E-mail info@ozenairtech.com

