

 (704) 660-0334

Appropriate solutions for all your **compressed air needs**



OPERATOR MANUAL FOR OASC 37 / OASC 45 COMPRESSOR

www.ozenairtech.com

 **ozen**
AIR TECHNOLOGY

EXCLUSIVELY COMPRESSED AIR SOLUTIONS

TABLE OF CONTENTS

1.	CHAPTER / SAFETY	6	
1.1	SAFETY SYMBOLS AND GENERAL SAFETY MEASURES	6	
2.	CHAPTER / INSTALLATION.....	10	
2.1	HANDLING AND INSTALLATION OF THE COMPRESSOR	10	
2.2	VENTILATION AND COOLING.....	16	
2.3	SERVICE AIR PIPES	21	
2.4	ELECTRICAL CONNECTION	23	
	2.4.1 ELECTRIC DIAGRAMS 208-230 VOLT	25	
2.5	INSTALLATION CONTROLS	31	
	2.5.1 BELT PULLEY INSPECTION.....	31	
	2.5.2 OIL LEVEL CHECK.....	32	
	2.5.3 MOTOR ROTATION DIRECTION CONTROL	34	
3.	CHAPTER / THE SYSTEM OF COMPRESSOR.....	36	
3.1	INTRODUCTION/DEFINITION	36	
3.2	COMPONENTS.....	37	
	3.2.1 MOTOR & AIR-END GROUP	37	
	3.2.1.1 ELECTRIC MOTOR.....	37	
	3.2.1.2 AIR INTAKE GROUP.....	38	
	3.2.1.3 SEPARATOR GROUP.....	39	
	3.2.1.3.1 SEPARATOR TANK.....	39	
	3.2.1.3.2 SEPARATOR COMBINATION BLOCK.....	40	
	3.2.1.3.3 SEPARATOR	40	
	3.2.1.3.4 OIL FILTER.....	41	
	3.2.1.4 AIR-END	41	
	3.2.1.5 BELT AND PULLEY SYSTEM.....	41	
	3.2.1.6 AIR-END BASEPLATE	41	
	3.2.2 COOLING SYSTEM.....	42	
	3.2.3 OPERATOR PANEL.....	42	
	3.2.4 ELECTRICAL CABINET	43	
	3.2.5 COMPRESSOR CABINET	45	
4.	CHAPTER / HOW IT OPERATES	46	
4.1	GETTING STARTED.....	46	
4.2	CONTROL PANEL	48	
	4.2.1 MAESTRO 22 CONTROL PANEL DISPLAY	49	
	4.2.2 CODES AND DESCRIPTIONS OF ALARMS	50	
	4.2.3 MAINTENANCE CODES.....	51	
	4.2.4 DESCRIPTION OF THE STATUS IMAGES		
	ON THE HOME SCREEN	52	
	4.2.5 CONTROL PANEL USER SETTINGS.....	53	
	4.2.6 CONTROL PANEL OPERATION SETTINGS.....	54	
4.3	DAILY OPERATING INSTRUCTIONS.....	59	
5.	CHAPTER / MAINTENANCE	60	
5.1	PREVENTIVE MAINTENANCE INTERVALS.....	60	
	5.1.1 GENERAL DESCRIPTION	60	
	5.1.2 DAILY MAINTENANCE	61	
	5.1.3 WEEKLY MAINTENANCE	61	
	5.1.4 COMPRESSOR MAINTENANCE INTERVALS.....	62	
	5.1.4.1 AIR-END AND MOTOR	63	
	5.1.4.2 OIL SPECIFICATIONS, CHECK AND REPLACEMENT.....	63	
	5.1.4.3 OIL FILTER AND SPIN-ON SEPERATOR REPLACEMENT.....	68	
	5.1.4.4 CLEANING AND REPLACEMENT OF AIR INTAKE FILTER.....	71	
	5.1.4.5 INSPECTION AND REPLACEMENT OF SAFETY VALVE.....	72	
	5.1.4.6 REPLACEMENT OF MINIMUM PRESSURE VALVE	73	
	5.1.4.7 REPLACEMENT OF THERMOSTATIC VALVE	74	
	5.1.4.8 CHECK AND REPLACEMENT OF AIR INTAKE		
	VALVE (SUCTION FLAP)	75	
	5.1.4.9 INSPECTION AND REPLACEMENT OF BELT	76	
	5.1.4.10 INSPECTION AND CLEANING OF COOLING GROUP ..	78	
	5.1.4.11 OIL TEMPERATURE SENSOR REPLACEMENT.....	78	
	5.1.4.12 MAINTENANCE AND REPLACEMENT OF		
	CABINET FILTERS AND HOSES.....	79	
6.	CHAPTER / FAILURES AND SOLUTIONS	80	
7.	CHAPTER / TECHNICAL DATA.....	84	
7.1	COMPRESSOR NAMEPLATE	84	
7.2	COMPRESSOR DATA	85	
7.3	POWER CABLE DIMENSIONS.....	86	
7.4	PRELIMINARY FUSE ON SITE.....	86	
7.5	FUSE SPECIFICATIONS AS PER COMPRESSORS.....	87	
7.6	CONTACTOR CURRENT DRAW BY COMPRESSOR SIZE	88	

THE DETAILS THAT DELIVER THE RIGHT RESULTS...

EXPERIENCE

Ozen Air Technology, with its industry experience of half-a-century and its large portfolio of compressed air products, provides reliable, efficient, and smart solutions

TRUST

Ozen's dedication to customer satisfaction has helped the company to build lasting relationships of trust and loyalty with its customers.

DURABLE AND EFFICIENT

All of the compressed air equipment in Ozen's portfolio have proven their durability under the toughest conditions. They provide high-quality, high-efficiency air.

QUALITY

Consistently manufacturing high-quality products is one of Ozen's fundamental tenets. To that end, Ozen continuously enhances its quality policies.





TECHNOLOGY

Ozen Air Technology is innovative. It always uses up-to-date technologies in compliance with world-standards.

R & D

With its creative team and competent infrastructure, Ozen is capable of developing its own technology through collaborations with several universities.

STRONG SERVICE NETWORK

Ozen Air Technology believes in maintainability. Its customers can enjoy uninterrupted manufacturing thanks to its accessible, fast, and reliable service network.

COMPETITIVE

Ozen Air Technology acts in favor of its customers. Providing them with leverage is one of Ozen's strong suits.

RESPECT FOR THE ENVIRONMENT

Striving for a sustainable future, Ozen Air Technology selects for environmentally friendly practices and takes all necessary precautions while structuring its work processes.

SAFETY

CHAPTER 1

1.1 SAFETY SYMBOLS AND GENERAL SAFETY MEASURES

This manual must be read in its entirety and completely understood in order to operate the compressor safely and correctly. The safety instructions must be read carefully and all warnings must be strictly adhered to. Follow all local requirements, such as lock-out/tag-out procedures and the wearing of proper personal protection equipment, before attempting to service this equipment.



HOT OIL AND COMPRESSED AIR

Before replacing the separator, make sure the system is switched off and the air in the system is completely evacuated. Otherwise, when the system is loosened, there may be an explosion or skin burns when touched.



FLAMMABLE OIL

Exercise caution when working near or with oil. Do not expose oil to open flames and refrain from smoking near oil storage areas.



ROTATING PARTS

Make sure that your hands and body are kept safely away from the fan area before operating the compressor. Severe injuries can occur if your hands or body are stuck in the rotating parts.

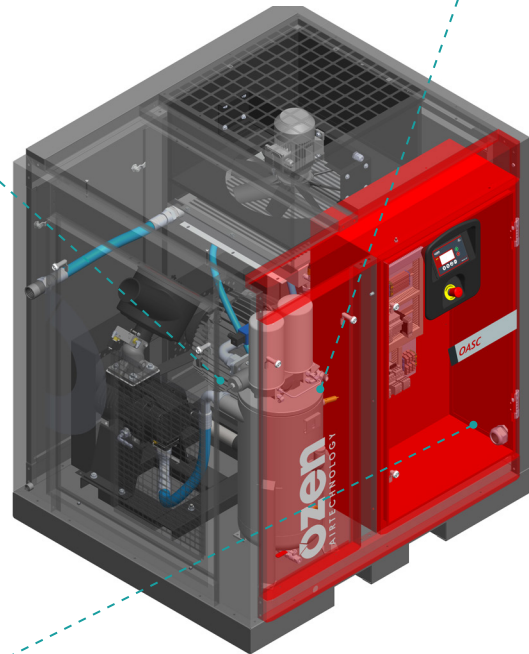

ELECTRIC SHOCK

Make sure that the power is disconnected and proper lock-out/tag-out is performed before connecting the compressor to the power supply or before servicing. Do not open the electrical cabinet cover before the power is turned off.



ELECTRIC POWER

Do not apply power until the installation is complete. Compressor must be properly grounded and adhere to local electrical codes.



HAND CAUGHT IN THE COVER

Exercise caution when removing or installing machine panels. Panels can become pinch points, especially when the machine is operating.



HOT SURFACES

Touching hot surfaces can cause severe burns and injuries. Avoid contacting until machine has cooled.



FIRE

Perform proper oil level checks per the maintenance schedule. A low oil level may cause the machine to overheat. Although the oil has a high auto-ignition value, fire can occur in very extreme cases. Proper grounding is required on all electrical circuits.



HOT OIL PRESSURE

Before replacing the compressor oil, stop the compressor and make sure that the air is completely evacuated.



OIL LEVEL CHECK

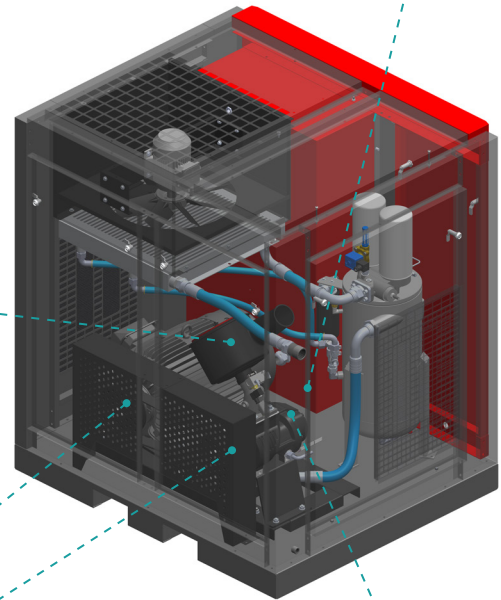

ROTATING PARTS

Make sure that your hands and body are kept safely away from the belt and pulley area before operating the compressor. Severe injuries or death may occur in cases when your hands or body are caught in the rotating parts.



RESPIRATORY DISORDERS

Air discharged from the air compressor may contain oil and particulates. It is hazardous to directly inhale the air from the compressor.



COMPRESSED AIR

The air pressure exiting the compressor may be powerful. Ensure that the air outlet is tight and properly sealed before operating the compressor.

SAFETY

CHAPTER 1

GENERAL WARNING ICONS



IMPORTANT!

This symbol and the word "IMPORTANT!" contain important information about the use of the compressor. Read the information in these sections thoroughly for the compressor to be operated efficiently.



ATTENTION!

This symbol and the word "ATTENTION!" indicate the possible hazards that may be caused to the person and the environment. Failure to observe the warnings in this section may cause personal injury.



DANGER!

This symbol and the word "DANGER!" indicate the potential hazards that may be encountered. If ignored, it may result in serious personal injury or death.

GENERAL SAFETY ICONS

Read the general safety icons and descriptions carefully before using your compressor. Observe the safety notes in the sections in which you see these icons. Failure to observe safety icons may result in injury or death.



HOT OIL AND COMPRESSED AIR

Machine contains hot oil and compressed air. Exercise caution when performing any service work or repair. System pressure must always be completely relieved any time the system is opened. Failure to do so may result in equipment damage, person injury, or death.



FLAMMABLE OIL

Machine contains hot oil under pressure. Exercise caution whenever working with the oil system and never perform any service or repair while machine is under pressure or in operation.

**ROTATING PARTS**

Keep away from the rotating parts (fan, etc.) when the compressor is running. Contact with rotating parts may result in serious bodily harm or death.

**ROTATING PARTS**

Keep away from the rotating parts (belt and pulley system, etc.) when the compressor is running. Contact with rotating parts may result in serious bodily harm or death.

**ELECTRIC SHOCK**

Do not come into contact with live electrical components and/or cables. Doing so will result in electric shock, leading to severe injury or death. Always wear appropriate PPE (Personal Protective Equipment) per NFPA 70E and local regulations.

**PINCH POINT**

Keep hands away from the openings when removing or installing machine panels, especially when the machine is in operation. Suction from the machine may cause fingers or body parts to become pinched, causing injury.

**HOT SURFACES**

Do not touch the hot surfaces of the compressor when the compressor is operative or inoperative. Doing so may cause injuries.

**RESPIRATORY DISORDERS**

Do not breathe compressed air discharge. It is not meant for breathing air and can cause respiratory damage.

**EARPLUG USE**

Use earplugs while the compressor is running. Otherwise, you may experience hearing loss.

**ELECTRIC POWER**

Do not perform any work or repairs on live electrical circuits. Always remove electrical power, perform lock-out/tag-out procedures, wear proper PPE, and take safeguards to provide protection against electrical shock. Electrical shock will cause serious injury or death.

INSTALLATION

CHAPTER 2

2.1 HANDLING AND INSTALLATION OF THE COMPRESSOR

Compressors can be transported by crane or forklift. Compressors may fall or be tipped due to improper transport. This will cause serious damage to the compressor and/or personal injury or even death.

Transport of a compressor by forklift:

TRANSPORT METHOD FOR THE OASC 37-45 SERIES COMPRESSORS WITH FORKLIFT

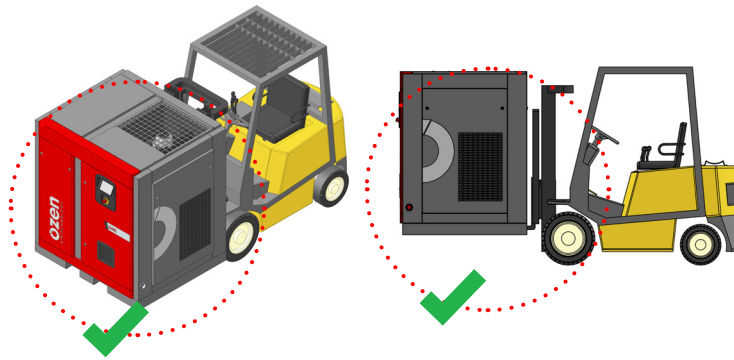

PROPER TRANSPORTATION

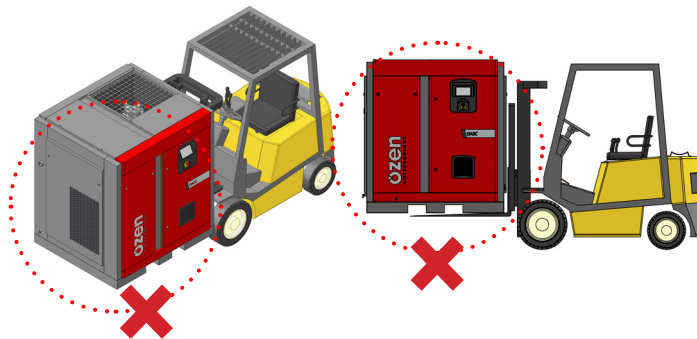

IMPROPER TRANSPORTATION

- ▶ For the stable lifting of the compressor, the forks of the forklift must be equally inserted into the forklift slots located on the sides of compressors and lifted. If the directions are not followed, the compressor can overturn and cause serious damage to the compressor or personal injury.
- ▶ The forklift's lifting mast must not be inclined forward when lifting the compressor.
- ▶ The front and rear floor openings of the compressor are not intended for the forklift. Do not use them for lifting purposes. Only use the forklift slots on the sides reserved for the forklift.
- ▶ Select a suitable forklift that is recommended for the weight of the compressor.



ATTENTION!

If the weight of the truck to be used to transport the compressor transport is not selected according to the size of the compressor, then the forklift may incline forward and tip over due to excess weight. This will lead to substantial material damage and/or personal injury.

INSTALLATION

CHAPTER 2

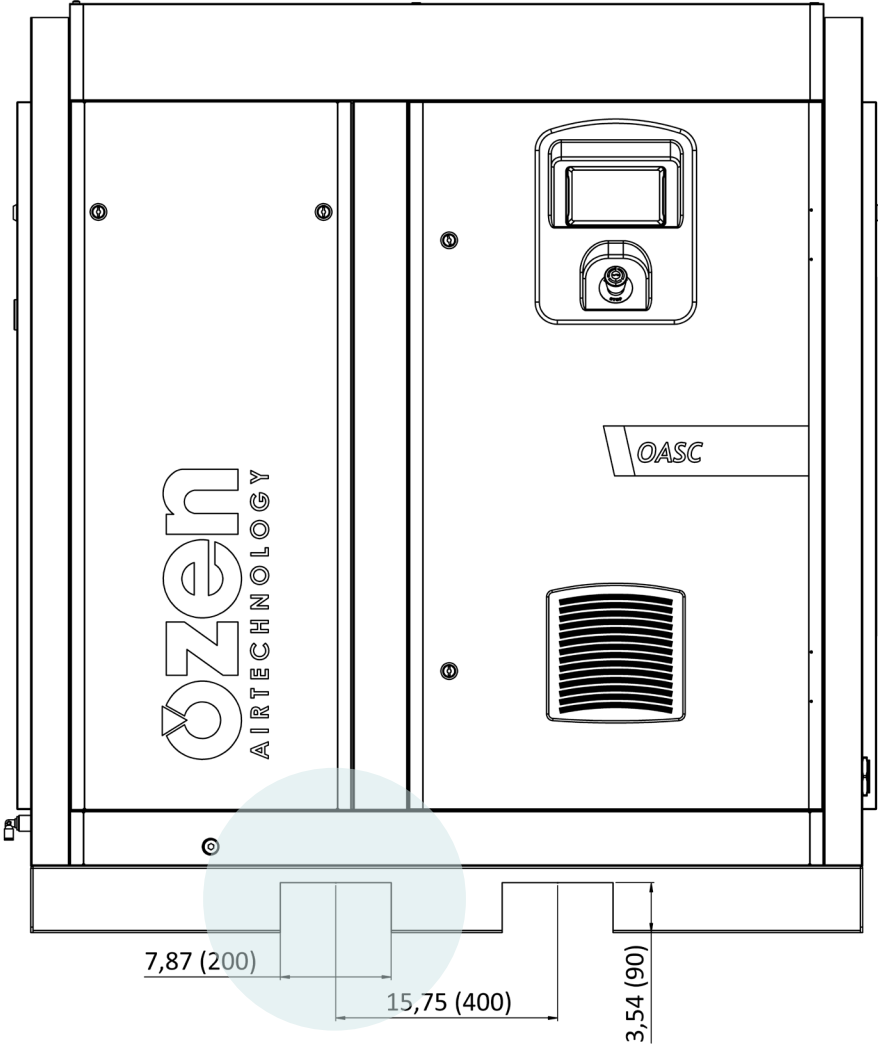

Note: All measurements are in inches (mm)

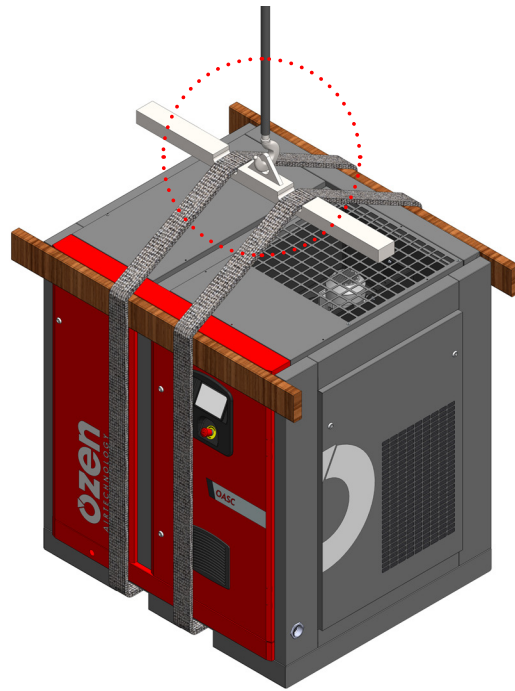
Transportation of the compressor by crane:

- ▶ For OASC 37 and OASC 45 series, in order to lift compressor in a balanced way, rope should be placed properly through forklift service spaces that place front and back of compressor. Ropes should have the same length.
- ▶ While ropes are being set, woods need to be placed between ropes and canopy in such a way above the covers in order to avoid to damage canopy.
- ▶ While lifting the compressor please be sure that ropes only touch to wood. Otherwise canopy can be crushed or bent.
- ▶ Since both sides of compressor aren't suitable to be lift by crane, please only use forklift service space that place front and back of compressor.

**ATTENTION!**

Do not stand under and near the compressor when transporting the compressor by crane. Failure of the lifting devices will cause the load to fall, causing personal injury or death.

INSTALLATION

CHAPTER 2

Installation of a compressor:

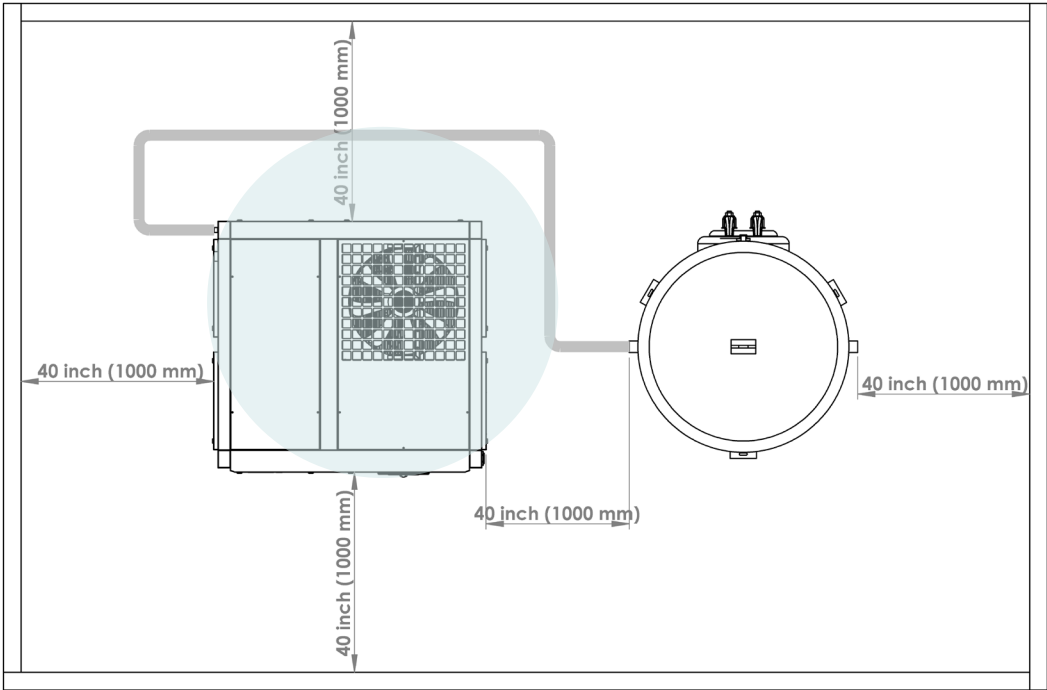

The following considerations should be taken into account before locating a compressor:

- ▶ The floor for the compressor must be flat.
- ▶ Ensure that the dimensions and ventilation of the compressor room are appropriate.
- ▶ The compressor room must have enough lighting.
- ▶ Provide the appropriate power supply to the compressor.
- ▶ Take appropriate fire precautions per local laws and regulations.
- ▶ Compressor accessibility must adhere to recommended clearances and all escape routes and rescue equipment must be accessible.
- ▶ The compressor room must be free of dust.
- ▶ No electrical or electromagnetic devices that may cause disturbances should be around the compressor room.
- ▶ Make sure that the compressor is not directly exposed to rain, moisture, and extreme low and high temperatures.
- ▶ Ensure that the compressor is not directly placed in a corrosive environment.
- ▶ If your compressor is a tank-mounted model, there is no need for an additional air tank because such an assembly is already equipped with one. The room is to be designed according to the tank-mounted air compressor size.
- ▶ Provide the compressor room with a fixed or portable crane in order to facilitate the maintenance and servicing operations.



ATTENTION!

The temperature and humidity (climatic conditions) of the environment in which the compressor is to be placed has an effective role in the operation of the compressor. Ensure that adequate protection is provided to the ambient conditions that affect the operation of the compressor.

When locating a compressor:

- ▶ The compressor must have a minimum clearance of 40 inches (1000 mm) between the walls and the other components in the room (if any) to allow for unobstructed air intake and discharge. There must be at least 60 inches (1500mm) between compressor and the roof. These are very important dimensions for easy servicing. Service personnel may not be able to fulfill their work if these dimensions are less.
- ▶ Install separate lines for the condensate drains of the compressor, dryer, filters, and air receiver. Otherwise, water may gather in the vicinity of the air compressor.
- ▶ The air inlet sides of the compressor cabinets must always face in the direction of cool air. Take this into consideration when designing the layout of the room and placement of the compressor.
- ▶ The room where the compressor is to be operated must have an appropriate air flow. The compressor must not draw in the hot air that is discharged from compressor. The clean and cool air entering the room must have a velocity of less than 13 ft/sec (4 m/sec.).
- ▶ On the models equipped with an aftercooler, there may be some oil in the water that is discharged from the compressor. An oil/water separator may be required before disposing the water into the drain. Check the local environment and safety standards that you are subject to.

INSTALLATION

CHAPTER 2

2.2 VENTILATION AND COOLING

The heat generated by the air compressor can quickly increase the compressor room ambient temperature beyond the maximum rated ambient temperature for the machine. In order to prevent this, ventilation for the compressor room must be provided. Please refer to the Cooling & Ventilation Data chart on page 18.

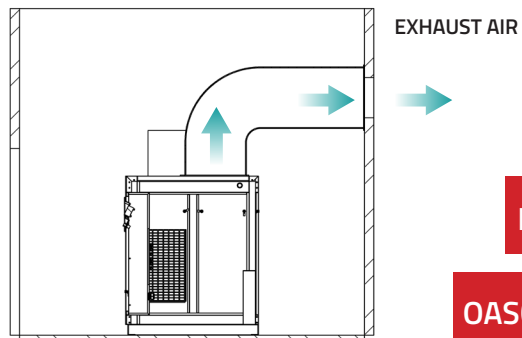
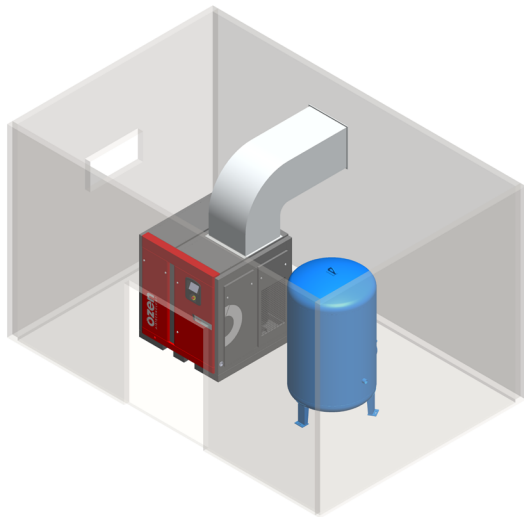

FIGURE A

OASC 37-45 SERIES

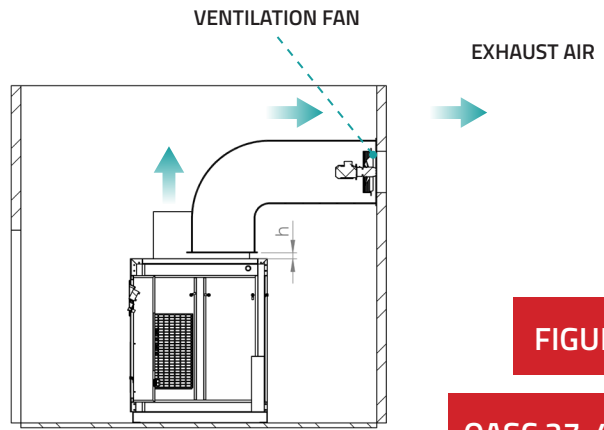
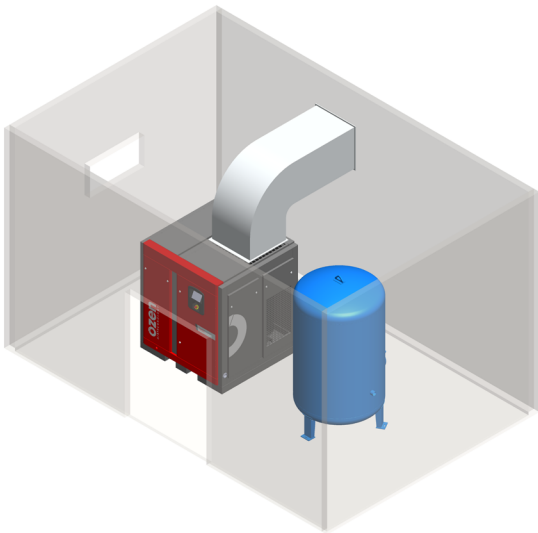

FIGURE B

OASC 37-45 SERIES

INSTALLATION

CHAPTER 2

The compressor room ventilation blowers are recommended to be on the air intake side of the compressor. This allows the compressor to reach clean air more easily and quickly.

Avoid long runs of ducting and keep bends to a minimum, especially those that are 90 degrees. Ducting must be at least as large as the opening on the hot air discharge of the compressor and must be over-sized in instances of long runs and excessive bends. Failure to do so will result in back-pressure being applied to the cooling fan, which will cause the compressor to overheat. Refer to Table-1 for cooling data and back-pressure limits to assist in sizing and engineering of duct work.

If the difference between the outlet pressure of suction fan in the compressor and the outlet pressure of the ventilation duct system is less than defined value below at Table-1, then FIGURE A is preferred. If greater, then FIGURE B is preferred.

If FIGURE B is preferred, the gap (h) between the compressor and ventilation hood must range between 8-12 inches (200 - 300 mm).

Cooling & Ventilation Data			
Model:		OASC 37	OASC 45
Heat generation BTU/h (MJ/h)		126,249.25 (133.2)	153,546.39 (162.0)
Air Exhaust cfm (m ³ /min)		5827 (165)	9182 (260)
Fan Capacity	Ventilation Type A cfm (m ³ /min)	N/A	N/A
	Ventilation Type B cfm (m ³ /min)	6180 (175)	9535 (270)
	Ventilation Type C (without duct) cfm (m ³ /min)	14832 (420)	22955 (650)
	Pressure loss allowed " H2O (Pa)	0.40 (100)	0.44 (110)

Table-1

In order to prevent the re-circulation of hot air exhaust, the inlet air vent to the compressor room must not be located on the same wall as the hot air exhaust. It is best to locate the two vents on opposite walls for cross-ventilation or at least on an adjacent wall, as shown on the figures.

Air intake grills installed in the compressor room must be designed so as to prevent ingress of water (rain) and debris (leaves, dust, etc.)

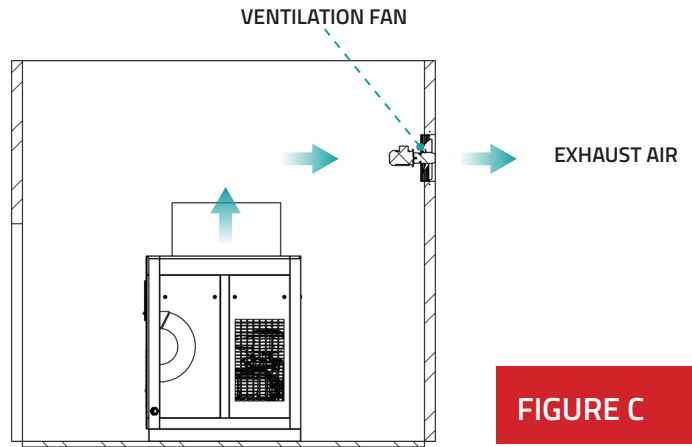
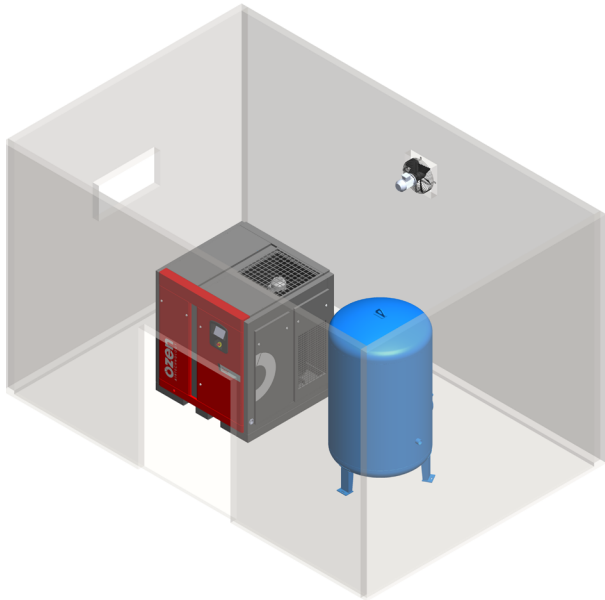

FIGURE C

OASC 37-45 SERIES

INSTALLATION

CHAPTER 2

When a fan is used for the purpose of hot air exhaust removal, the capacity of the fan must be as close as possible to that of the air compressor cooling fan. Failure to size the exhaust fan properly will result in the pulling of a vacuum in the room or inadequate evacuation of the hot air exhaust, which may result in overheating of the compressor.

Placement of the intake and discharge grills may differ from the figure due to actual placement of the air compressor.

2.3 SERVICE AIR PIPES

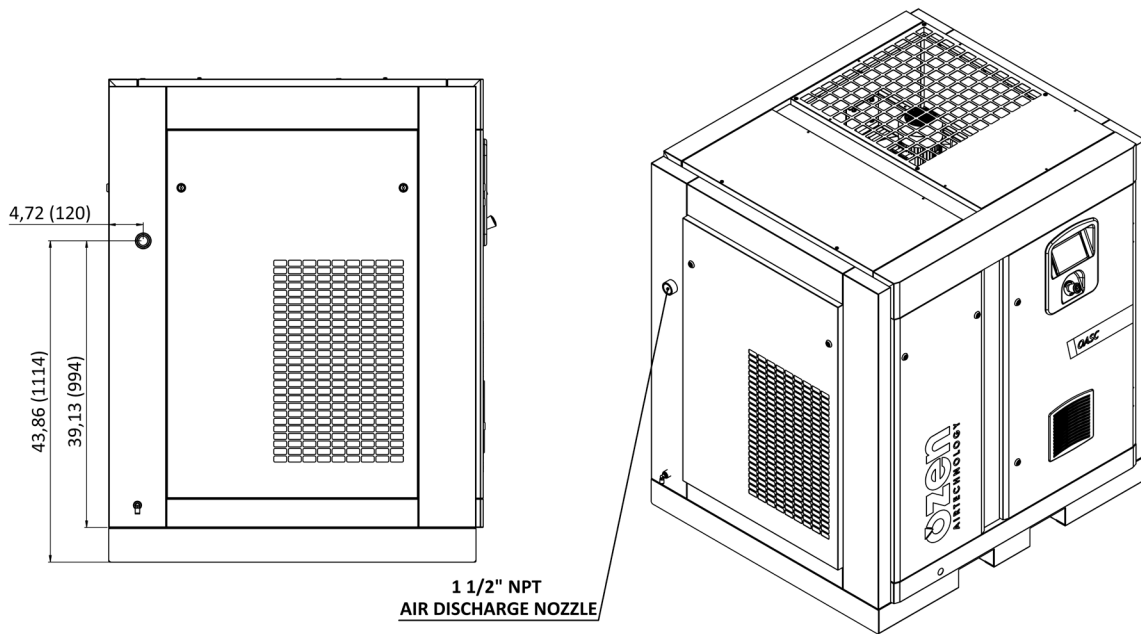

Compressor service air outlet pipes are placed side of OASC 37 and OASC 45. Dimensions are defined in Table 2.

Note: All measurements are in inches (mm)

INSTALLATION

CHAPTER 2

MODEL	AIR DISCHARGE SIZE
OASC 37	1 ½" NPT
OASC 45	1 ½" NPT

Table-2



IMPORTANT!

The table located on the left demonstrates the diameters of air outlet hose related to the Ozen Air Technology rotary screw air compressors mentioned in this manual.

System piping size must never be smaller than the size of the air compressor discharge. Reducing the piping size will result in overpressurization of the compressor.

2.4 ELECTRICAL CONNECTION



DANGER!

Always verify that the power supply is de-energized when making any electrical connections. Failure to do so may result in electric shock, which will cause bodily harm or death.

All electrical connections should be made by a Licensed Electrician or a qualified Ozen Distributor Service Professional. Incoming power connection must be made through the cabinet penetration shown below in Detail A.

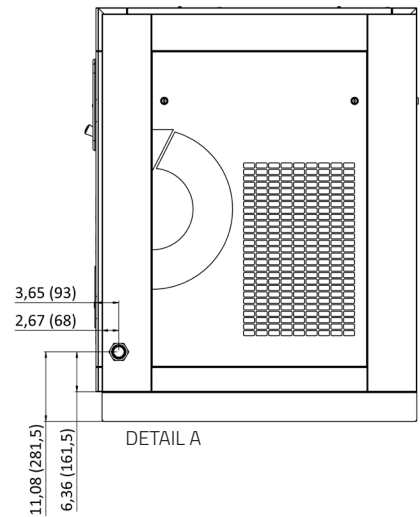

Fulfill the power connection with cables having UL-Standard as per electrical connection diagram. Carefully examine the data in the electrical diagram. Check that your supply network is in compliance with this data. Maximum voltage deviation is +/- 10%, maximum voltage drop when compressor is started is 10%, and maximum sustained voltage drop after the compressor is running is 6%. Maximum voltage imbalance is 1% and maximum current imbalance is 5%.

DETAIL A



Note: All measurements are in inches (mm)

INSTALLATION

CHAPTER 2

When selecting the power cable size, refer to the Total Loaded Power for the main motor which is specified in the "Engineering Data Sheets".

Use Table 12 in Chapter 7.3 to select the electrical cable. This table shows the power connection cable dimensions for each kW motor. All cabling, main fuses, and main breakers must be sized applicable to local electrical codes. Any references in this manual are suggestions, only.

When connecting the power cables, ensure that they are properly secured so as to not create a tripping hazard.

Make sure that the power cables are securely tightened to the connection terminals.

If the phase connections are wrong, either the motor will turn in the opposite direction or the compressor will not operate. Check the rotation direction of the motor when you operate the compressor for the first time. If the rotation direction is not correct, swap two of the incoming power lines to reverse rotation.

Always verify that the machine is wired to the correct voltage that matches your incoming power by checking the label inside the electrical panel door and the compressor data tag located on the outside of your compressor. To convert your compressor to a different voltage, please contact your local Ozen Distributor.

A fused disconnect or circuit breaker according to PRELIMINARY FUSE ON SITE - PFS (A) list and code requirements must be provided by the customer. The PFS (amps) value is available at table 13 section 7.4



ATTENTION!

The grounding cable must be attached to the terminal block during the installation of incoming power. The terminal reserved for the grounding cable is located next to the incoming power phase connections. If this is not completed, the entire compressor can become electrified and electric shock can occur, causing bodily injury or death.

2.4.1 ELECTRIC DIAGRAMS 460 VOLT

■ ELECTRICAL DIAGRAM FOR OASC 37 / OASC 45

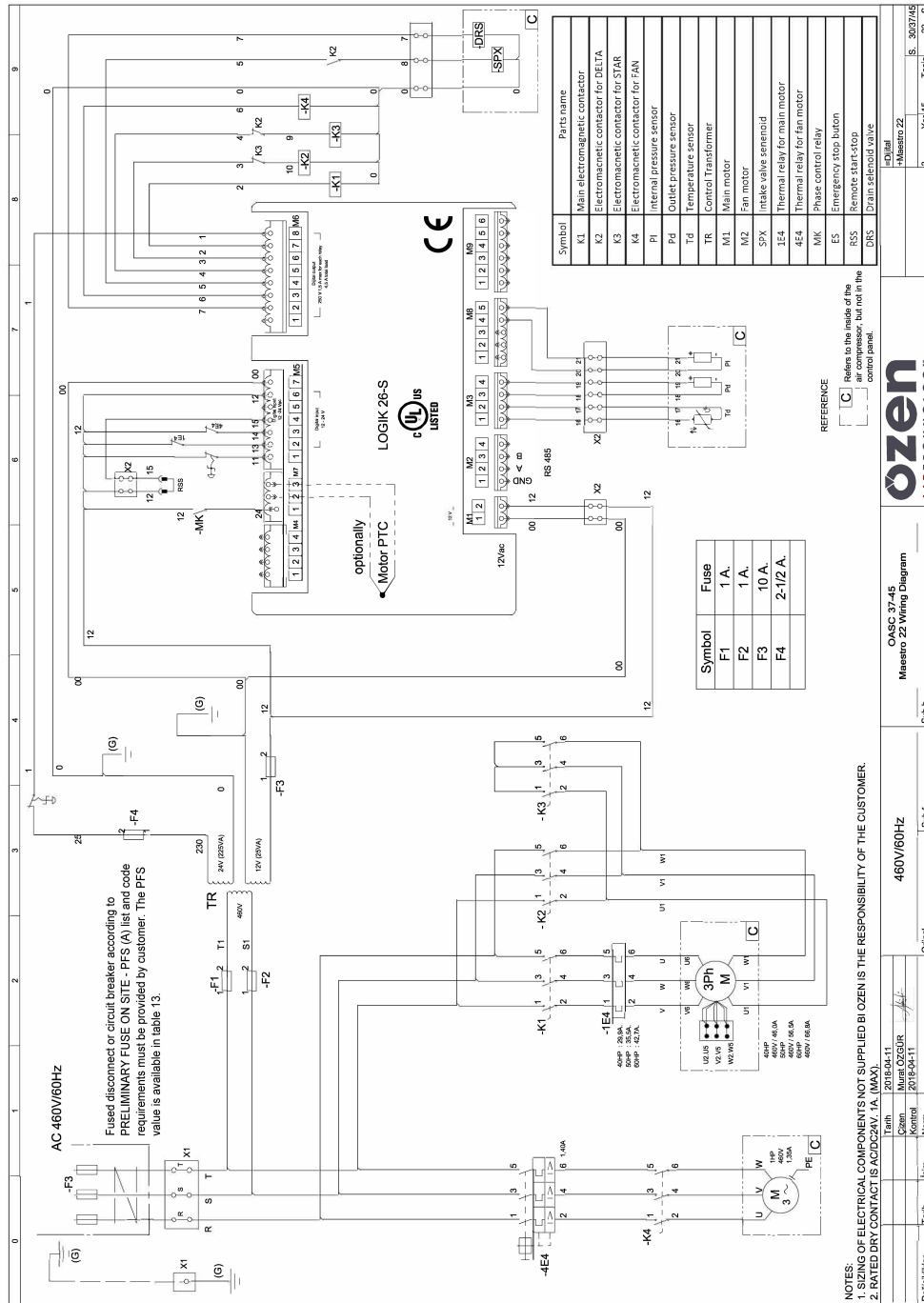

INSTALLATION

CHAPTER 2

2.5 INSTALLATION CONTROLS

2.5.1 BELT PULLEY INSPECTION

The tensioning process of the belt and pulley system of the Ozen Air Technology compressor is carried out by adjusting the motor plate. The rotary screw airend will remain stationary. The belt and pulley system is tensioned by means of the tensioning stud bolt in the motor plate.

You should measure the alignment of the motor and air-end pulleys by the use of a laser tool or straight edge whenever installing a new pulley, replacing a belt, or if misalignment is suspected due to premature belt failure.

Check the belt and pulley tension with an approved tension meter before operating your compressor.

For the inspection and replacement of the belt you may refer to "Chapter 5 / 5.1.4.9 - Inspection and Replacement of Belt".

If you detect any problems with the belt and pulley system during the operation of your compressor, you should immediately shut down your compressor and take necessary measures to secure it against any accidental restart. Contact an authorized Ozen Distributor for analysis and repair.

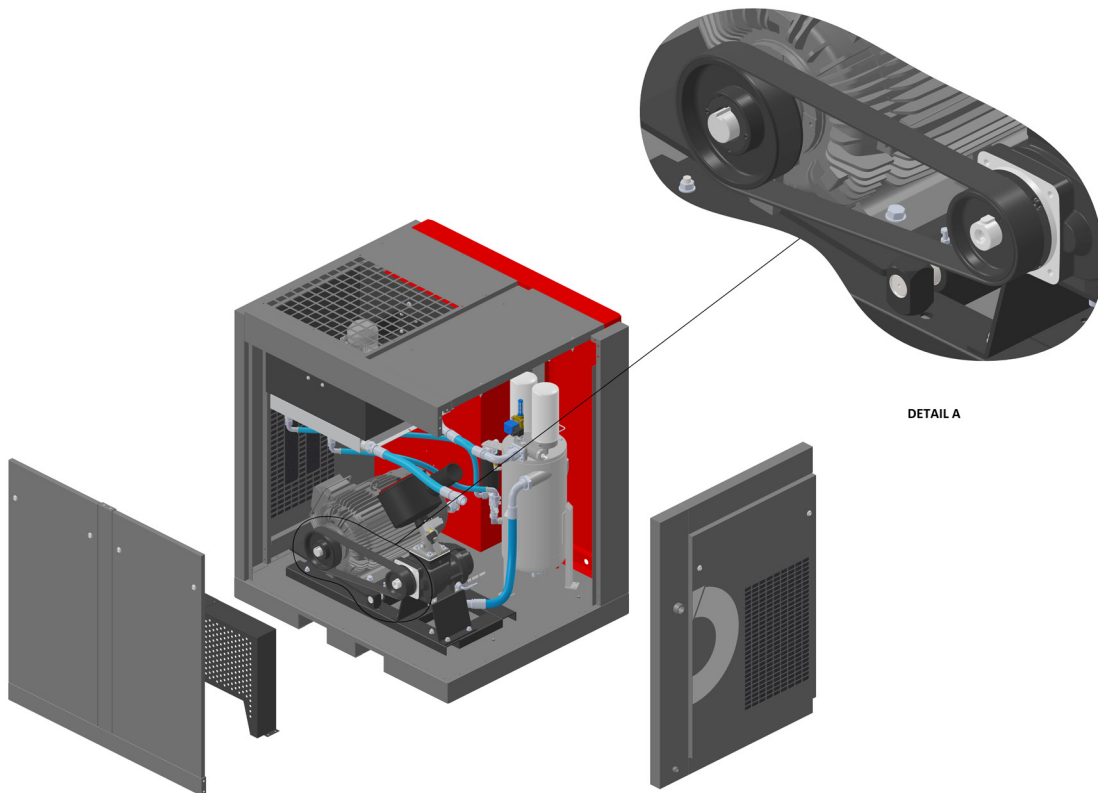

DETAIL A



ATTENTION!

Do not operate the compressor with any cabinet panels removed.



INSTALLATION

CHAPTER 2

2.5.2 OIL LEVEL CHECK

The oil necessary for the operation of the compressor is contained inside of the separator tank. Check the oil level before operating for the first time and then on a daily basis thereafter.

Check the oil level when the compressor is not operating. The correct oil level can not be determined when the compressor is operating. Allow at least 10 minutes after the compressor has stopped operating before checking the oil level.

Check the oil level on the sight glass located on the separator tank.

The required oil level should be at least half of the sight glass. The oil level should not completely fill the sight glass. If it is completely filled there may be a compressor malfunction due to the high oil level. A high oil level will also result in excessive oil carry-over into your system piping. This will foul any in-line filter elements and cause coating and failure of the desiccant inside of a desiccant air dryer, if present.



✗ Completely Empty Tank



✓ Half full Tank

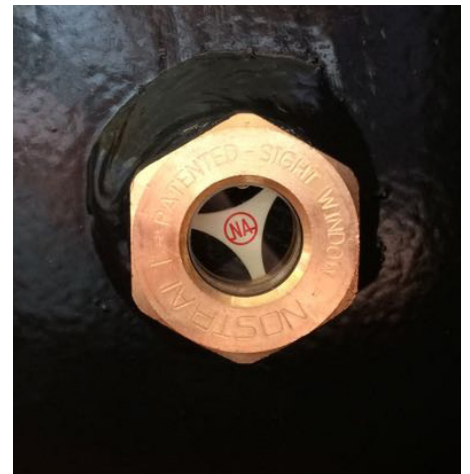

✗ Completely full Tank

If there is no oil observed on the sight glass, the compressor must be immediately shut down and measures must be taken to prevent the compressor from being started again. Contact an authorized Ozen Distributor for analysis and repair.

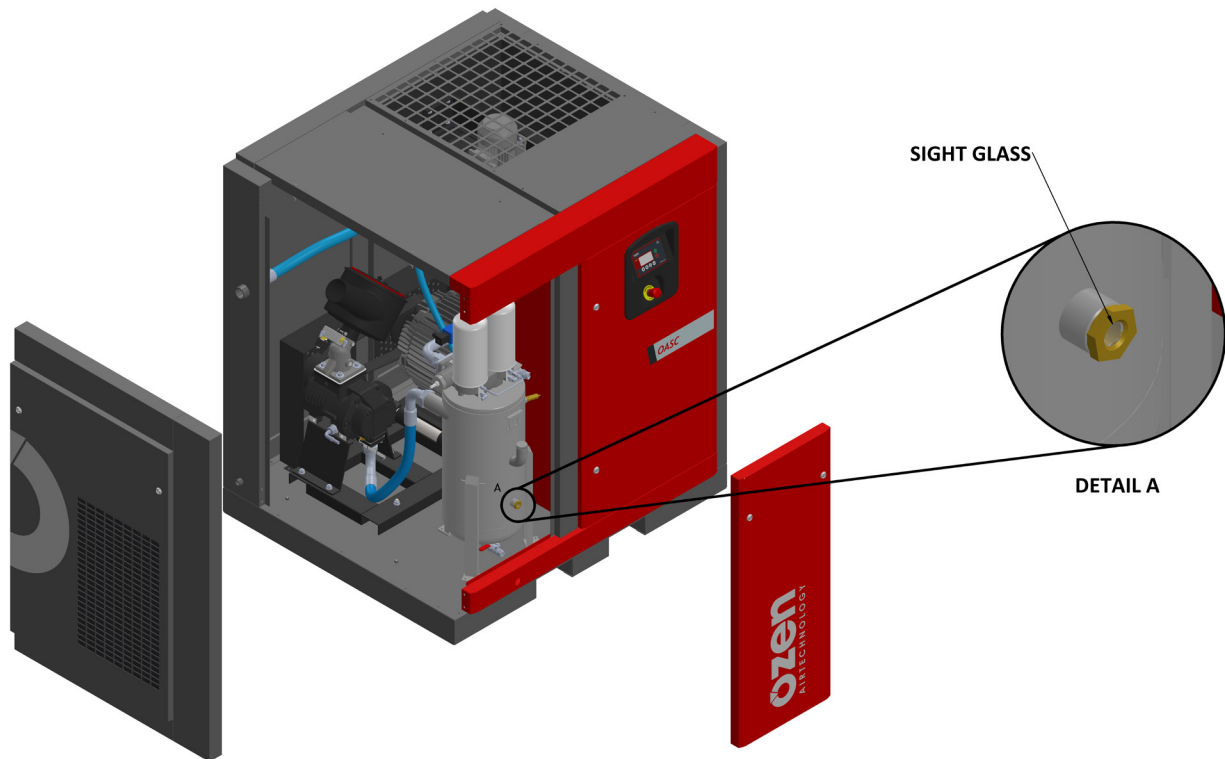

ATTENTION!

Always ensure that the oil fill plug has been reinstalled and tightened after removal to add oil. Do not operate the compressor with any cabinet panels removed.



INSTALLATION

CHAPTER 2

2.5.3 MOTOR ROTATION DIRECTION CONTROL

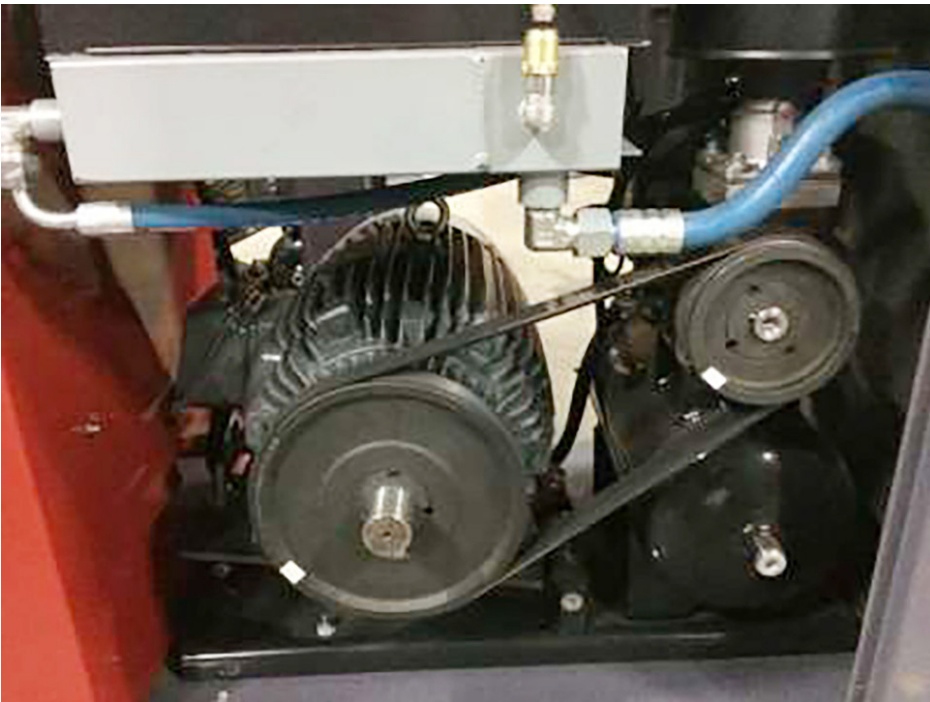

Although Ozen installs phase protection to ensure proper motor rotation on each and every compressor that is manufactured, it is recommended to manually verify that correct motor rotation is established. Verify correct rotation according to the arrow decal placed on the motor.

A phase sequence relay communicates with the Maestro controller and will prevent starting of the compressor if incorrect rotation is sensed.



ATTENTION!

Do not operate the compressor with any cabinet panels removed.



THE SYSTEM OF COMPRESSOR

CHAPTER 3

3.1 INTRODUCTION/DEFINITION

This chapter shows the general components constituting the Ozen Air Technology rotary screw air compressors. Ozen Air Technology compressors are air-cooled, oil-injected and electric motor driven screw compressors.

All components of the Ozen Air Technology screw air compressors are assembled in a closed steel sheet-metal casing providing sound insulation.

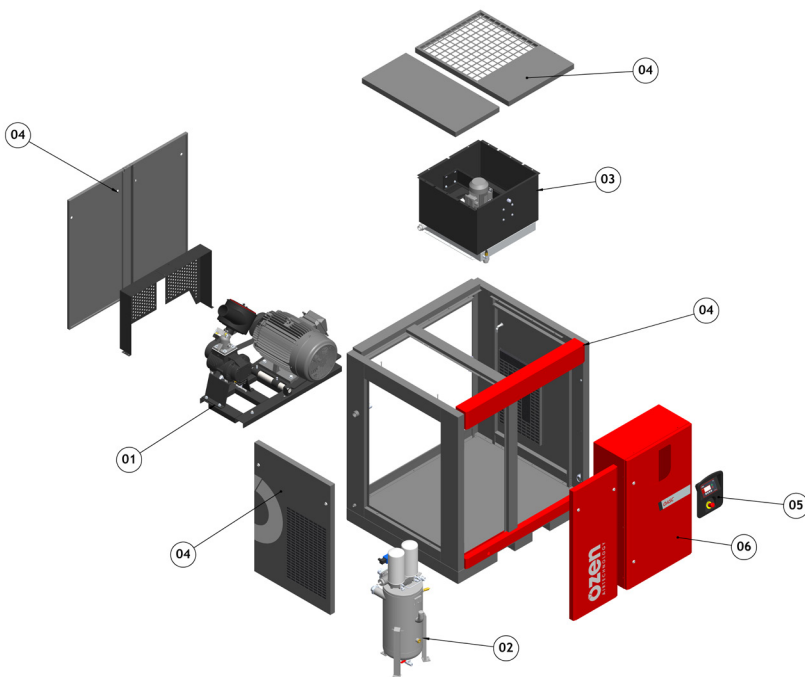
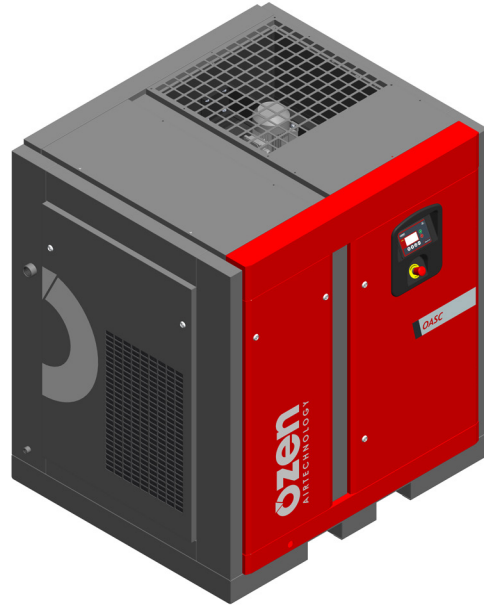

01	Motor & Air-End Group
02	Separator Tank
03	Cooling System
04	Compressor Cabinet
05	Operator Panel
06	Electric Cabinet

3.2 COMPONENTS

3.2.1 MOTOR & AIR-END GROUP

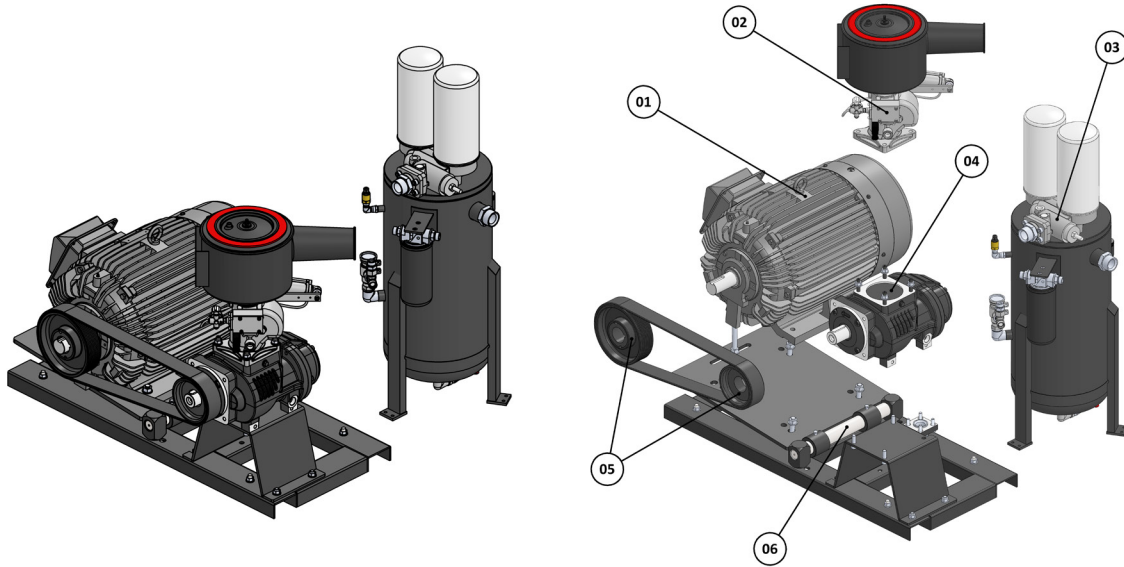

01	Electric Motor
02	Air Suction Group
03	Separator Group
04	Air-end
05	Belt and Pulley System
06	Air-end baseplate

The motor and air-end system of the compressor performs the compression of the air. Atmospheric air is pulled through the intake filter and valve by the air-end.

The air is then compressed by two rotors present in the air-end and sent to the separator tank for oil removal.

The air-end rotors are driven by an electric motor through a belt and pulley system.

The motor and air-end group is mounted on a base plate. Please refer to the parts manual for detailed pictures.

3.2.1.1 ELECTRIC MOTOR

The electric motor is selected by the appropriate voltage, frequency and motor speed according to the customer requirements.

The electric motor ensures the rotation of the rotors of the air-end and the production of compressed air.

All Ozen Air Technology compressors utilize electric motors that are listed as NEMA Premium Efficiency.

Motor efficiencies can be found in the Engineering Data Pages by compressor model.

The maintenance and replacement of the motor bearings are to be made in accordance with the maintenance chart.

THE SYSTEM OF COMPRESSOR

CHAPTER 3

3.2.1.2 AIR INTAKE GROUP

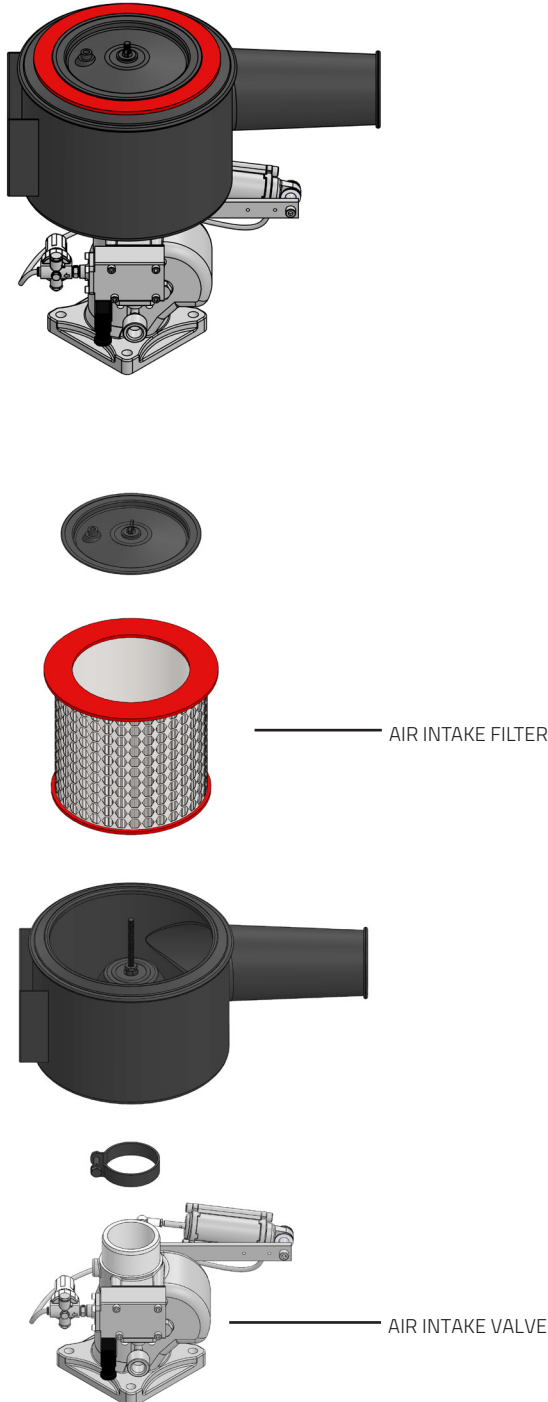

If the air ingested by the compressor contains dust or dust particles, the following may happen:

- Damage to the air-end rotors
- Reduced optimal working life of the oil.

The contaminated oil could also clog the oil separator and shorten its service life.

The first measure to combat these issues is to ensure that the air intake filter element is clean. If it is dirty, clean it with compressed air or replace the element.

Replacement of the air intake filter is carried out according to the maintenance schedule that you can find in the maintenance and cleaning methods in the "Section 5.1.4.4 Cleaning and Replacement of air intake filter".

Air Intake Valve

The air intake valve controls the amount of air that is ingested by the compressor and the amount of air compressed. When the air intake valve is fully open, the compressor operates at full load and produces compressed air at full capacity. When the air intake valve regulator valve is closed, the compressor runs idle and does not supply air to the system.

Installation of an inlet valve repair kit is to be performed according to the maintenance schedule.

3.2.1.3 SEPARATOR GROUP

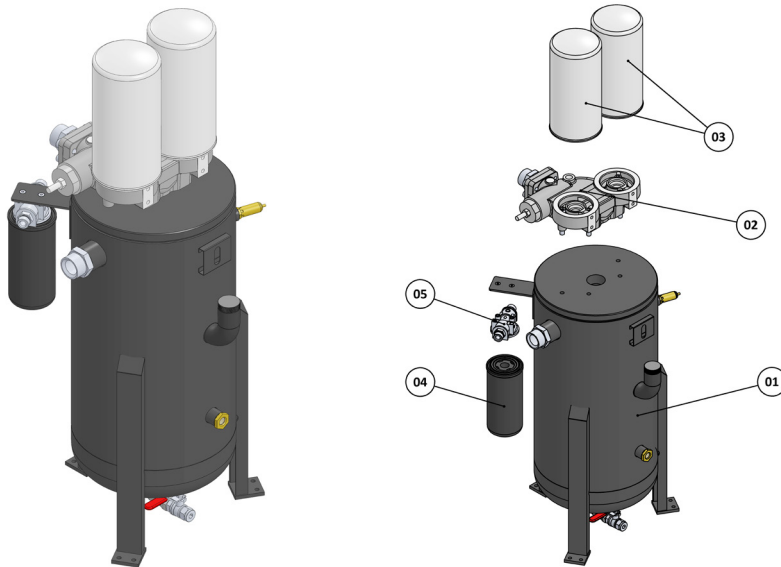

01	Separator Tank
02	Separator Combination Block
03	Separator
04	Oil Filter
05	Oil Filter Head

3.2.1.3.1 SEPARATOR TANK

A compressed air/oil mixture is delivered to the separator tank from the air-end. The separator tank acts as a holding sump for the oil.

Lubrication of the system is carried out with the internal pressure created by the minimum pressure valve in the separator combination block.

The oil in the separator tank first passes through the thermostatic valve. If the oil temperature is less than 131 ° F, the oil will then pass through the thermostatic valve to the oil filter to be cleaned. From there the oil will enter the air-end and finally back to the separator tank. If the oil temperature is higher than 131 ° F, the oil will pass through the thermostatic valve to the oil cooler before entering the oil filter.

The oil/air mixture coming out of the air-end is separated to a large extent with the help of gravity and a centrifugal effect in the separator tank.

The remaining oil is separated from the air in the separator element. Oil is returned to the air-end and the air passes through to the minimum pressure valve.

Separator tanks comply with ASME UM Stamp standards.

On the separator tank there is also a separator combination block and spin-on separator element and oil filter.

THE SYSTEM OF COMPRESSOR

CHAPTER 3

3.2.1.3.2 SEPARATOR COMBINATION BLOCK

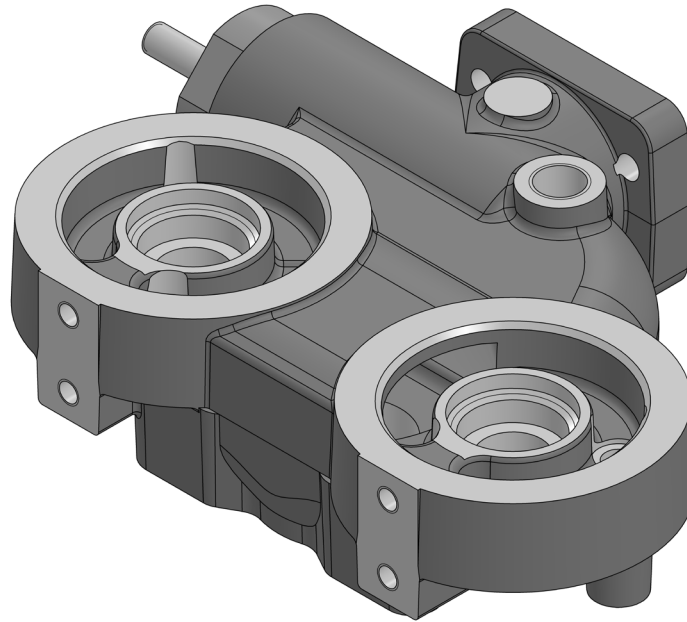

The separator combination block is a part that allows for the installation of spin-on type air separators and oil filters on a single structure. It also includes the minimum pressure valve, thermostatic valve, safety valve and scavenge line oil gauge. The safety valve and scavenge line oil gauge is replaced along with the minimum pressure valve and thermostat valve set during the course of maintenance.

In addition to its low cost and simple installation, it is a system that has a mono-block structure occupying less space, which minimizes the risk of leakage and allows for minimum pressure drop.

It is utilized from 4 kW up to 55 kW without issue.

Refer to the maintenance schedule for information on required maintenance to items contained in or on the combination block.

3.2.1.3.3 SEPARATOR

The oil separator element's primary function is to separate the remaining oil from the air that was not completed by the separator tank. Keep in mind that filtration is not the primary function of the separator element. Failure to replace the air filter and oil filter as recommended or contamination of the oil system will force the separator element to function as a mechanical filter and will shorten its life.

3.2.1.3.4 OIL FILTER

It is the filter used to clean the oil circulating in the compressor.

If the oil is not filtered properly, contaminants will enter the air-end and score the rotors and/or plug internal lubrication passages. Over time, this will shorten the life of the air-end, causing the compressor to become inoperable.

The oil filter is replaced according to the maintenance schedule.

Failure to use genuine Ozen parts and/or failure to replace the filter at the required interval in the maintenance schedule will void any warranty.

3.2.1.4 AIR-END

The air-end is equipped with a set of rotors, which are capable of compressing air up to 190 psi, dependent upon the set of pulleys used. Once the air is compressed, the air/oil mixture is delivered to the separator tank.

Never operate the compressor without the appropriate level of oil in the separator tank. This can lead to the air-end being severely damaged.

The air-end is to be maintained pursuant to the maintenance schedule.

3.2.1.5 BELT AND PULLEY SYSTEM

Pulleys are installed on the drive shafts of the motor and on the air-end. The connection of the pulleys to the shafts is made by the use of bushings. Pulleys in appropriate size and proportion should be used. These ratios and dimensions are determined by Ozen to adhere to performance and safety standards.

A high efficiency poly V belt is used in the belt and pulley system.

The pulleys are aligned with one another and connected by the use of a belt. A laser alignment tool or a straight edge may be used to check the alignment. Belt tension is determined and adjusted according to the description contained in Section 5.1.4.9 INSPECTION AND REPLACEMENT OF BELT

3.2.1.6 AIR-END BASEPLATE

The Motor & air-end Group baseplate manufactured from sheet metal plates is designed in the most appropriate way to ensure the healthy operation of the motor and air-end. The tensioning process of the belt and pulley system is carried out by means of the tensioning stud bolt in the Motor & air-end Group baseplate.

THE SYSTEM OF COMPRESSOR

CHAPTER 3

3.2.2 COOLING SYSTEM

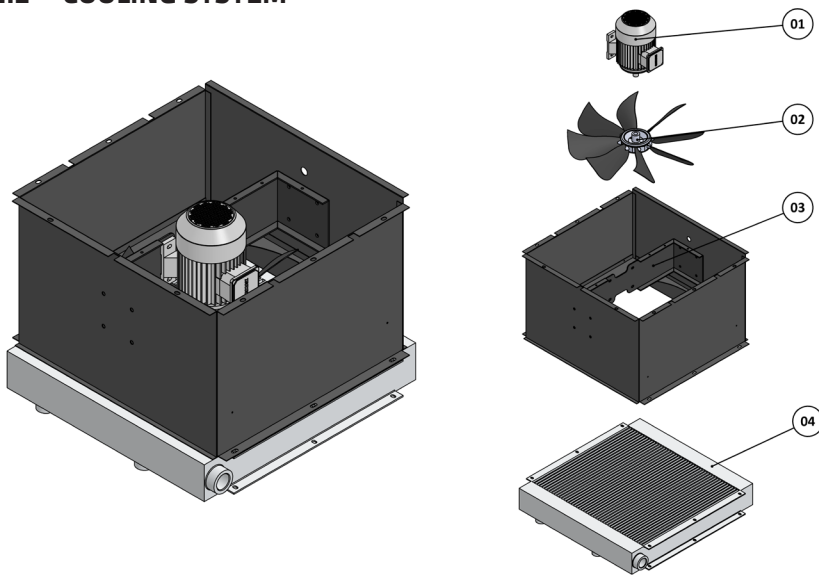

01	Fan motor
02	Axial fan
03	Ventilation hood
04	Cooler

Air and oil are cooled in the cooler in the cooling system.

The cooled oil is sent back to the system whereas the cooled air is sent out of the compressor.

3.2.3 OPERATOR PANEL

The compressors included in this manual use the Maestro 22 control panel.

Below you will find general information about Maestro 22.

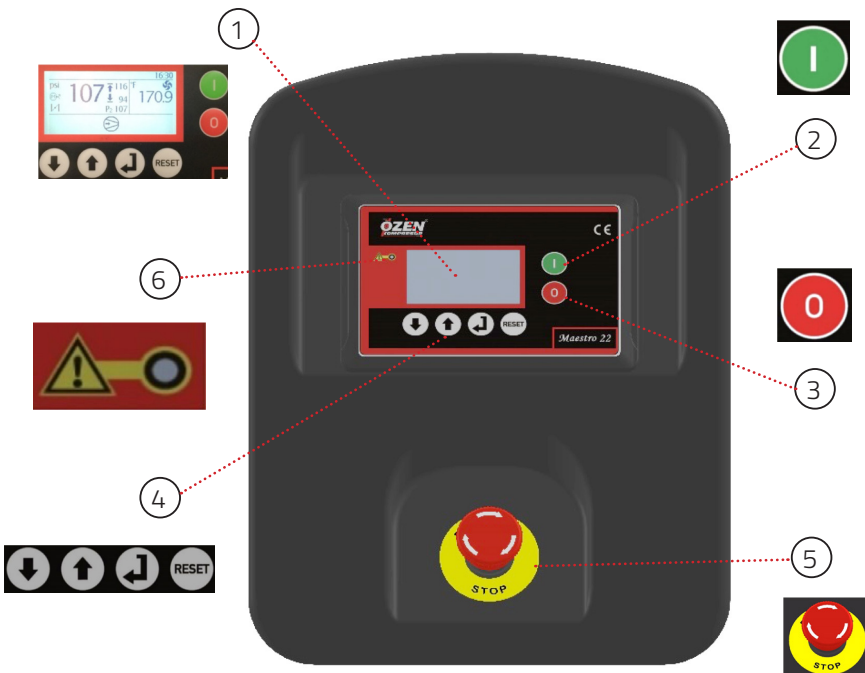

1 Digital Display: There are symbols such as pressure in the air tank, temperature value at screw oil outlet, error code in case of any faults, symbols such as the fan symbol while fan is running, texts and symbols.

2 Start button. It is the button used to start the compressor.

3 Stop button. It is the button used to stop the compressor.

4 Menu Keys: These keys are used for navigating through the controller menus. They are used when making any setting/parameter changes.

5 Emergency Stop: It is used to immediately stop the compressor in the case of any type of emergency. Do not use this button for normal stopping of the compressor.

6 Compressor malfunction LED. This LED is red in color.

The control panels employed in the compressors differ according to the operation of the compressor and the power rating of the compressor.

3.2.4 ELECTRICAL CABINET

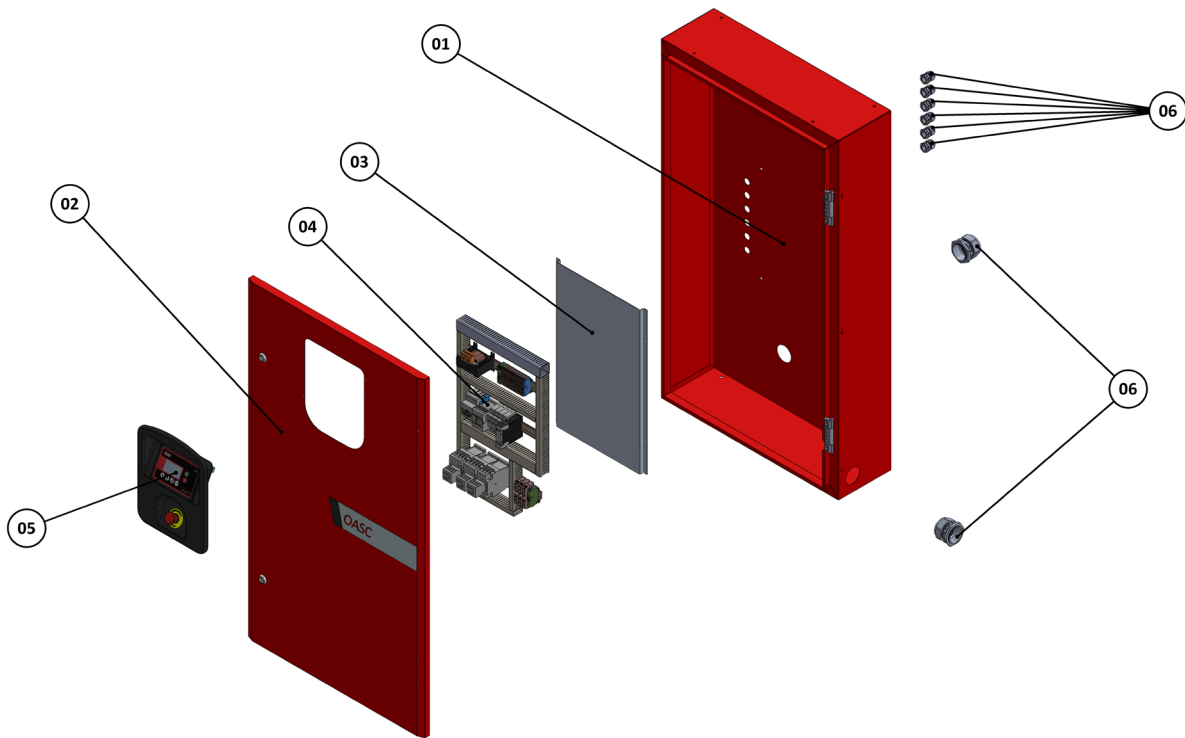

The control panels employed in the compressors differ according to the operation of the compressor and the power rating of the compressor.

The control panel is located on the electrical cabinet door. The connecting cables of the motor enter through the cable gland at the back of the electrical cabinet.

The connecting cables for the incoming power enter the electrical cabinet through the cable gland on the bottom right side of the electrical cabinet.

NEMA 1 cabinets are used as standard. Contact your local Ozen Distributor for higher-level electrical cabinets.

01	Electrical Cabinet
02	Electrical Cabinet Door
03	Electrical back-panel
04	Electrical Assembly
05	Control Panel (Controller)
06	Cable Glands

THE SYSTEM OF COMPRESSOR

CHAPTER 3

Electric panel in detail.

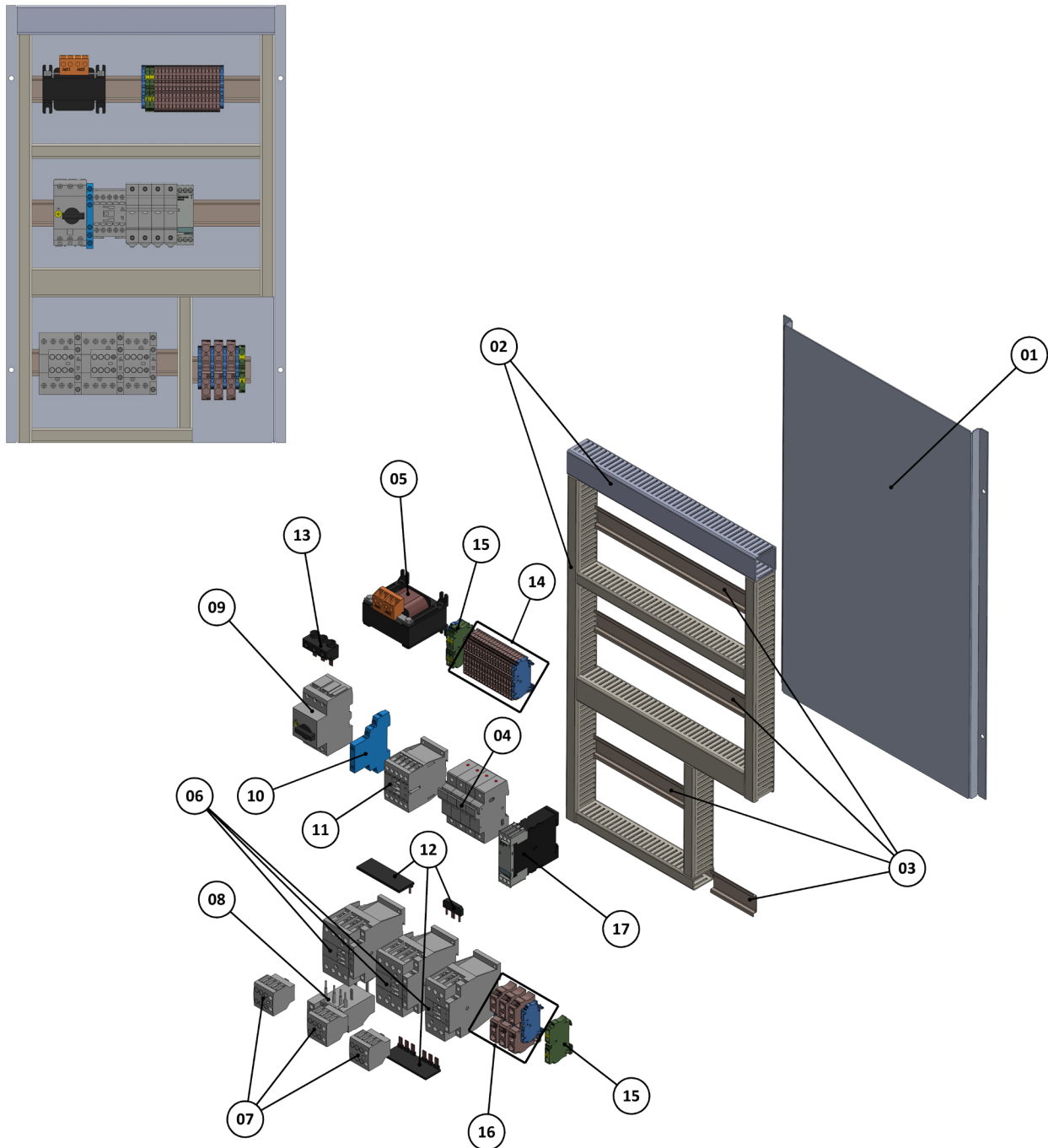

01	Steel back-panel
02	Cable tray
03	DIN rail
04	Fuse group
05	Transformer
06	Star-Delta motor contactors
07	Auxiliary contactors

08	Main motor thermal relay
09	Thermal switch
10	Auxiliary contact
11	Fan motor contactor
12	Star-Delta bus bars
13	Socket
14	Terminal blocks for control group (For Internal Wiring)
15	Terminal blocks for grounding
16	Terminal blocks for power group (For Field Wiring)
17	Motor Protection Relay

THE SYSTEM OF COMPRESSOR

CHAPTER 3

3.2.5 COMPRESSOR CABINET

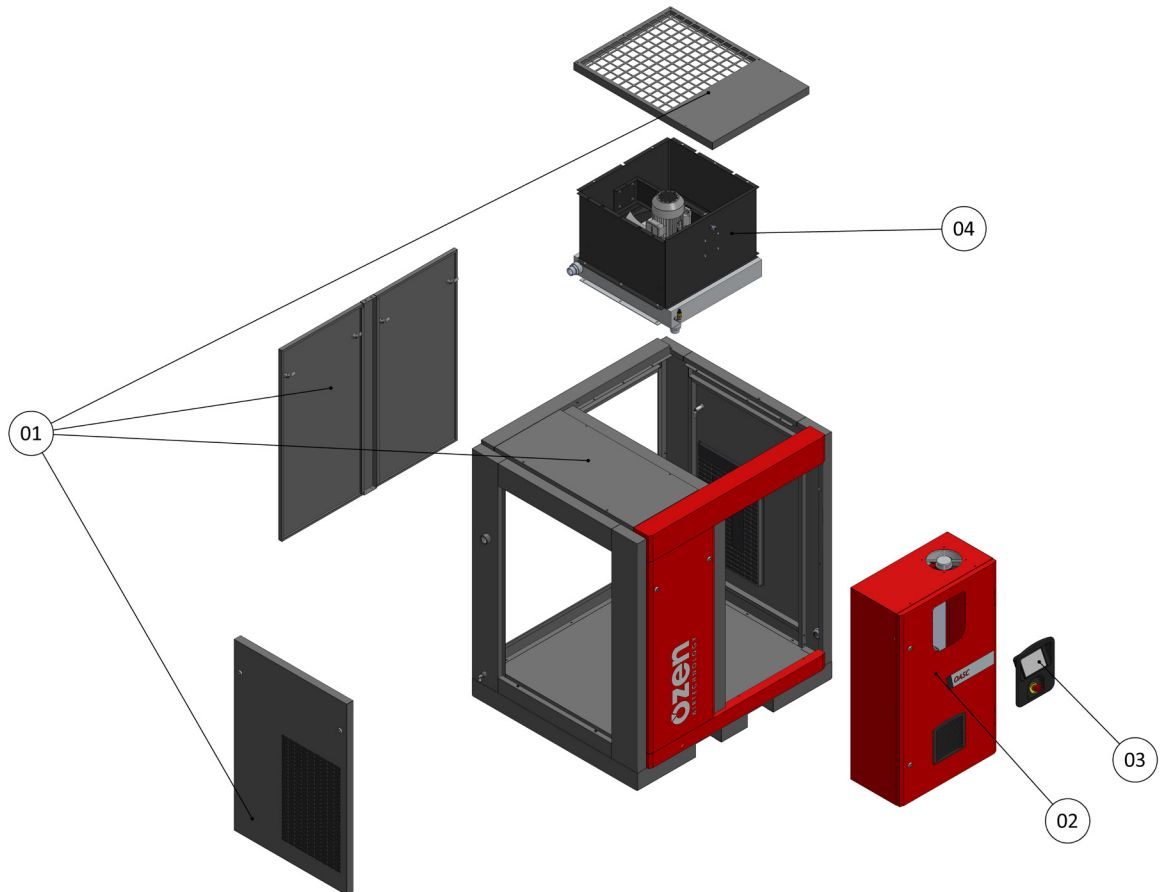

01	Compressor casing
02	Electrical cabinet for Compressor
03	Maestro controller
04	Compressor cooling system

HOW IT OPERATES

CHAPTER 4

4.1 GETTING STARTED

It is mandatory that this manual be read and fully understood in order to operate the compressor correctly and safely. Failure to do so may result in unsafe conditions, resulting in equipment damage and/or personal injury. All safety warnings and instructions must be strictly adhered to. If you have any questions after reading this manual, please contact your local Ozen Distributor



ATTENTION!

Before operating the compressor:

- Ensure that all cable connections are correct and properly tightened.
- Ensure that no foreign material was left in the machine or electrical cabinet.
- Ensure that ground connections were made and are tight.
- Ensure that piping connections are made and tight, including the installation of a discharge isolation valve and drip leg.
- Check the oil level.
- Verify that the belt guard is in place and all bolts are tight.
- Check compressor for oil leaks.

To start the compressor:

- ▶ Verify that the emergency stop button is not engaged. To do this, rotate the red button clockwise. If it was engaged, the button will pop up.
- ▶ Press the start button on the control panel.
- ▶ At this stage, do not forget to check motor rotation direction as per Section 2.5.3.
- ▶ If the compressor does not start, check the screen on the controller. It will show the reason for the failure to start by displaying an error code.
- ▶ If an error code is displayed, you can see the cause of the error in Section 4.2 Control Panel.



ATTENTION!

Never operate the compressor without the panels in place and guards installed.



Make sure that all covers are closed before operating the compressor!

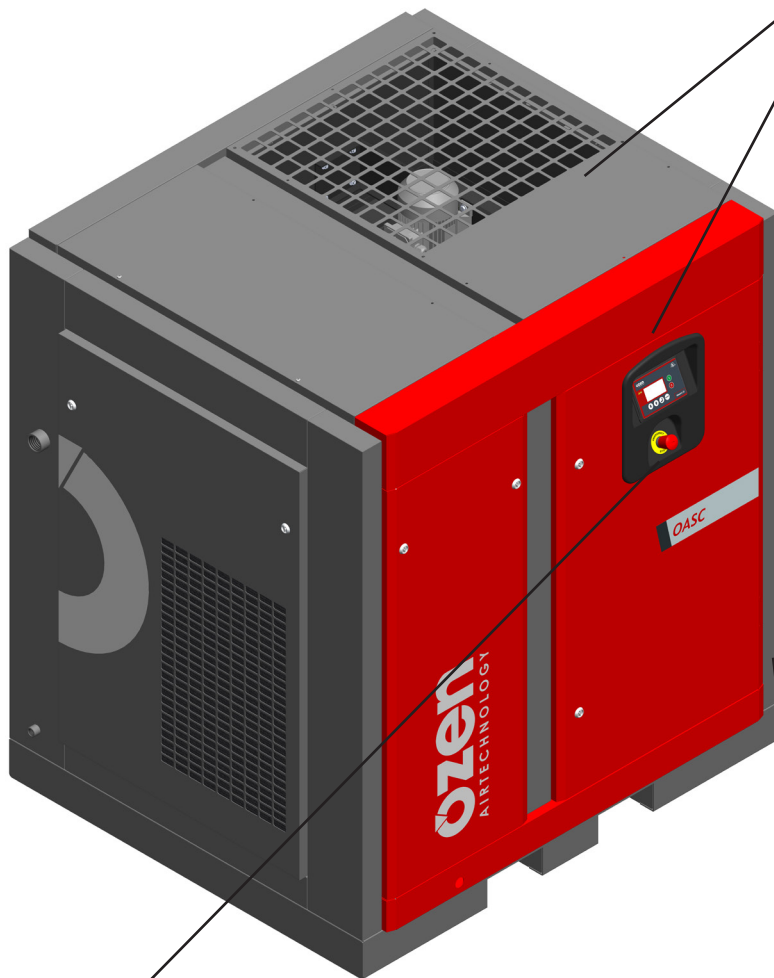

Ensure that the emergency stop button has been reset.

Verify that the electrical cables are of the proper size and secured properly to the gland.

HOW IT OPERATES

CHAPTER 4

Operation of the compressor is controlled by a Maestro 22 control panel.

The Maestro 22 control panel is a PLC based control unit, which is specially designed for the compressor industry.



ATTENTION!

Never operate the compressor without the panels in place and guards installed.

4.2 CONTROL PANEL

► Maestro 22

An overview of the appearance of the Maestro 22 control panel exterior is given in Section 3.2.3.

The Maestro 22 control panel is exclusively produced for Ozen Air Technology and is designed for easy control of the compressor. The Maestro 22, which is generally mentioned in Section 3.2.3. OPERATOR PANEL, will be described in detail in this section.

The Maestro 22 control panel:

- Controls the compressor.
- Shows the ideal service intervals for the compressor.
- Protects the compressor.

The Maestro 22 controller, along with the the sensors, overloads, etc., within the compressor, provides protections for the compressor. It will stop the compressor if an unsafe condition is sensed and will notify the user of the problem by displaying an error code. Never defeat any safety measures provided with this compressor and/or controller.

Alarms will stop the compressor, warnings will not. Always investigate the cause of alarms before attempting to re-start the compressor. Always obey warnings and take measures to clear them as soon as possible.

Please notify your local Ozen Distributor to schedule service when you see a maintenance warning on your Maestro 22 controller.



4.2.1 MAESTRO 22 CONTROL PANEL DISPLAY

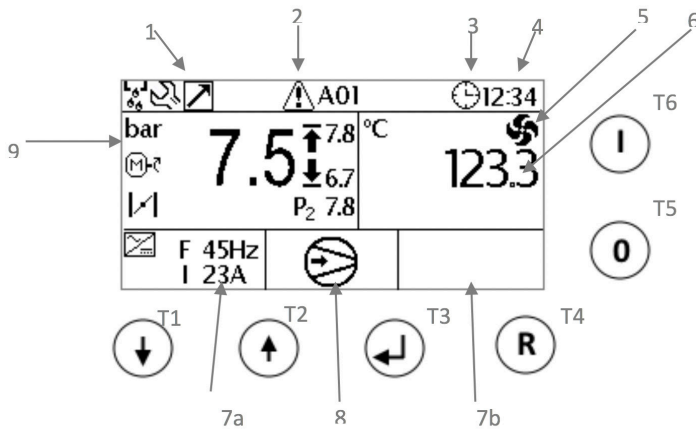

In case of alert, alert message appears on the bottom of the screen (7a, 7b, and 8).

Control of compressor is provided with 6 button as below (refer to screenshot above):

- T1, Decrease, Scroll Downward
- T2, Increase, Scroll Upward
- T3, Change or Confirm
- T4, Reset or Back
- T5, Stop Compressor
- T6, Start Compressor







MEANING OF ICONS







1. General icons:
 - I01, Condensate Drain
 - I02, Multi Unit Operation
 - I03, Master / Slave Operation
 - I04, Maintenance Messages
2. Alert or Maintenance Messages
3. Start / Stop by Timer Activation
4. Time (hour : minute)
5. Cooling Fan is Running
6. Compressor Temperature
7. Inverter Section: Data will populate once inverter becomes active. Dependent upon air temperature and operating pressure, data is shown on left side (7a) or right side (7b).
8. Shows compressor status. From I07 up to I13 they correspond to:
 - Compressor Off
 - Waiting for Security Timer
 - Pressure Set
 - Remote Start / Stop Control Active
 - Compressor On
 - Start / Stop is Waiting by Timer (In this case, screen shows day and time.)
 - Internal Pressure (P2 Parameter) is lower than AP4
9. Pressure Section:
 - Operating Pressure and Start / Stop Pressures
 - Auxiliary Pressure Converter (Activation Required)
 - Icon I17, Motor Operating
 - Icon I18, Solenoid Valve is Open







HOW IT OPERATES





CHAPTER 4

Images: Icons on Top of the Screen

I01		Condensate Drain Active
I02		Multi-Unit Operation Active
I03		Master/Slave Operation Active
I04		Maintenance Time
I05		Alarm
I06		Weekly Start / Stop Timer Active

I07		Compressor Off
I08		Waiting for Security Timer
I09		Pressure Setting, Discharge during operating or stand-by
I10		Remote Start / Stop Control Active
I11		Compressor On
I12		Stopped with Timer (Screen shows the next operation time)

I13		Internal Pressure P2 Too High
Images : Left Side=Pressure / Right Side=Temperature		
I14		Fan Operating
I15		PID and Ports 4/20mA Active
I16		Stop Pressure
I17		Start Pressure
I18		Motor Operating
I19		Compressor Operating in Loaded Condition

Menu Setting: Date, Time, Contrast, Measure Units		
I20		Measure Units Active
I21		Contrast
I22		Language
I23		Date and Time

HOW IT OPERATES

CHAPTER 4

4.2.2 MAESTRO 22 CODES AND DESCRIPTIONS OF ALARMS

The table of the error codes found on the left side of the Maestro 22 control panel is shown below. In the case of some of these errors, the compressor will not operate until the error is resolved. The following table describes which errors will shut down the compressor immediately and which will allow the compressor to run for 30 seconds before shut down. Please contact your local Ozen Distributor when you detect such errors.

Alarms that directly shut down the compressor

CODE	DESCRIPTION	CAUSE	ACTION
01	EMERGENCY STOP	Emergency stop button open (IN1)	Release emergency stop button
02	MOTOR OVERLOAD	Main motor thermal overload open (IN2.)	Motor thermal overload relay (1E4) malfunction. Contact your local Ozen Distributor.
03	THERMAL FAN	Fan Motor thermal overload open (IN3.)	Fan thermal overload relay (4E4) malfunction. Contact your local Ozen Distributor.
09	DRIVE FAULT	Input relay fault drive open/closed (alarm managed with input enabled, only (C21=1/2).)	Contact your local Ozen Distributor.
11	HIGH PRESSURE	Working pressure over set point of WP2.	Contact your local Ozen Distributor.
12	T. PROBE FAILURE	Air end temperature probe failure	Contact your local Ozen Distributor.
13	HIGH TEMP.	Air end temperature over set WT1	Contact your local Ozen Distributor.

14	LOW TEMP.	Air end temperature lower than set point of WT5.	Increase the ambient temperature over 14 °F. If problem persists, contact your local Ozen Distributor.
15	SEPARATOR	Delta P (internal pressure – working pressure) over shut off set point of AP1, once the timer C19.1 is over and air end temperature is over 45 °C (alarm managed when the aux pressure transducer is enabled into differential operation (C19=2).)	Contact your local Ozen Distributor.
18	POWER OFF	In case of power loss and compressor set to manual restart.	Check the power connection of compressor and restart compressor.
20	TEMP. MOTORE	PTC input open	Motor over temperature. Contact your local Ozen Distributor.
22	INPUT IN7	Parameter C12 = 3 (generic alarm)	Check the phase connection. If problem persists, contact your local Ozen Distributor.

Alarms that shut down the compressor after 30 seconds

26	PRESS. TRANSD. FAILURE	Working pressure transducer failure.	Contact your local Ozen Distributor.
27	AUX. TRANSD. FAILURE	Aux. pressure transducer failure.	Contact your local Ozen Distributor.
28	LOW VOLTAGE	Power supply to the controller lower than 9.5VAC and auto reset performed when the power goes over 10.6VAC. It is not visualized if it has been disabled in menu 4 of COMPRESSOR SETUP.	Contact your local Ozen Distributor.
29	SAFETY	Timer S—elapsed. This alarm is detected if the parameter, SAFETY, is set to YES.	Contact your local Ozen Distributor.
30	HIGH TEMP. WARNING	Air end temperature over set point of WT2.	Contact your local Ozen Distributor.
33	RS 485 FAILURE	Compressor start/stop is initiated via RS232 and the watchdog function is enabled (see MODBUS protocol communication.)	Contact your local Ozen Distributor.
60	INVERTER FAILURE	Shut down alarm detected from inverter via RS485 (managed by inverter connected via RS485 only (DRO>0).)	Contact your local Ozen Distributor.
62	COMMUNICATION INVERTER	No communication to inverter via RS485 (managed by inverter via RS485 only (DRO>0).)	Contact your local Ozen Distributor.

NOTE:

Every time a shut-down alarm is detected, LED DL1 is activated and the alarm message is stored into the alarm list. Once the cause of the alarm has been eliminated, push the button R to reset the message and start the compressor.

HOW IT OPERATES

CHAPTER 4

WARNINGS

CODE	DESCRIPTION	CAUSE	ACTION
30	HIGH TEMPERATURE WARNING	Air end temperature over set point of WT2.	Contact your local Ozen Distributor.
35	DATA LOST	Default data is lost or corrupt.	Contact your local Ozen Distributor.
37	MULTIUNIT FAILURE	No communication or master failure. Each slave works on its own.	Contact your local Ozen Distributor.
38	SEPARATOR	Delta P (internal pressure – working pressure) over warning set for AP2 when timer C19.1 is over and the air end temperature is over 113°F (45°C.) Alarm is managed by aux pressure transducer set for differential operation (C19=1)	Contact your local Ozen Distributor.
39	LOW VOLTAGE	Power supply to the controller is lower than 11.6VAC, automatic reset when the voltage rises over 12VAC.	Contact your local Ozen Distributor.
40	HIGH VOLTAGE	Power supply to the controller is over 14.5VAC.	Contact your local Ozen Distributor.
41	CLOCK FAILURE	Cycle the power to the compressor.	Check control panel. If problem persists, contact your local Ozen Distributor.
42	RS485 FAILURE	Master/slave communication is lost, auto reset when communication is restored.	Contact your local Ozen Distributor.
43	ORA LEGALE/SOLARE	Automatic change DLS / Summertime.	Update time in daylight saving time setting.
61	ALLARME INVERTER	Inverter failure detected in case of inverter connected via RS485 (managed in case of inverter communication via RS485 enabled (DRO>0))	Contact your local Ozen Distributor.

Table-3

4.2.3 MAESTRO 22 MAINTENANCE CODES

It is possible to reset the maintenance error codes while the compressor is running. You can reset the error code that appears on the display by pressing the ENTER key on the Maestro 22 control panel.

When you see maintenance error codes on the Maestro 22 screen, please contact your local Ozen Distributor. Adherence to the recommended compressor maintenance schedule in the Operator Manual is very important for the service life of the compressor and it should be completed without exceeding the maintenance time. Failure to perform the required maintenance will void any warranty and/or extended warranty.

CODE	DESCRIPTION	ACTION
S-A	Service Plan A	See COMPRESSOR MAINTENANCE PERIODS section in the Operator Manual.
S-B	Service Plan B	See COMPRESSOR MAINTENANCE PERIODS section in the Operator Manual.
S-C	Service Plan C	See COMPRESSOR MAINTENANCE PERIODS section in the Operator Manual.
S-D	Service Plan D	See COMPRESSOR MAINTENANCE PERIODS section in the Operator Manual.

Table-4

HOW IT OPERATES

CHAPTER 4

4.2.4 MAESTRO 22 DESCRIPTION OF STATUS IMAGES ON THE HOME SCREEN

POWER ON



The image on the left becomes active on the Maestro 22 HOME screen when the power is ON.

START THE COMPRESSOR

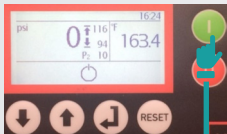

To start the compressor: You must press the Maestro 22 START button.

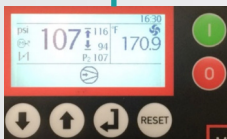

From this point, the HOME screen of the Maestro 22 will switch to the display on the left. The pressure value is for visual purposes only. Actual display value will be the compressor's discharge pressure.



ATTENTION!

Do not operate the compressor without the cabinet panels in place and guards installed.

STOP THE COMPRESSOR

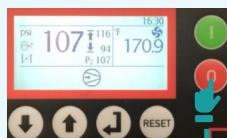

To Stop Compressor: When you press the stop button, the compressor will shut down. If the compressor is loaded at the time the stop button is pressed, it will unload. There are unload and safety timers involved, so the time that the compressor runs after pressing the stop button will vary, based upon the times set points of these timers (which are password protected.) By default, the compressor will run unloaded for between 10 and 130 seconds, dependent upon the timers being satisfied and their set points. If the compressor is unloaded when the stop button is pressed, the compressor will continue to run unloaded until the timers are satisfied.

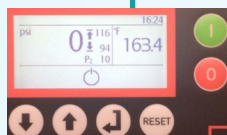

4.2.5 CONTROL PANEL USER SETTINGS

The Maestro 22 control panel is configured according to user requirements before the compressor leaves the Ozen factory.

The settings portion of the Maestro 22 control panel is password-protected, which are only known to Ozen Technical Staff and Service Personnel. Entry of incorrect settings can present dangers to both personnel and equipment by disabling safety devices and allowing higher than rated pressures. This is why passwords are not provided to the user.

The Maestro 22 control panel is programmed in the Ozen factory according to the technical information required by the user. The user cannot enter and make changes to all settings in the programmed Maestro 22 control panel. The settings that the user can see and change are limited.

USER HOME SCREEN OF MAESTRO 22

When the compressor gives an alarm, you will see the alarm code on the screen. Reference the Codes and Descriptions of Alarms section of the Operator Manual for more information on the alarm, as well as some helpful guidance on troubleshooting.

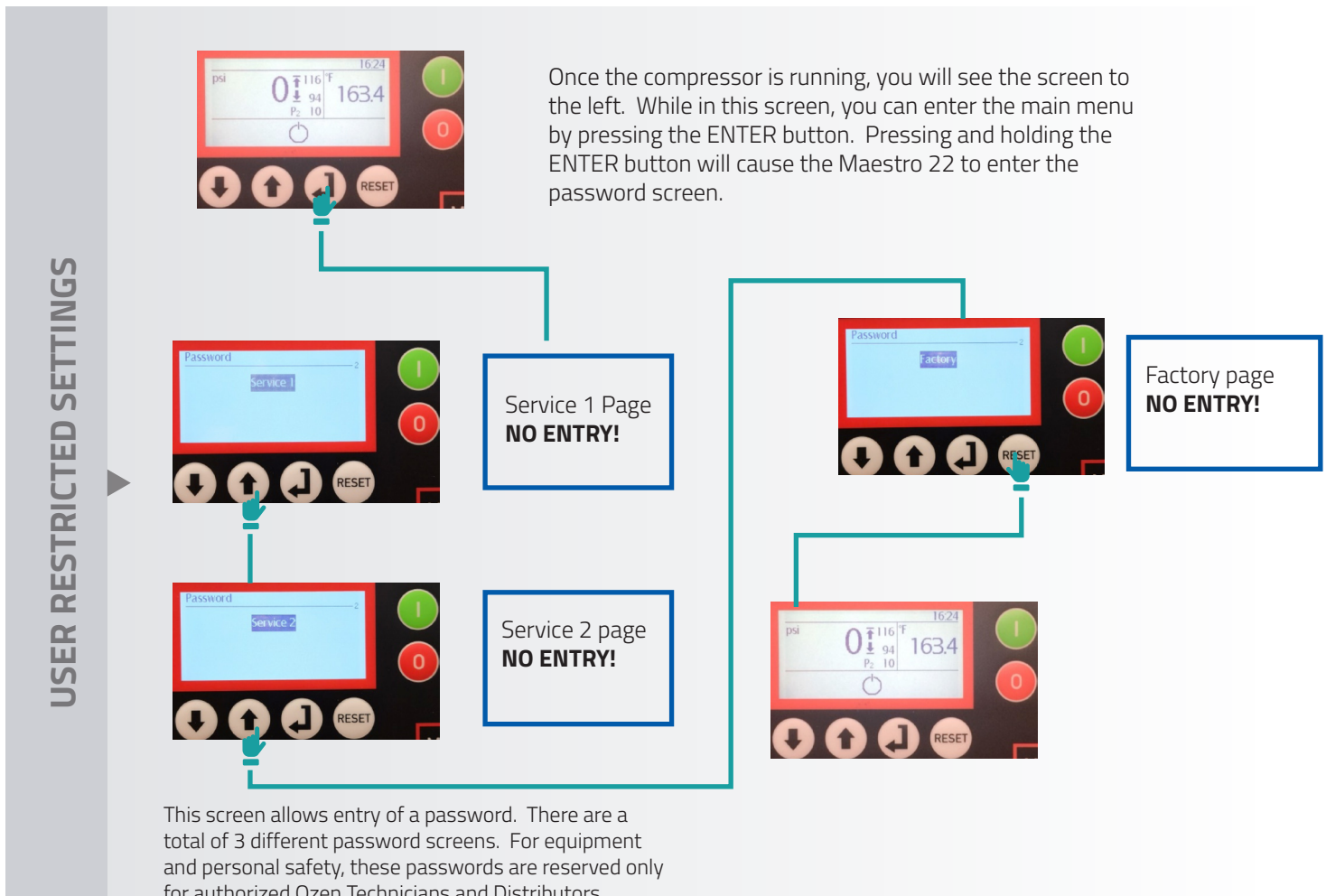

HOW IT OPERATES

CHAPTER 4

4.2.6 CONTROL PANEL OPERATION SETTINGS

HOME SCREEN

The main menu of Maestro 22 control panel is explained below:

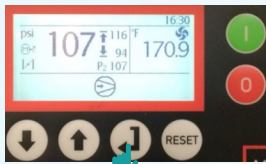

You can navigate through the menu via the ENTER button. After entering the main menu by pressing the ENTER button, the screen changes to what is shown to the left. In order to reach other lines in the menu, use the DOWN button.

PRESSURE SETTINGS

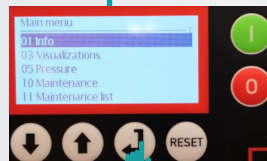

01-Information Menu: General information of the compressor will be shown in this menu.

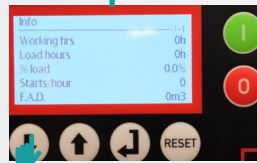

01-Information Menu

- Working hours (total run time)
- Loaded hours
- Percentage of time loaded
- Number of start per hour
- Flow rate
- Serial number
- Software

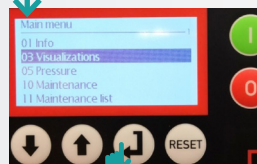
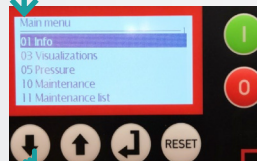

03- Screen Settings Menu: Maestro screen setting can be changed in this menu.

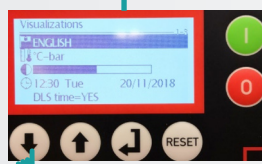

03-Screen Settings Menu

- Language of Control Panel
- Pressure and Temperature Units
- Screen Brightness
- Time and Date
- Daylight Saving Time

PRESSURE SETTINGS

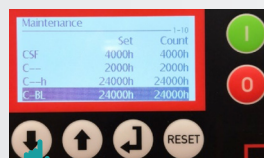
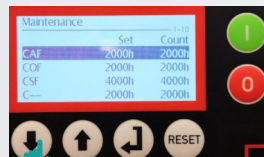
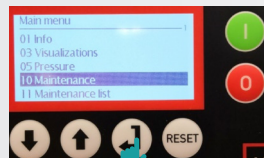
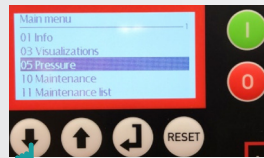
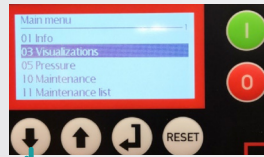

05- Pressure Menu: When a you enter this menu, nothing is shown. You cannot change the pressure value.

10- Maintenance Menu: Maintenance timers can be found in this menu.

10-Maintenance Menu

- CAF > Air Filter Change Time
- COF > Oil Filter Change Time
- CSF > Separator Change Time
- C-- > Oil Change Time
- C---h > Compressor Control Time
- C-BL > Bearing Control and Lubrication Time

HOW IT OPERATES

CHAPTER 4

PRESSURE SETTINGS

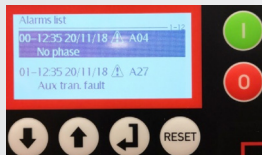
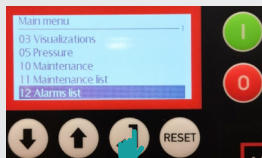
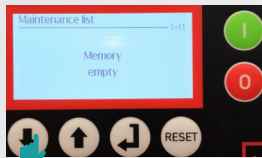
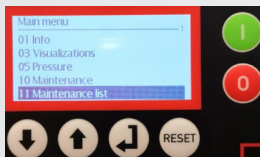
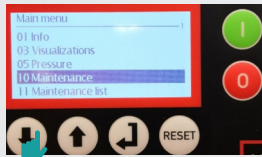

11- Maintenance List Menu: Maintenance history can be found in this menu.

12- Alarm List Menu: A list of past alarms can be found in this menu with details such as hour, date, and error code.

12- Alarm List Menu: The alarm codes and explanations can be found in section 4.2.2.

4.3 DAILY OPERATING INSTRUCTIONS

It is important to perform the daily checks on your compressor. This can prevent costly down-time of your system by uncovering potential issues before they become a problem.

Before operating your compressor:

- ▶ Check the amount of oil in the separator tank.

In the instance of low oil level, fill the compressor with the appropriate Ozen oil, following all safety precautions.

When you started the compressor:

- ▶ Make sure that there are no error codes on the control panel display.
- ▶ Check the pressure and temperature values on the control panel.
- ▶ Check for leaks and proper operation by observing the operation of the compressor for several minutes.
- ▶ Do not remove any components while the compressor is in operation.



ATTENTION!

When performing any operation on the compressor, stop the compressor and ensure that any residual air pressure has been relieved. Perform proper lock-out/tag-out procedure, wearing any required PPE per regulations. Always adhere to any local and national laws and safety regulations.



ATTENTION!

Do not operate the compressor with the covers open

MAINTENANCE

CHAPTER 5

5.1 PREVENTIVE MAINTENANCE INTERVALS

5.1.1 GENERAL DESCRIPTION

- ▶ The compressor maintenance and repairs must be carried out as described in this manual.
- ▶ Genuine Ozen parts must be used for maintenance and repairs.
- ▶ Appropriate and correct tools and implements should be used for maintenance and repairs.
- ▶ Disconnect the compressor from the power supply and always follow required lock-out/tag-out procedures and wear appropriate personal protective equipment (PPE) when performing any troubleshooting, maintenance, and/or repairs of the compressor. Always follow every safety precaution.
- ▶ Isolate the compressor from the pressure line by closing the compressor's air discharge valve and check that the compressor has an internal pressure of 0 Psi (no pressure) on the display of the Maestro 22 control panel.
- ▶ Do not clean with any flammable solvents or ones that leave any type of residue. Cleaning should be performed with a soft, lint-free cloth and mild cleaners.
- ▶ Care should be taken to avoid leaving loose bolts, nuts and glands in the compressor after maintenance and repair. Equipment used in maintenance and repair of the compressor (screwdriver, etc.) should not be forgotten inside the compressor.
- ▶ Before performing any type of service work, you must thoroughly read and understand this manual. Failure to do so may result in voiding the warranty, personal injury, and/or equipment damage.
- ▶ For cases in which there are any issues that you cannot solve, please contact your nearest Ozen Distributor.



ATTENTION!

Maintenance of the compressor by unauthorized personnel or improperly trained personnel will void any warranty and may also result in equipment damage and/or personal injury



5.1.2 DAILY MAINTENANCE

- ▶ Check the oil level daily.
- ▶ If the oil level is below 1/2 in the sight glass when the machine is off, add oil to bring it up to 1/2 in the sight glass before running the machine.
- ▶ If oil loss is frequent, there is likely a problem with the compressor. Refer to the Faults and Solutions chapter for possible causes and solutions. Contact your local Ozen Distributor for service or repair.
- ▶ In the case of air leakage, the efficiency of the compressor will decrease and the noise level will increase. Contact your local Ozen Distributor for service or repair.
- ▶ Check daily to ensure that there are no warnings and/or errors on the controller.
- ▶ Perform a visual check of the compressor for proper operation daily.
- ▶ Do not remove any components of the compressor while it is running. Always stop the compressor, relieve pressure, and observe proper safety precautions before making any adjustments while performing the daily checks.



5.1.3 WEEKLY MAINTENANCE

- ▶ Clean the air filter element with compressed air. Do not use any type of cleaning solvents.
- ▶ You should clean the cooler fins with compressed air.
- ▶ You should check the oil level.
- ▶ You should empty water accumulated in the air tank.
- ▶ Visually inspect the hoses for air and oil leaks.



MAINTENANCE

CHAPTER 5

5.1.4 COMPRESSOR MAINTENANCE INTERVALS

The maintenance intervals of the compressor are as shown in the table below.

Maintenance Intervals	Working Hours												SECTION
	2000	4000	6000	8000	10000	12000	14000	16000	18000	20000	22000	24000	
Air Filter Replacement	√	√	√	√	√	√	√	√	√	√	√	√	5.1.4.4
Oil Filter Replacement	√	√	√	√	√	√	√	√	√	√	√	√	5.1.4.3
Cooler Cleaning	√	√	√	√	√	√	√	√	√	√	√	√	5.1.4.10
Belt Tension Check	√	√	√	√	√	√	√	√	√	√	√	√	5.1.4.9
Electrical Connection Check	√	√	√	√	√	√	√	√	√	√	√	√	2.4
Oil / Air Leakage Check	√	√	√	√	√	√	√	√	√	√	√	√	5.1.2
Separator Replacement		√		√		√		√		√		√	5.1.4.3
Replacement of Cabinet Filters		√		√		√		√		√		√	5.1.4.12
Oil Plug O-Ring Replacement				√				√				√	5.1.4.2
Oil Change				√				√				√	5.1.4.2
Thermostatic Valve Maintenance Kit Replacement				√				√				√	5.1.4.7
Air Intake Valve Maintenance Kit Replacement				√				√				√	5.1.4.8
Minimum Pressure Valve Maintenance Kit Replacement				√				√				√	5.1.4.6
Oil Temperature Sensor Replacement												√	5.1.4.11
Belt & Coupling Replacement												√	5.1.4.9
Air-end and Motor Bearings Seal Rebuild												√	5.1.4.1
Solenoid Valve Diaphragm Replacement												√	5.1.4.8
Hoses Replacement												√	5.1.4.12
Service Plan Code	S-A	S-B	S-A	S-C	S-A	S-B	S-A	S-C	S-A	S-B	S-A	S-D	4.2.3

Table-5

The control panel alarm will display at each 2000 hour period for scheduled maintenance. This maintenance needs to be performed to maintain warranty and longevity of the life of the compressor. Please contact with your distributor for Ozen genuine service kits and parts.

5.1.4.1 AIR-END AND MOTOR

It is recommended that electric motor and air-end rebuilds should be carried out when they complete 24000 working hours. The front and rear bearings are replaced during the motor rebuild.

All bearings, seals and bearing houses are replaced during the air-end rebuild. At the same time, rotors should be checked to determine if there is any wear or not and, if required, subject to rebuild.



5.1.4.2 OIL SPECIFICATIONS, CHECK AND REPLACEMENT

Defined oil replacement intervals are valid for standard operating conditions and nominal operating pressure.

Exposure of the compressor to external pollutants, operation at high temperature, and/or operation with low duty cycles may dictate a shorter time interval between oil changes. Contact your local Ozen Distributor for a more personalized estimate based upon your site conditions and machine operation.

ZenLube Grades	46	68
Viscosity cSt @ 40°C	45	64
Viscosity cSt @ 100°C	6.5	8.57
Flash Point °F (°C)	445 (229)	451 (233)
Demulsibility, 130 °F, 30 Min	40/40/0	40/40/0
Copper Corrosion, 24 Hr	1a	1a
Rust Test: Distilled Water	Pass	Pass
Rust Test: Salt Water	Pass	Pass
Foam Sequence I, II, III	0/0/0	0/0/0

Table-6

ZenLube Troya Grades	46	68
Viscosity cSt @ 40°C	46.1	67
Viscosity cSt @ 100°C	6.7	8.7
Flash Point °F (°C)	450 (232)	478 (248)
Copper Corrosion	1a	1a
Rust Test: Distilled Water	Pass	Pass
Rust Test: Salt Water	Pass	Pass
Foam Sequence I, II, III	0/0/0	0/0/0

Table-7

ZenLube Troya FG Grades	46	68
Viscosity Index	105	103
Viscosity cSt @ 40°C	47	71
Viscosity cSt @ 100°C	7.0	9.3
Flash Point °F (°C)	450 (232)	465 (241)
Copper Corrosion, 24 Hr	1a	1a
Rust Test: Distilled Water	Pass	Pass
Rust Test: Salt Water	Pass	Pass

Table-8

MAINTENANCE

CHAPTER 5

Oil Level Check And Addition

The correct amount of oil is placed in the compressors before they are delivered to the customer. However, there may be a decrease in the oil amount during transportation and/or after a certain period of operation. Ensure the oil level is correct before start up.

- ▶ The oil level is checked by way of the oil level sight glass, which is located on the separator tank.
- ▶ The oil level must be at the mark provided in the middle of the oil level indicator when the machine is shut down and cooled down.
- ▶ The image showing the required oil level is below.



The required level of oil



ATTENTION!

The compressor must be stopped for a period of 10 minutes before checking the oil level.



• Oil Change And Addition



If a check of the oil level sight glass reveals no oil in the sight glass, then oil is required to be added to bring the level to half-way in the sight glass when the machine is shut down and cooled down.



MAINTENANCE

CHAPTER 5

The compressor oil must be changed at every 8000 working hours, whether the oil inside the separator tank is low or not. Every 8000 hours of operation, the compressor oil changes structurally and, if not replaced, the compressor's operating life is reduced. Compressors that are not serviced in accordance with the maintenance schedule will not be covered by warranty.

- ▶ Before changing the compressor oil, the compressor must be stopped and the internal pressure in the separator tank must be completely evacuated.
- ▶ The oil drain plug under the separator tank is to be removed and the valve opened for the oil in the system to be drained.

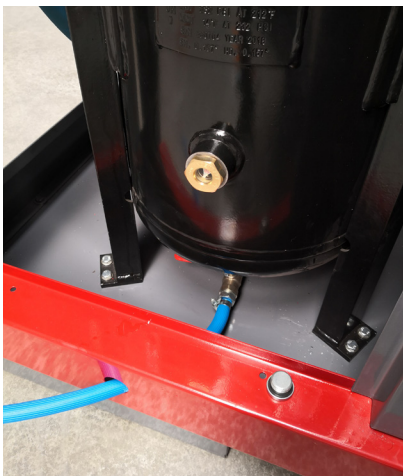

After removing the oil drain plug, tighten the hose nozzle (supplied with the compressor) to the valve. Then attach the hose to the hose nozzle and connect it with the clamp.



After connecting the hose with the clamp, open the valve and drain the oil until you are sure that there is no used oil left inside the separator tank.

- ▶ After the oil in the system has drained, the valve is closed and hose and the hose nozzle are removed. The drain plug is reinserted and tightened.
- ▶ The new oil is added by removing the oil fill plug on the separator tank.



- ▶ If there is an oil leak around the plug, the o-ring must be replaced.
- ▶ There is no need to replace the plug if there is a leak, just replace the o-ring.
- ▶ Filling can be completed with the use of a funnel.
- ▶ Refill the separator tank with the appropriate type of oil. If there is uncertainty as to what type of oil to use, please contact your local Ozen Distributor.
- ▶ After filling to the mark in the middle of the sight glass, the plug can be reinstalled and tightened.

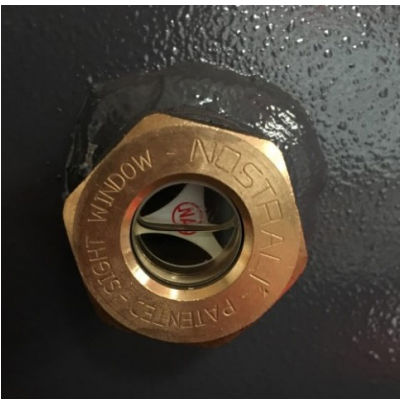

IMPORTANT!

Do not ever mix different types of oil. Doing so will void any warranty. If oils are accidentally mixed, do not run the machine. Contact your local Ozen Distributor immediately. Genuine Ozen oils and parts **MUST** be used in order for the warranty to remain intact.

MAINTENANCE

CHAPTER 5

5.1.4.3 OIL FILTER AND SPIN-ON SEPARATOR REPLACEMENT

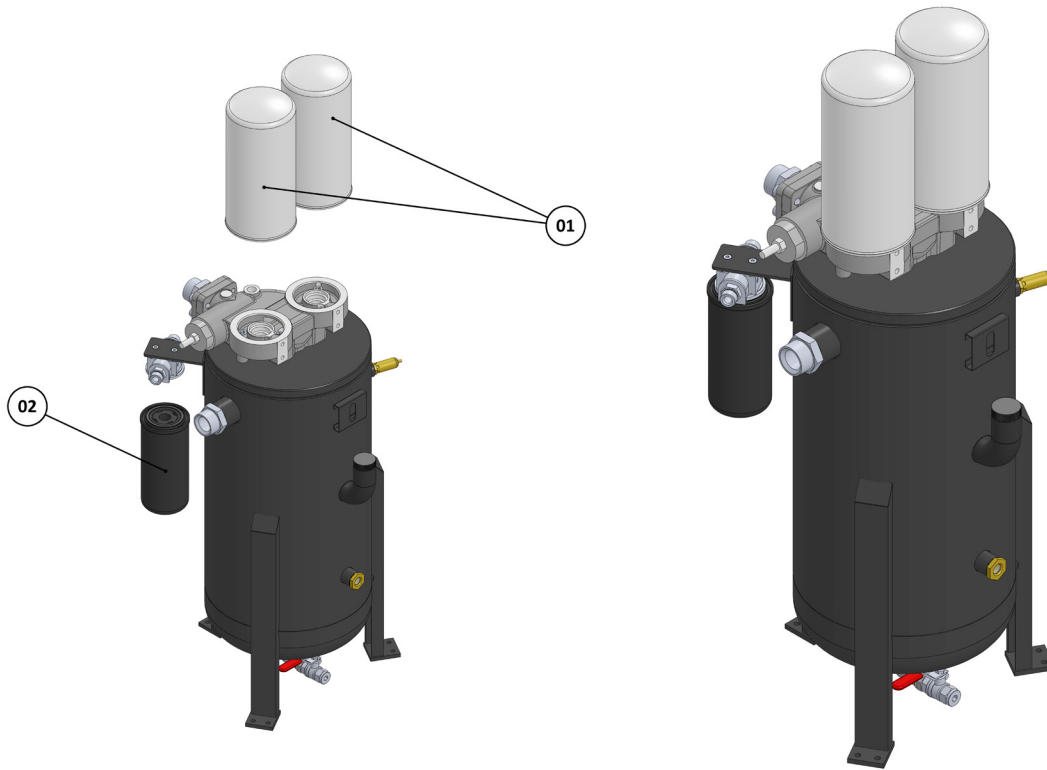

01 Spin-on Separator
02 Oil Filter

▪ Oil Filter Replacement



- ▶ You can see the oil change intervals in the “Oil specification check and replacement” section.
- ▶ After draining the oil, remove the oil filter by turning it counterclockwise with the help of strap-type filter wrench.
- ▶ There is no need to drain the oil if you are changing the oil filter.



- ▶ Clean the surface of any gasket residue remaining on the separator combination block after removing the used oil filter.
- ▶ Lubricate the surface of the seal on the new oil filter with new oil for easy installation.
- ▶ Tighten the new oil filter by hand until snug.

MAINTENANCE

CHAPTER 5

▪ Spin-on Separator Replacement



- ▶ Before changing the spin-on separator, stop the compressor and wait until the air in the system is completely drained.
- ▶ Remove the spin-on separator with the help of a strap-type wrench.



- ▶ Clean any remaining gasket material from the separator combination block.
- ▶ Lubricate the surfaces of the seal of the new spin-on separator.
- ▶ Manually tighten the new spin-on separator clockwise until snug.
- ▶ Never attempt to clean the spin-on separator. Always replace the separator with a new one.

5.1.4.4 CLEANING AND REPLACEMENT OF AIR INTAKE FILTER

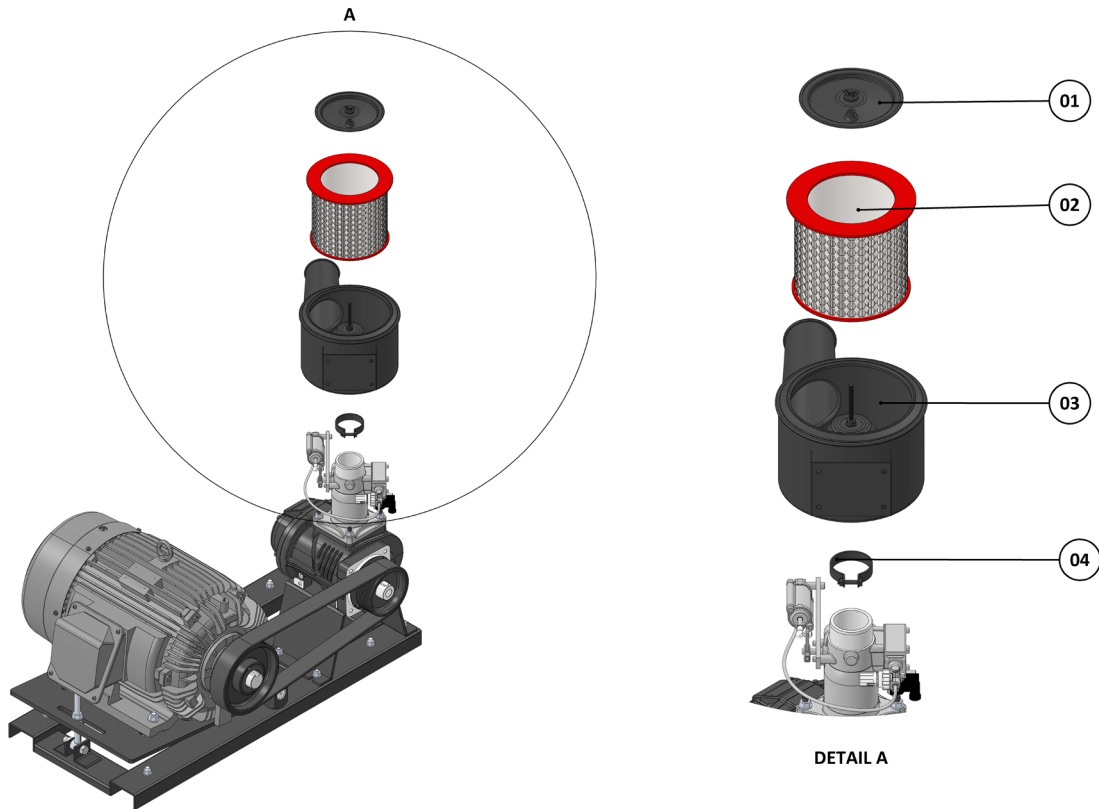

01	Cover of the air intake filter housing
02	Air intake filter element
03	Air intake filter housing
04	Clips

- ▶ Ensure that the compressor is completely switched off when replacing the air filter.
- ▶ Replacement of the air filter is important for more efficient operation of the compressor.
- ▶ The air filter may need to be replaced if the compressor fails to receive sufficient air.
- ▶ Contact an authorized Ozen Distributor when the air filter needs replacing.

MAINTENANCE

CHAPTER 5

5.1.4.5 INSPECTION AND REPLACEMENT OF SAFETY VALVE

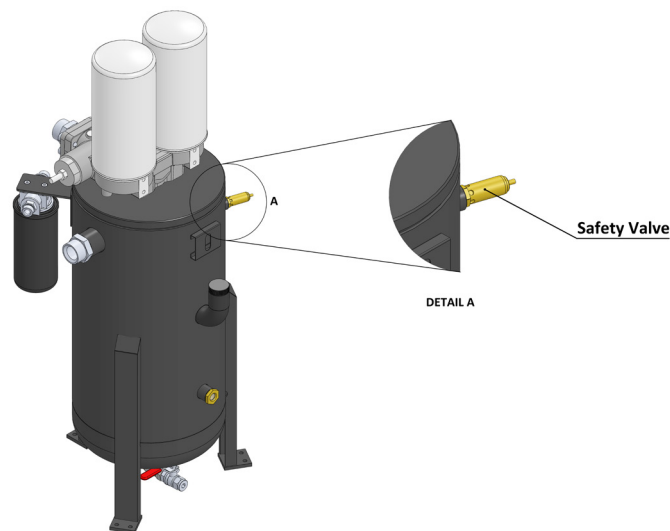

The safety valve is located/mounted on the separator tank of the compressor.

The presence of air and oil leaks generally means that the safety valve is defective.

The safety valve is not serviceable. If there is a malfunction, the valve must be replaced.

Replace the defective safety valve with a new one rated at the same specifications.

Faults that may be caused by the safety valve are outlined in "CHAPTER 6 / FAILURE AND SOLUTIONS".

5.1.4.6 REPLACEMENT OF MINIMUM PRESSURE VALVE

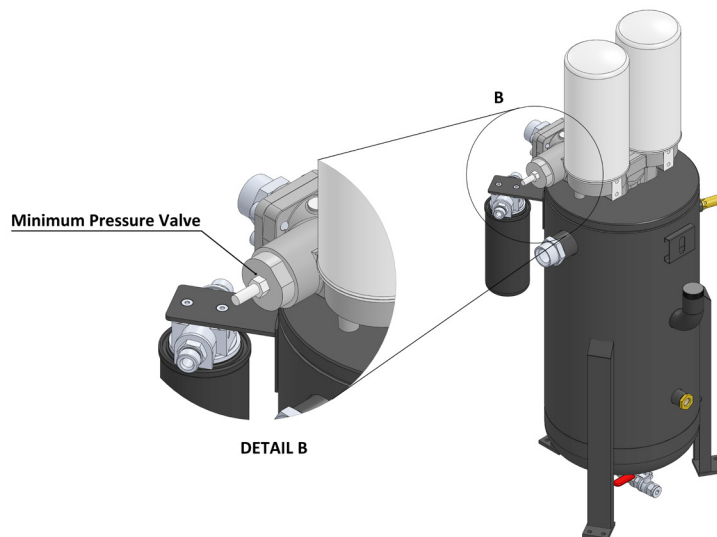

The minimum pressure valve is mounted inside the separator combination block.

The minimum pressure valve is set at 58 psi.

The minimum pressure valve can not be serviced. It should be replaced if there is any malfunction.

When replacing the minimum pressure valve, ensure that the machine is isolated and system pressure has been relieved.

Replace the defective minimum pressure valve with a new one rated at the same pressure.

Faults that may be caused by the minimum pressure valve are outlined in "CHAPTER 6 / FAILURES AND SOLUTIONS"

MAINTENANCE

CHAPTER 5

5.1.4.7 REPLACEMENT OF THERMOSTATIC VALVE

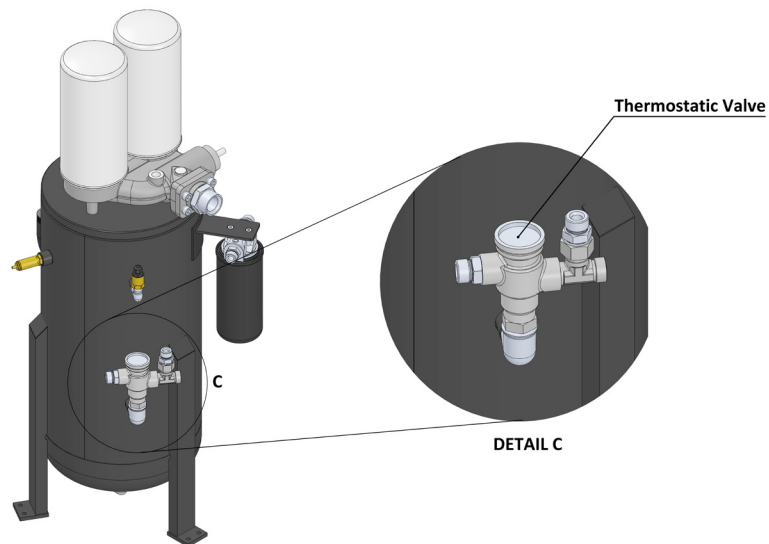

The thermostat is mounted on the separator tank of the compressor.,

The thermostat is a closed circuit unit, which is set to 160° F (71° C).

The thermostat can not be repaired so It should be replaced if there is any malfunction.

Contact an authorized Ozen distributor when any high temperature warnings appear on the Maestro 22.

Faults that may be originating from the thermostat can be seen in the "CHAPTER 6 / FAILURES AND SOLUTIONS".

5.1.4.8 CHECK AND REPLACEMENT OF AIR INTAKE VALVE (SUCTION FLAP)

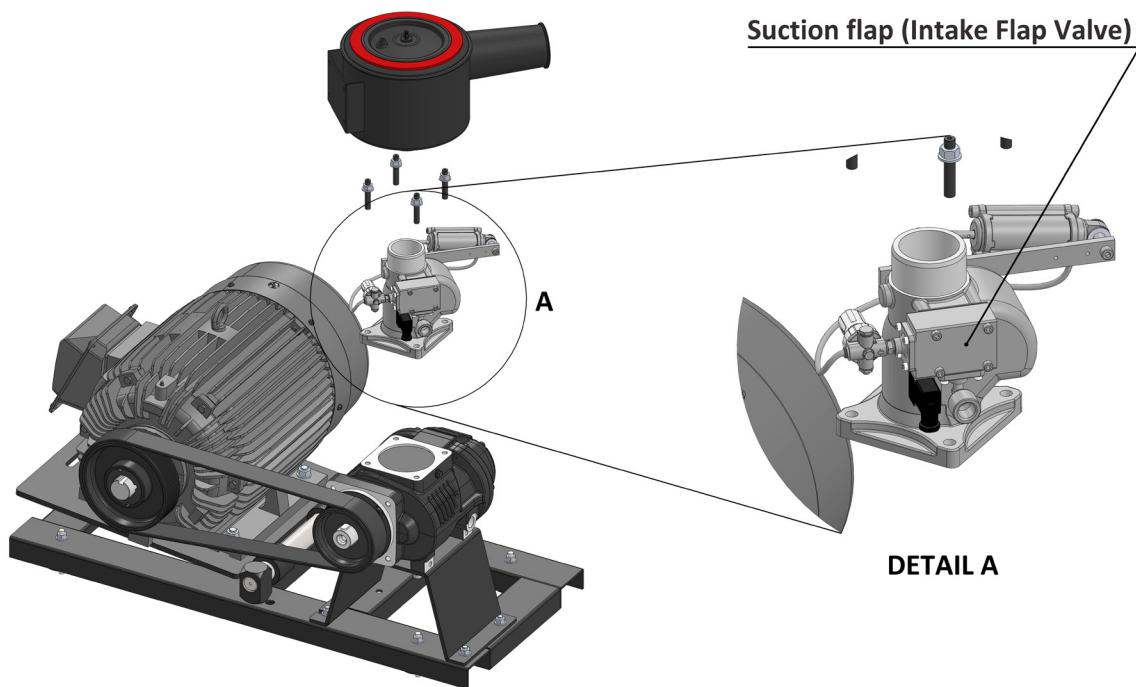

The inlet valve is located on the inlet port of the air-end and it is of a vertical design. The blow down solenoid is attached to the inlet valve and both valves are normally-open. The internal piston controls the amount of air allowed into the airend for compression and it has a internal non-return valve to prevent back-flow of air and oil when the machine is stopped.

The solenoid blow-down valve releases the internal pressure on the compressor when it is stopped or faults out on alarm. Solenoid valves are replaced with new ones during the 24,000 hour maintenance service.

The wear and tear of the air intake valve components depends on compressor applications and operating parameters.

Before the replacement, make sure that the compressor is stopped and the internal pressure has dropped to 0 psi as observed on the Maestro 22 screen.

If the compressor does not reach the desired pressure and the internal pressure does not drop with the compressor not operating there could be an issue with the air intake valve..

Malfunctions that may be originating from the inlet valve can be seen in the "CHAPTER 6 / FAILURES AND SOLUTIONS".

Use of original spare parts kits mentioned in the maintenance and troubleshooting instructions of Ozen Air Technology are recommended during valve inspection and routine maintenance operations.

MAINTENANCE

CHAPTER 5

5.1.4.9 INSPECTION AND REPLACEMENT OF BELT



The belt and pulley system must be inspected in accordance with the maintenance schedule.

If any of the following occur contact an authorized Ozen distributor for service.

- an abnormal sound
- the belt bounces while rotating
- black rubber dust particles

Inspection of the belts must be completed at the specified time intervals.

The alignment of the pulleys in the belt and pulley system are checked in our factory using a laser measurement instrument as seen in the figure.



Only Ozen OEM parts are suitable for belt and pulley replacement.

Please use the table below for required tension for each compressor according to kW and pressure rating.



MOTOR	Pressure PSI	Deflection (mm)	Deflection (inch)	Tension Meter Value (inch)
37 kW	100	8,95	0,35	1/2"
37 kW	125	7,12	0,28	1/4"
37 kW	150	7,02	0,28	1/4"
37 kW	190	6,31	0,25	1/4"
45 kW	100	7,9	0,31	1/4"
45 kW	125	7,9	0,31	1/4"
45 kW	150	7,74	0,30	1/4"
45 kW	190	7,63	0,30	1/4"

Table-9

The belt tension must be checked with a tension gauge (1/8 " interval) to ensure proper operation according to below description.

MAINTENANCE

CHAPTER 5

5.1.4.10 INSPECTION AND CLEANING OF COOLING GROUP



The cooler can become dirty and/or clogged over time. Clogged or contaminated coolers cannot properly fulfill their cooling function and the oil and air temperatures will increase. The cooler should be cleaned with compressed air once a week. The cooler will also be checked and serviced during every maintenance service. The cooler will be replaced if necessary.



ATTENTION!

Do not hold the air gun close to the cooler when cleaning the cooler with compressed air. If held too close to the cooler, the fins will bend. This will reduce the efficiency of the cooler.

5.1.4.11 OIL TEMPERATURE SENSOR REPLACEMENT



The oil temperature sensor is located inside the brass fitting attached to the oil outlet of the airend.

This temperature sensor loses its effectiveness over time and needs to be replaced.

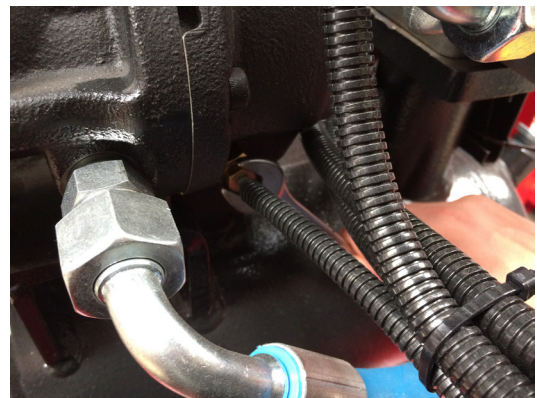

When the oil temperature sensor is being replaced, the nut of the brass fitting is removed and the sensor is taken out and replaced.

The oil temperature sensor should be changed every 24,000 hours as shown in the compressor maintenance chart.

5.1.4.12 MAINTENANCE AND REPLACEMENT OF CABINET FILTERS AND HOSES

The cabinet filters serve an important role in the internal cooling of the compressor. The cabinet filters must be cleaned using compressed air at least once a week. The compressor will overheat if the cabinet filters are not maintained or if there is an air restriction. In addition to the cleaning of the cabinet filters, they should be inspected and replaced by an authorized Ozen distributor every 4000 hours per the maintenance schedule.

Hoses should be checked by the user every week by opening the side panels. Contact an authorized Ozen distributor if any leaks are found.

Hoses must be replaced at the 24,000 hour maintenance period.

Hose maintenance and replacement should be completed by an authorized Ozen distributor.

FAILURES AND SOLUTIONS

CHAPTER 6

FAILURE	POSSIBLE FAILURE CAUSES	SOLUTION
Compressor not starting	Power failure	Check the phase cables and tighten if loose.
	Tripping of main and control fuses	Contact your local Ozen Distributor
	A break in a cable or loose connections.	Contact your local Ozen Distributor
	Tripping of thermal overload of motor or fan	Reset thermal overload of motor or fan.
	Compressor stopped due to any malfunction	Contact your local Ozen Distributor
	Re-starting the compressor immediately after a short time	The evacuation of the internal pressure has not yet been completed. After a short time the compressor will be ready for use again.
It takes too long for the compressor to start	Y-D changeover is not properly set	Contact your local Ozen Distributor.
	Low input voltage or fluctuating current	Check the electrical infrastructure at your facility and correct any faults.
	The ambient temperature is too low and the oil is too cold	Increase the ambient temperature.
	High oil viscosity	Use the appropriate oil type in your compressor. Change the oil of the compressor if it is time to replace the oil.
	Defective air intake valve	Contact your local Ozen Distributor
	Defective motor	Contact your local Ozen Distributor
Compressor fails to reach the desired pressure value	Leakage in the air line	Check the air hoses and the connections.
	Defective air intake valve	Contact your local Ozen Distributor
	Clogged air filter	Replace the air filter element.
	Insufficient capacity of the compressor for your system	Contact your local Ozen Distributor
	Defective Air-end	Contact your local Ozen Distributor
	Defective safety valve	Contact your local Ozen Distributor
	Improperly set motor thermal protection (overload)	Contact your local Ozen Distributor
	Improperly set pressure switch	Contact your local Ozen Distributor
Compressor exceeds the desired pressure value	Improperly set pressure values	Pressure values must be corrected via the control panel.
	Defective pressure sensor	Contact your local Ozen Distributor
Compressor fails to generate compressed air	Defective air intake valve	Contact your local Ozen Distributor
	Y-D system changeover time is not properly set	Contact your local Ozen Distributor
	Defective minimum pressure valve	Contact your local Ozen Distributor
	Defective Solenoid valve	Contact your local Ozen Distributor

FAILURE	POSSIBLE FAILURE CAUSES	SOLUTION
Compressor stops due to tripping of the motor thermal protection (overload)	Defective Air-end	Contact your local Ozen Distributor
	Improper thermal overload setting	Check the motor thermal overload setting and change if necessary.
	High pressure setting value	Check the pressure on the control panel. Correct if it is high.
	Low input voltage	Check the voltage at the power supply input of the compressor.
	Problem with motor	Contact your local Ozen Distributor
	Too high operating ambient temperature	Maintain the ambient temperature of the compressor to be between 32 °F (0 °C) and 115 °F (46 °C).
Compressor is reducing oil excessively.	Leakage in oil connection line	Contact your local Ozen Distributor
	Faulty separator	The separator element is required to be replaced.
Compressor stops due to the tripping of the thermal overload of the fan	The thermal overload setting is improper	Check the cooling fan thermal overload setting on the panel. Correct the setting as necessary.
	Problem with hot air outlet	Make sure that there are no obstructions in the hot air outlet. Clean the cooler fins if necessary.
	Cooling fan motor problem	Contact technical service.
	Too high operating ambient temperature	Maintain the ambient temperature of the compressor to be between 32 °F (0°C) and 115 °F (46 °C).
Contactor contacts are wearing too quickly	Y-D changeover time is too short	Contact your local Ozen Distributor
	Compressor is exposed to too frequent stop and restart operation.	Contact your local Ozen Distributor
	Low voltage at the input to the compressor	Check the electrical infrastructure of the facility.
	Use of improper parts	Contact your local Ozen Distributor
Temperature sensor or contact thermometer warning due to excessive temperature	System lacking oil	Check the oil level. Add oil if necessary.
	Clogged oil filter	The oil filter needs to be changed.
	Defective thermostat	Contact your local Ozen Distributor
	Clogged cooler	The cooler needs to be cleaned.
	Incorrect compressor room layout	The compressor must be installed in accordance with the installation layout instructions.

FAILURES AND SOLUTIONS

CHAPTER 6

FAILURE	POSSIBLE FAILURE CAUSES	SOLUTION
Compressor stops due to overheating	Incorrect compressor room layout	The compressor must be installed in accordance with the installation instructions.
	Extremely hot operating environment	Maintain the ambient temperature of the compressor to be between 32 °F (0 °C) and 115 °F (46 °C).
	Improper temperature setting	Contact your local Ozen Distributor
	System lacking oil	Check the oil level. Add oil if necessary.
	Clogged oil filter	The oil filter needs to be changed.
	Clogged air filter	Contact your local Ozen Distributor
	Clogged cooler	The cooler needs to be cleaned.
	Covers are open	The doors must be closed when the compressor is running.
Temperature increases when machine is unloaded.	There is blockage in the oil line or oil filter	Contact your local Ozen Distributor
Safety valve is opened	Defective safety valve	Contact your local Ozen Distributor
	Improper setting of the safety valve	Contact your local Ozen Distributor
	The operating pressure setting is wrong	Contact your local Ozen Distributor
	Compressor does not stop automatically	Refer to "Compressor exceeding the desired pressure value"
Oil In the compressed air	Defective separator	The separator element is required to be replaced.
	Clogged oil flow indicator	Contact your local Ozen Distributor
	High oil level	Check the oil level. Empty excess oil if necessary.
Oil loses its properties quickly	Failure to use recommended oil	You can get an oil recommendation by contacting your local Ozen Distributor
	High ambient humidity	The ambient humidity must be reduced.
	High ambient temperature	The ambient temperature must be reduced.
	Presence of gas, dust, etc. is contaminating the oil	The environment must be free of these substances.
Compressor does not stop automatically at idling	The idle time setting is not good enough	Contact your local Ozen Distributor
	Compressor re-loads in a very short time	Contact your local Ozen Distributor
Compressor blows down all the time	Defective solenoid valve	Contact your local Ozen Distributor
	Power failure in the supply line to the solenoid valve.	Check out the line and repair the required parts
Internal pressure does not relieve when stopping the compressor.	Defective air intake valve	Contact your local Ozen Distributor
	Defective minimum pressure valve	Contact your local Ozen Distributor
Phase protection warning	Incorrect connection of the phase cables	Two of the phase cables must exchange places

FAILURE	POSSIBLE FAILURE CAUSES	SOLUTION
Compressor is too noisy	Due to motor	Contact your local Ozen Distributor
	Due of pulley	Contact your local Ozen Distributor
	Due to pulley	Contact your local Ozen Distributor
	Due to connections	Contact your local Ozen Distributor
Occurrence of failures in belt and pulley system	Due to the non-alignment of the pulleys, buckling or worn sides of belt	Contact your local Ozen Distributor
	Buckling of the belt due to wrong belt and pulley profiles	Contact your local Ozen Distributor
	Belt gets twisted and is worn at the sides because of the worn pulley grooves.	Contact your local Ozen Distributor
	The belt is twisted due to excessive vibration	Contact your local Ozen Distributor
	The belt is twisted due to foreign particles inside the pulley grooves.	Foreign particles are required to be removed
	Wear of belt edges due to too high initial torque	Contact your local Ozen Distributor
	Wear of the belt edges due to incorrect pulley groove angle	Contact your local Ozen Distributor
	Belts becomes sticky due to contact with oil or other chemicals	The belt and pulley system will be cleaned with cleansing agents
	Expansion of the belt	Contact your local Ozen Distributor.
	Belt rupture/breakage	Contact your local Ozen Distributor.
	Formation of cracks in the belt	Contact your local Ozen Distributor.
	Improper belt tension	Contact your local Ozen Distributor.

Table-10

TECHNICAL DATA

CHAPTER 7

7.1 COMPRESSOR NAMEPLATE

Ozen Compressed Air Technology and Equipment LLC. 4205 Golf Acres Drive, Charlotte, NC 28208, USA Office : (704) 660 0334 info@ozenairtech.com			
MODEL		SERIAL NUMBER	Manufacturing Year
③		④	⑤
WORKING PRESSURE (PSI-bar)		CAPACITY (Cfm-m ³ /min)	
⑥		⑦	
MOTOR POWER (kW-hp)		MOTOR SPEED (rpm)	MAIN SUPPLY
⑧			⑨
DIMENSIONS (inch)	WEIGHT (lbs)	OUTLET CONNECTION	PACKAGE AMPS
⑩	⑪	⑫	⑬

- 01 Manufacturing Company Information and address
- 02 Manufacturing Company Logo
- 03 Compressor Model
- 04 Compressor Serial Number
- 05 Year of manufacture of compressor
- 06 Compressor Output Pressure
- 07 Compressor Output Pressure
- 08 Power of Main Motor Employed in the Compressor
- 09 Mains Voltage
- 10 Compressor Dimensions
- 11 Compressor Weight
- 12 Compressor Air Outlet Size
- 13 Package Amps

7.2 COMPRESSOR DATA

MODEL kW HP	kW/HP	OASC 37 37 kW 50 HP				OASC 45 45 kW 60 HP			
MAX. OPERATING PRESSURE	PSI	100	125	150	190	100	125	150	190
	BAR	6.9	8.6	10.0	13.1	6.9	8.6	10.0	13.1
CAPACITY (FAD)	Cfm	211,1	190,7	175,8	148,5	272,0	247,2	229,5	195,9
	m ³ /min	5,98	5,40	4,98	4,20	7,70	7,00	6,50	5,55
MOTOR SPEED	rpm	3600				3600			
AIR INPUT TEMPER- ATURE	°C	20				20			
	°F	68				68			
INLET ABSOLUTE AIR PRESSURE	BAR	1				1			
	PSI	14.5				14.5			
SOUND LEVEL	(db)	75				75			

Table-11

TECHNICAL DATA

CHAPTER 7

7.3 POWER CABLE DIMENSIONS

 WIRE SIZE		60°C (140°F)		75°C (167°F)		MAIN MOTOR POWER	MAIN MOTOR POWER
						(460 V)	(208V - 230V)
AWG	mm ²	Copper	Aluminum	Copper	Aluminum	kW	kW
12	3.3	20	15	20	15	4	-
12	3.3	20	15	20	15	5.5	-
10	5.3	30	25	30	25	7	-
10	5.3	30	25	30	25	11	4
8	8.4	40	30	50	40	15	5.5
8	8.4	40	30	50	40	18.8	7
6	13.3	55	40	65	50	22	11
6	13.3	55	40	65	50	30	15
4	13.3	70	55	85	65	37	18.8
4	21.2	70	55	85	65	45	22
1	42.4	110	85	130	100	55	30
1/0	53.5	-	-	150	120	75	-
1/0	53.5	-	-	150	120	90	-
3/0	85	-	-	200	155	110	-
4/0	107.2	-	-	230	180	132	-

Table-12

Cable dimensions in the table are in accordance with UL standards. These measurements are valid for cables having a length of up to 50ft (15m.) For connections greater than 50ft, the cable selected must be one size higher.

NOTE: Cable and fuse sizes are a recommendation. Always size electrical components per local codes and regulations.

7.4 PRELIMINARY FUSE ON SITE

PRELIMINARY FUSE ON SITE-PFS (Amps)	
kW	460 V
37	80
45	100
55	125
75	150
90	170
110	250

Table-13

7.5 FUSE SPECIFICATIONS AS PER COMPRESSORS

 208 - 230 VOLT COMPRESSOR FUSE CURRENTS (AMPS)						
kW	F1 (Time Delay)	F2 (Time Delay)	F3	F4	F5	F6
4	1	1	6	2½	10	10
5.5	1	1	6	2½	10	10
7	1	1	6	2½	10	10
11	1	1	6	2½	10	10
15	1	1	6	2½	10	10
18.5	1	1	8	2½	16	16
22	1	1	8	2½	16	16
30	1	1	8	2½	16	16

Table-14

 460 VOLT COMPRESSOR FUSE CURRENTS (Amps)							
kW	F1 (Time Delay)	F2 (Time Delay)	F3	F4	F5	F6	F7
4	1	1	6	2½	3½	3½	10
5.5	1	1	6	2½	3½	3½	10
7	1	1	6	2½	3½	3½	10
11	1	1	6	2½	3½	3½	10
15	1	1	6	2½	3½	3½	10
18.5	1	1	8	2½	5	5	16
22	1	1	8	2½	5	5	16
30	1	1	8	2½	5	5	16
37	1	1	10	2½	-	-	-
45	1	1	10	2½	-	-	-
55	1	1	12	2½	-	-	-
75	1	1	12	2½	-	-	-
90	1	1	12	2½	-	-	-
110	1	1	16	2½	-	-	-
150	1	1	16	2½	-	-	-

Table-15

TECHNICAL DATA

CHAPTER 7

7.6 CONTACTOR CURRENT DRAW BY COMPRESSOR SIZE

CONTACTOR CURRENT (AMPS) 460 VOLT COMPRESSOR			
KW	K1	K2	K3
4	9	-	-
5.5	12	-	-
7	12	12	7
11	15	15	9
15	17	17	12
18.5	25	25	15
22	32	32	17
30	38	38	25
37	40	40	32
45	50	50	38
55	65	65	40
75	80	80	65
90	95	95	72
110	115	115	80
132	150	150	95

Table-16

Ozen Compressed Air Technology and Equipment, LLC.
4205 Golf Acres Drive Charlotte NC 28208
Office (704) 660-0334
E-mail info@ozenairtech.com

