

# HelixDrive

## Ultra-Compact, Oil-Free Dry Screw Vacuum Pump

**HelixDrive** is an ultra-compact, oil-free dry screw vacuum pump. Its unique coaxial design, with an integrated motor, enhances both efficiency and reliability. Its proprietary coating protects the pump from the most demanding industrial applications. Ideal for harsh applications where oil is not tolerated.



- ▶ **Oil Free Operation**  
Ideal for harsh applications where oil is not tolerated.

- ▶ **Temperature Management**  
Our temperature management system is optimized for the most effective cooling. Our larger pumps are water-cooled to enhance the performance of the pump while our smaller pumps are air cooled for easy operation.

- ▶ **Energy Efficiency**  
Equipped with Permanent Magnet motor, HD20 and HD40 are the most efficient dry pumps in their class.

- ▶ **Water Vapor Handling**  
HelixDrive pumps are robust and durable. They have excellent moisture handling capacities.

- ▶ **Compact Design**  
As one of the most innovative designs, this dry screw pump delivers fast pumping speed in an ultra compact package.



**HD20**



**HD80**

# HelixDrive

Ultra-Compact, Oil-Free Dry Screw Vacuum Pump

SPEC		HD8	HD20	HD40	HD80	HD100
Pumping Speed(60Hz)	m <sup>3</sup> /h(CFM)	8	20 (12)	32 (19)	80 (47)	100 (59)
Ultimate Pressure	mbar	1.0x10 <sup>-2</sup>	1.0x10 <sup>-2</sup>	1.0x10 <sup>-2</sup>	3.0x10 <sup>-2</sup>	3.0x10 <sup>-2</sup>
	Torr	7.5x10 <sup>-4</sup>	7.5x10 <sup>-4</sup>	7.5x10 <sup>-4</sup>	2.2x10 <sup>-2</sup>	2.2x10 <sup>-2</sup>
Gas purge	Dry Nitrogen/Dry Compressed Air	slm	/	0~100	0~100	0~180
	Pressure	Mpa	/	0.04~0.07	0.04~0.07	0.015~0.02
	Joint	/	Quick joint for air pipe Φ6mm			
Rated power	kW	1.8	1.8	1.8	3	3
Current at Ultimate Pressure	A	6	7	8	3	4
Peak Current	A	13	13	13	6	7
PID Functions		Yes				
Analog Input		Yes				
Communication Function		MODBUS-RTU				
Inlet/Outlet		KF25/KF16	KF25	KF25	KF40	KF40
Water Vapor Treatment Capacity	g/h	135	200	200	800	800
Cooling Mode		Air Cooling			Water Cooling	
Ambient Temperature		5°C~40°C				
Noise	dB	≤58	≤60	≤60	≤65	≤65
Weight	lbs	83.7	105.8	105.8	452	452
Dimensions (L*W*H)	in	20.5x11.8x12.6	23.6x11.8x12.6	23.6x11.8x12.6	35.4x18.3x21.6	35.4x18.3x21.6

## Dimensions

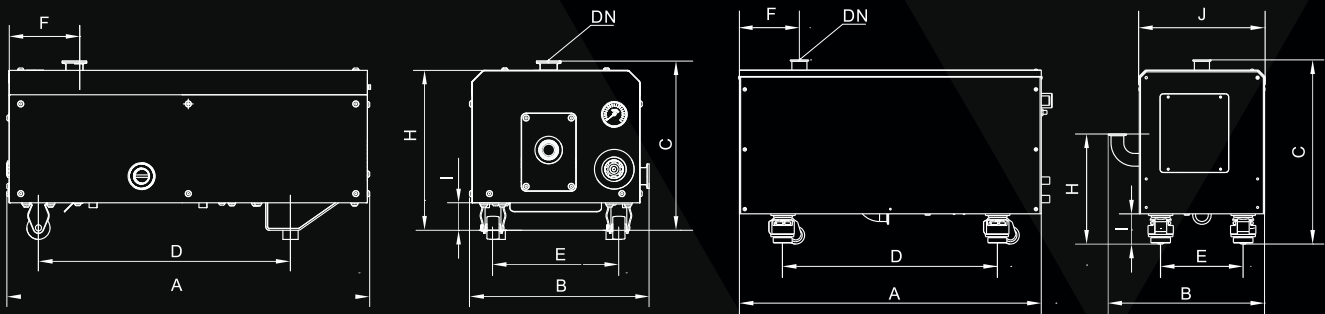

Unit: inch

Model	A	B	C	D	E	F	H	I	J	Inlet/Outlet
HD8	20.5	11.8	12.6	13.5	8.2	4.2	11	2.3	/	KF25
HD20	23.6	11.8	12.6	16.3	8.2	4.2	11	2.3	/	KF25
HD40	23.6	11.8	12.6	16.3	8.2	4.2	11	2.3	/	KF25
HD80	35.4	18.3	21.6	25.2	9.7	7	13	3.5	14.8	KF40
HD100	35.4	18.3	21.6	25.2	9.7	7	13	3.5	14.8	KF40