

CONFIDENTIAL

Yameliz Nava

7/2/2024

TRADE SECRET -CONFIDENTIAL AND PROPRIETARY
 EXCLUSIVELY OWNED BY KELLOGG-AMERICAN, 3620 W 11TH ST. HOUSTON, TX 77008. ANY COPYING, USE OR DISCLOSURE WITHOUT THE WRITTEN PERMISSION OF OMNI USA, INC. IS STRICTLY PROHIBITED. THIS MATERIAL IS PROTECTED UNDER TRADE SECRET AND UNFAIR COMPETITION LAWS. THE EXPRESSION OF THE INFORMATION IS PROTECTED UNDER FEDERAL COPYRIGHT LAWS. VIOLATIONS MAY RESULT IN CIVIL AND CRIMINAL FINES AND PENALTIES.

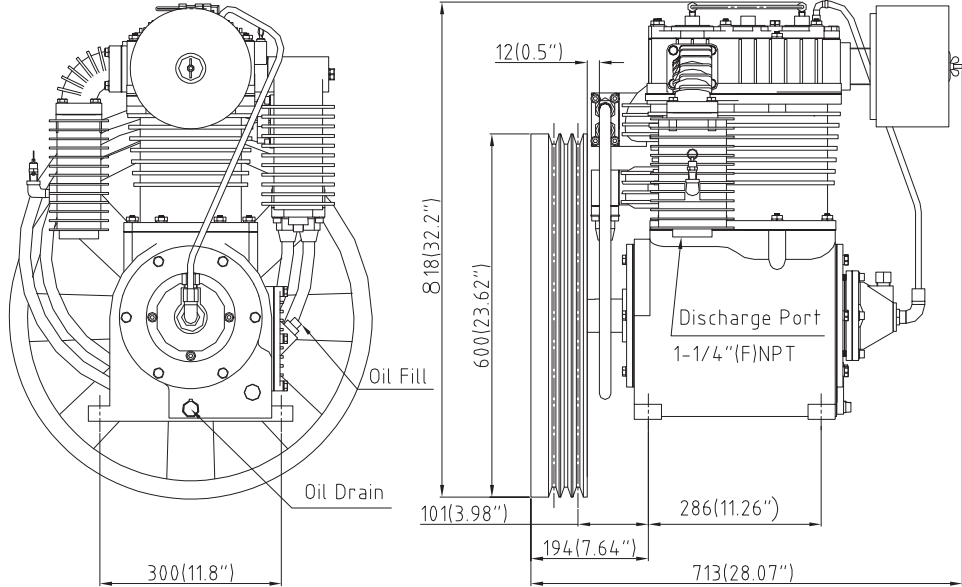
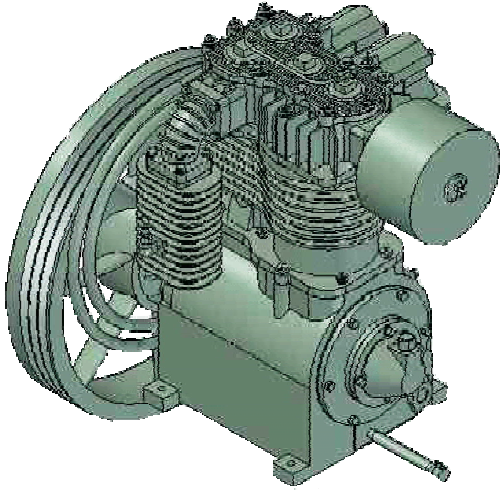

Specification:

- Power Range: 10~15HP/8~12.2Kw
- Maximum Pressure: 175Psi/12Bar
- Cylinders: 2
- Bore of LP: 6.10"/155mm
- Bore of HP: 3.35"/85mm
- Stroke: 4.57"/116mm
- RPM: 400~900
- Flywheel Dia./Groove: 24"/600mm/3B

Features:

- Cast Iron Crankcase
- Cast Iron Cylinder
- Cast Iron Cylinder Head
- Ductile Iron Crankshaft
- Ductile Iron Conn.Rod
- Centrifugal Unloader & Head Unloader
- Head Unloader Optional
- Bronze Bushing Wrist Pin
- Babbitt Bearings Crankshaft
- Ball Main Bearings
- Steel Breather and Brass Sight Glass
- Fill With DAB150 Lubricant Oil
- Power Coated Steel Filter Silencer
- Synthetic Lubricant as Option

Standard Package:

- Single: 1Pcs, Weight: 506LB/230Kg
- Crate: 4Pcs, Weight: 2116LB/960kg
- 20' Container: 56Pcs
- 40' Container: 80Pcs

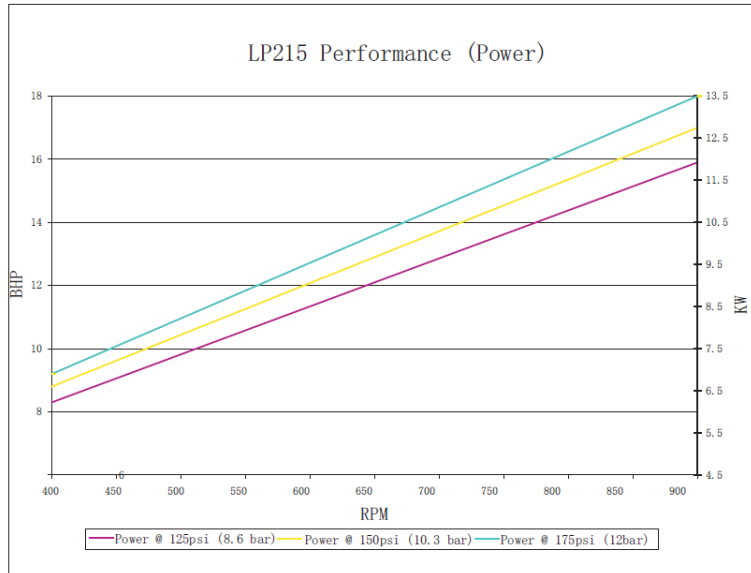
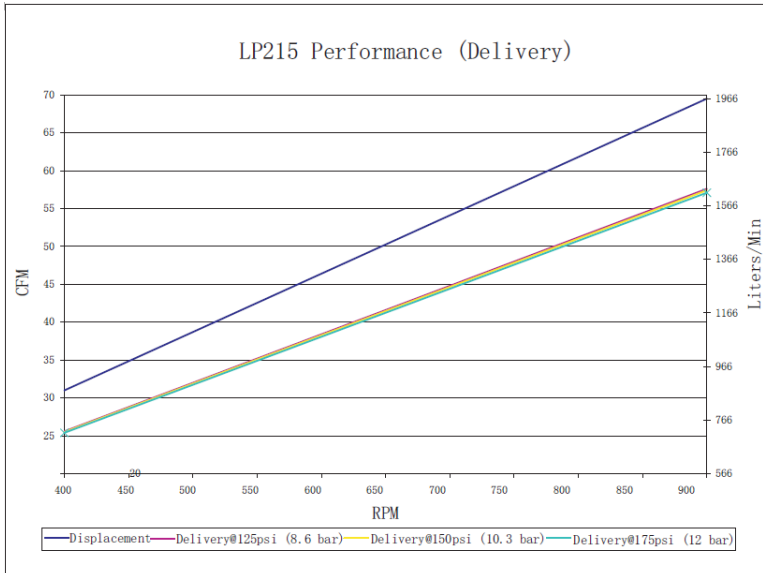

Kellogg
 COMPRESSOR
 Address: 3620 W 11th Houston, TX 77008
 Telephone: (719) 635-6291
 Email: po@ox-ind.com
 Website: kellogg-american.com

TITLE
 LP215 SPECIFICATIONS