



REFRIGERATED AIR DRYER
Non-Cycling High Pressure Dryer
Models HHPR1600-2400

Technical Manual



Save These Instructions

 **Hankison**TM

CONTENTS

CONTENTS	PAGE	CONTENTS	PAGE
1.0 INTRODUCTION	3	8.0 SCHEDULED MAINTENANCE	14
2.0 WARRANTY	3	8.1 INTRODUCTION.....	14
3.0 REFRIGERATED DRYER NOMENCLATURE ..	4	8.2 REFRIGERANT CONDENSER.....	14
4.0 RECEIVING AND INSPECTION	4	8.3 CONDENSATE DISCHARGE SYSTEM.....	14
4.1 INSPECTION.....	4	9.0 TECHNICIAN MODE	15
4.2 UNPACKING AND HANDLING.....	4	9.1 ENTERING TECHNICIAN MODE	16
5.0 SAFETY AND OPERATION PRECAUTIONS ..	5	9.2 ALARM LIST	17
6.0 PRINCIPLES OF OPERATION	7	10.0 TROUBLESHOOTING	18
6.1 INTRODUCTION.....	7	10.1 INTRODUCTION.....	18
6.2 AIR SYSTEM	7	10.2 PROBLEM / ACTION GUIDE.....	18
6.3 MOISTURE REMOVAL SYSTEM	8	11.0 GENERAL ARRANGEMENT DRAWING ..	20
6.4 REFRIGERATION SYSTEM	8	12.0 WIRING DIAGRAM	21
6.5.1 BASIC USER INTERFACE.....	9	13.0 REPLACEMENT PARTS	22
6.5.2 DISPLAY PARAMETERS.....	10	14.0 ENGINEERING SPECIFICATIONS	23
6.5.3 ACCESSING PARAMETERS.....	10	15.0 CORRECTION FACTORS	24
6.5.4 ALARMS AND THEIR FUNCTIONS	10		
6.5.5 START MODES	11		
7.0 INSTALLATION AND INITIAL START-UP ..	12		
7.1 LOCATION AND MOUNTING.....	12		
7.2 PIPING AND VALVES.....	12		
7.3 FILTRATION	12		
7.4 ELECTRICAL CONNECTION	12		
7.4.1 START MODE CONFIGURATION	12		
7.5 INITIAL START-UP	13		
7.5.1 START- UP SEQUENCE	13		

1.0 INTRODUCTION

Hankison's HHPR Non-Cycling refrigerated air dryer removes moisture, oil vapor, and other contaminants from compressed air. These contaminants are detrimental to pneumatically operated equipment, controls, instruments, machinery and tools. This removal is accomplished by cooling the air with a refrigeration unit to a temperature at which moisture in the air is condensed and separated from the air stream. The temperature the air is cooled to, normally between 36° and 40°F (2° and 4°C), is known as dew point. This dryer can be easily installed into various pneumatic systems in which dry air is required or desired. Please refer to Principles of Operation for complete operating details.

2.0 WARRANTY

The manufacturer warrants the product it manufactures, when properly installed, operated, applied, and maintained in accordance with procedures and recommendations outlined in manufacturer's instruction manuals, will be free from defects in material or workmanship for a period as specified below, provided such defect is discovered and brought to the manufacturer's attention within the aforesaid warranty period.

The manufacturer will repair or replace any product or part determined to be defective by the manufacturer within the warranty period, provided such defect occurred in normal service and not as a result of misuse, abuse, neglect or accident. Normal maintenance items requiring routine replacement are not warranted. The warranty covers parts and labor for the warranty period unless otherwise specified. Repair or replacement shall be made at the factory or the installation site, at the sole discretion of the manufacturer. Although not required for warranty consideration, it is recommended that the manufacture be contacted prior to doing any warranty related service work. This action will provide guidance and instruction on the repair often times authorization to perform the work. NOTE: The manufacture reserves the right to repair, replace in the case of warranty approval or reject the warranty claim once submitted.

Unauthorized service and use of unauthorized or pirated parts voids the warranty and any resulting charges or subsequent claim will not be paid. Products repaired or replaced under warranty shall be warranted for the unexpired portion of the warranty applying to the original product.

The foregoing is the exclusive remedy of any buyer of the manufacturer's product. The maximum damages liability of the manufacturer is the original purchase price of the product or part.

THE FOREGOING WARRANTY IS EXCLUSIVE AND IN LIEU OF ALL OTHER WARRANTIES, WHETHER WRITTEN, ORAL, OR STATUTORY, AND IS EXPRESSLY IN LIEU OF THE IMPLIED WARRANTY OF MERCHANTABILITY AND THE IMPLIED WARRANTY OF FITNESS FOR A PARTICULAR PURPOSE. THE MANUFACTURER SHALL NOT BE LIABLE FOR LOSS OR DAMAGE BY REASON OF STRICT LIABILITY IN TORT OR ITS NEGLIGENCE IN WHATEVER MANNER INCLUDING DESIGN, MANUFACTURE OR INSPECTION OF THE EQUIPMENT OR ITS FAILURE TO DISCOVER, REPORT, REPAIR, OR MODIFY LATENT DEFECTS INHERENT THEREIN. THE MANUFACTURER, HIS REPRESENTATIVE OR DISTRIBUTOR SHALL NOT BE LIABLE FOR LOSS OF USE OF THE PRODUCT OR OTHER INCIDENTAL OR CONSEQUENTIAL COSTS, EXPENSES, OR DAMAGES INCURRED BY THE BUYER, WHETHER ARISING FROM BREACH OF WARRANTY, NEGLIGENCE OR STRICT LIABILITY IN TORT.

Please note that the manufacturer's warranty for this product is intended to cover manufacturing defects and therefore does not cover consumable components (desiccants, filter elements, soft goods, standard maintenance kit wear items, etc.) or components that require periodic user adjustment (expansion valve, hot gas bypass valve or cooling water regulating valve) or calibration (dew point elements/sensors, gauge calibration, etc.)

Warranty Period

Parts and labor for two (2) years from the date of shipment from the factory.

AUTHORIZATION FROM THE SERVICE DEPARTMENT IS NECESSARY BEFORE MATERIAL IS RETURNED TO THE FACTORY OR IN-WARRANTY REPAIRS ARE MADE.

SERVICE DEPARTMENT: (724) 746-1100

3.0 REFRIGERATED DRYER NOMENCLATURE

Design Type	Size, Nominal Flow at 680 PSI	Condenser Type	Power	Options
HHPR = Hankison High Pressure Non Cycling	1600 2000 2400	A=Air Cooled W=Water Cooled	4=460-3-60	0 = Standard

4.0 RECEIVING AND INSPECTION

4.1 INSPECTION

Upon receiving your Hankison air dryer, please inspect the unit closely. If rough handling has been detected, please note it on your delivery receipt, especially if the dryer will not be uncrated immediately. Obtaining the delivery person's signed agreement to any noted damages will facilitate any insurance claims.

4.2 UNPACKING AND HANDLING

To facilitate handling during shipment, all dryer packages have been mounted on a base that provides for forklifting between two base channels. Forks should extend all the way through forklift channels to reduce unnecessary forces to the dryer during moving. Slings can be used to lift the crates, but spreader bars must be used to prevent the slings from exerting a force against the sides of the crates or the dryer.

WARNING

Under no circumstances should any person attempt to lift heavy objects without proper lifting equipment (i.e. crane, hoist, slings or fork truck). Lifting any unit without proper lifting equipment may cause serious injury.

5.0 SAFETY AND OPERATION PRECAUTIONS

Because an air dryer is pressurized and contains rotating parts, the same precautions should be observed as with any piece of machinery of this type where carelessness in operation or maintenance could be hazardous to personnel. In addition to obvious safety rules that should be followed with this type of machinery, safety precautions as listed below must be observed:

1. Only qualified personnel shall be permitted to adjust, perform maintenance or repair this air dryer.
2. Read all instructions completely before operating unit.
3. Pull main electrical disconnect switch and disconnect any separate controls lines, if used, before attempting to work or perform maintenance on the unit.
4. Do not attempt to service any part while machine is in an operational mode.
5. Do not attempt to remove any parts without first relieving the entire air system of pressure.
6. Do not attempt to remove any part of the refrigeration system without removing and containing refrigerant in accordance with EPA and local regulations.
7. Do not operate the dryer at pressures in excess of its rating.
8. Do not operate the dryer without guards, shields and screen in place.
9. Inspect unit daily to observe and correct any unsafe operating conditions.

OSHA Heading Descriptions

WARNING

“Warning” is used to indicate a hazardous situation which has some probability of death or severe injury. Warning should not be considered for property damage accidents unless personal injury risk is present.

CAUTION

“Caution” is used to indicate a hazardous situation which may result in minor or moderate injury.

NOTICE

“Notice” is used to indicate a statement of company policy as the message relates directly or indirectly to the safety of personnel or protection of property. Notice should not be associated directly with a hazard or hazardous situation and must not be used in place of “Danger,” “Warning,” or “Caution”.

NOTICE

The user of any air dryer manufactured by Hankison is hereby warned that failure to follow the above Safety and Operation Precautions may result in personal injuries or equipment damage. However, Hankison does not state as fact, nor does it mean to imply, that the preceding list of Safety and Operating Precautions is all inclusive, and further, that the observance of this list will prevent all personal injury or equipment damage.

DANGER



Air Under Pressure Will Cause Injury, Death Or Property Damage.

- Do Not Exceed Pressure Rating.
 - Relieve Press. Before Servicing.
 - Do Not Modify/Repair/Rework ASME Coded Pressure Vessels As Insurance Rating Affected.
- ! READ INSTRUCTION MANUAL !**

DANGER



HIGH VOLTAGE Can Cause Severe Injury Or Death.

- Some circuits may be energized when switch is off.
 - Disconnect and lockout ALL power sources before servicing.
- ! READ INSTRUCTION MANUAL !**

DANGER



Air Under Pressure Will Cause Injury, Death Or Property Damage.

- Relieve Press. Before Servicing.
 - Condensate Drain Discharges Under Pressure.
 - Drain Requires Periodic Cleaning (Service).
- ! READ INSTRUCTION MANUAL !**

5.0 SAFETY AND OPERATION PRECAUTIONS

ELECTRICAL CONNECTION BOX

- All Customer Connections To Be Made At This Location.
- See Attached Terminal Connection Diagram.
- Be Certain To Follow All NEC, State, Local and Other Applicable Codes During Installation.

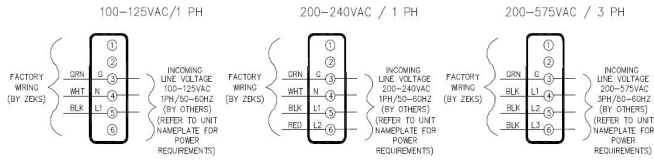

DANGER

ELECTRICAL CONNECTION BOX

CONTAINS HIGH VOLTAGE

- Turn Off Power And Lock Out At ALL Sources Before Opening To Perform Service.
- Remote Alarm Contact Wiring Has Control Power From Separate Source.

! READ INSTRUCTION MANUAL !



WARNING

Removing fuses will not disconnect power from dryer. Always disconnect power from ALL sources before performing service.

! READ INSTRUCTION MANUAL !

6.0 PRINCIPLES OF OPERATION

6.1 INTRODUCTION

Hankison HHPR dryers remove moisture from compressed air by cooling the air temperature to 36°F (2.2°C). This causes vapors to condense into liquid droplets which can then be easily removed from the air. The major systems of the dryer which contribute to its operation are the following: Air System, Moisture Removal System, Refrigeration System and the Controls System. The following paragraphs describe each of the systems in greater detail.

6.2 AIR SYSTEM

The Air System consists of the dryer components which are in contact with the compressed air. Referring to Figure 1 and following the bold "AIR FLOW," hot saturated air from the compressor enters the precooler/reheater where the air temperature is reduced prior to entering the chiller by the cool air exiting the air/moisture separator. This precooling allows for the use of a smaller refrigeration system. The air then goes into the chiller section where it is further cooled to the desired dew point by a thermal mass fluid. The temperature of the thermal mass fluid is maintained by the refrigeration circuit and controls. The air continues to the separator where moisture is removed, thereby, allowing the cool, dry air to return to the precooler/reheater to be heated by the incoming moist hot air. The air exiting the "reheater" portion of the dryer should be approximately 15°- 20°F lower than the inlet air temperature based on standard conditions at full rated flow.

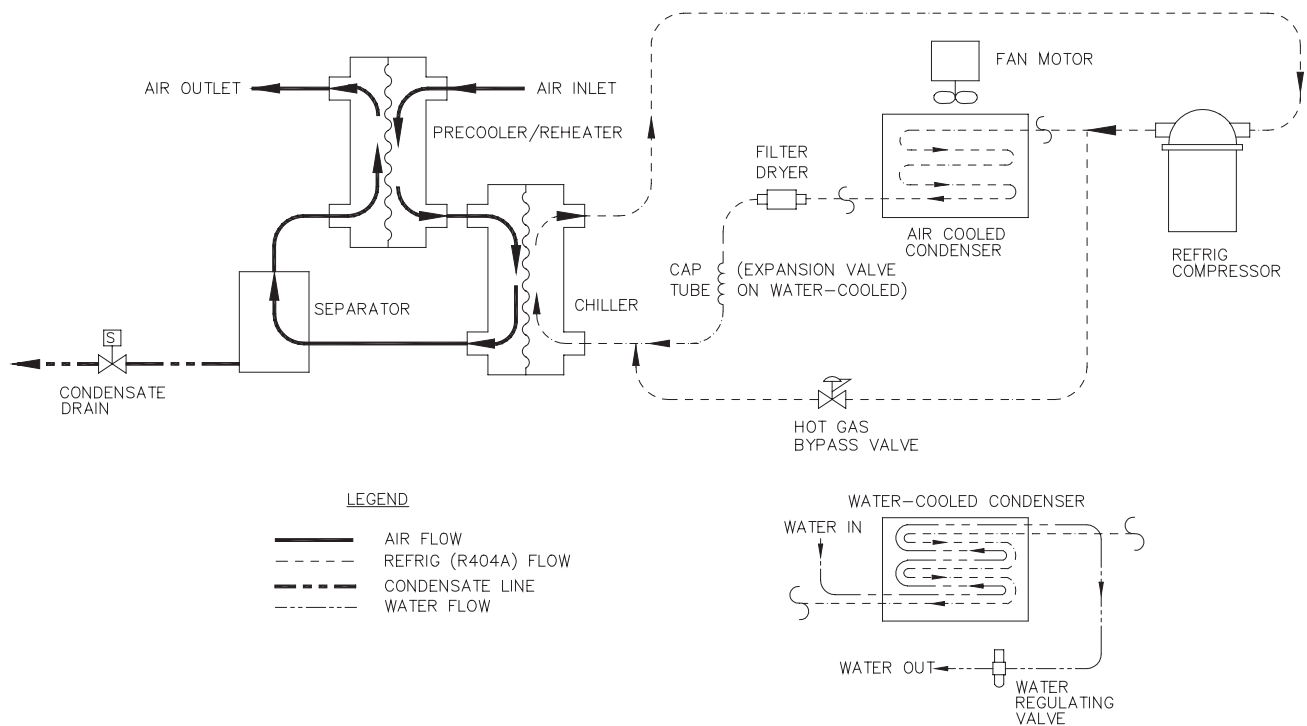

Figure 1 - Flow Diagram

6.0 PRINCIPLES OF OPERATION

6.3 MOISTURE REMOVAL SYSTEM

Liquid droplets are removed from the air stream in the separator. As the air and liquid mixture passes through the separator it spins, slows down and then changes direction. This causes the condensate to fall out of the air stream and collect in the bottom of the separator. The collected liquid is removed from the separator by a customer-provided condensate drain.

6.4 REFRIGERATION SYSTEM

The Refrigeration System consists of all the components which handle refrigerant R404A. This is a hermetically sealed closed-loop system. Referring to Figure 1 and following the dot-dash line, refrigerant is shown leaving the chiller evaporator section, which in the process of removing heat is changed from a low pressure liquid to a low pressure gas. This gas enters the suction side of the compressor where it is compressed into a high pressure gas. The high pressure gas is cooled in the air or water cooled condenser section becoming a high pressure liquid. It then goes through a permanent filter-dryer that ensures the refrigerant system is free of contaminants. A thermostatic expansion valve meters the refrigerant into the chiller's evaporator. The pressure is reduced upon entering the chiller evaporator where it removes heat from the air system. When there are low loads (low air flow rate or inlet temperature), a hot gas valve by-passes the condenser and throttling device (capillary tube). This valve maintains a minimum evaporator pressure, which corresponds to a chiller temperature of 34°F, thus preventing freeze-up.

6.5 CONTROLS

Hankison HHPR350-600 Refrigerated Compressed Air Dryers are equipped with the Digital Performance Controller (DPC).

For NonCycling dryers, the DPC displays the temperature of the air at the coldest point in the air stream, providing an indication of the outlet pressure dew point of the dryer. In addition, the DPC permits monitoring of dryer parameters and enunciation of alarm conditions.

The list below summarize the features the DPC:

- 1 X 16 Character Backlit LCD Display - Easy-to-read display provides continuous indication of dryer default parameter. Standard backlight permits viewing of critical information in low light environments.
- Electronic Drain with On/Off Time Adjustment: Included with DPC-equipped dryers is a solenoid drain valve. Control of the open and close time of the valve is set via the DPC Controller.
- Remote Start / Stop: DPC-equipped dryers offer a unique remote start / stop feature. This feature allows the dryer to be operated via a remote user-supplied

switch.

- Remote Alarm Contact: DPC-equipped dryers include a remote alarm contact to provide indication of any of the dryers alarms described later in this manual. Contact rated for 2A / 120V max.

The DPC Controller features three levels of access. The default level CUSTOMER MODE permits adjustment of dryer parameters to address seasonal variations for drain timing. A protected TECHNICIAN MODE permits access to and manipulation of additional parameters to address the initial machine set up. A password protected FACTORY MODE is also included for use by Hankison Service Personnel for troubleshooting the dryer.

All Hankison Non-Cycling dryers include a Hot Gas By-Pass (HGBP) Valve to maintain suction pressure and temperature. This valve is necessary during low load applications to prevent freeze-up in the chiller section. The normal suction pressure for no load conditions should never drop below 72 psig. *This setting may need adjustment to match the load/ambient conditions encountered.

***This adjustment is not a procedure covered under warranty as it is typically required for application specific conditions.**

For HGBP Valve adjustment note the following:

- Turning the adjustment screw clockwise raises suction pressure and exchanger temperature.
- Turning the adjustment screw counterclockwise reduces suction pressure and exchanger temperature.
- All adjustments should be made without air flow (load) on the dryer.

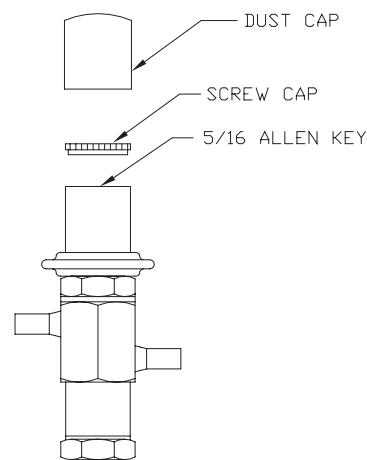

Figure 2 - HGBP Valve

6.0 PRINCIPLES OF OPERATION

CAUTION

Do not rotate Hot Gas By-Pass valve adjustment nut fully clockwise. Full clockwise rotation may result in refrigerant compressor damage. Any suction pressure setting above 90 psig is not recommended.

Hankison air cooled models utilize a microprocessor-controlled fan contactor to control the condensing temperature. This contactor controls the condensing temperature by cycling the fan based on refrigerant discharge pressure. When the unit reaches 275 psig, the microprocessor energizes the fan contactor that will run the fan until the discharge pressure is reduced to 195 psig. Should the discharge pressure continue to rise, a secondary fan will energize at 335 psig and continue to operate until the discharge pressure has been reduced to 235 psig.

For water cooled models, a high pressure cut out switch is positioned near the water regulating valve.

The DPC controller includes a digital readout for monitoring the discharge pressure of the refrigerant gas exiting the compressor. This reading will vary depending upon condenser type as indicated below:

- Air Cooled condensers with ambient temperatures between 80°F and 100°F, the refrigerant discharge gauge should read between 275 - 350 psig.
- Water cooled condensers utilize a water regulating valve. The water regulating valve comes pre-adjusted from the factory at 260 psig discharge pressure.

To compensate for water temperature variation, it may be necessary to adjust the water regulating valve to maintain a 260 psig discharge pressure. Adjustment can be done by rotating the adjusting screw counterclockwise for an increase in discharge pressure. For conditions where low water temperature and/or high water pressure are expected it is advisable to install a water pressure regulator ahead of the condenser.

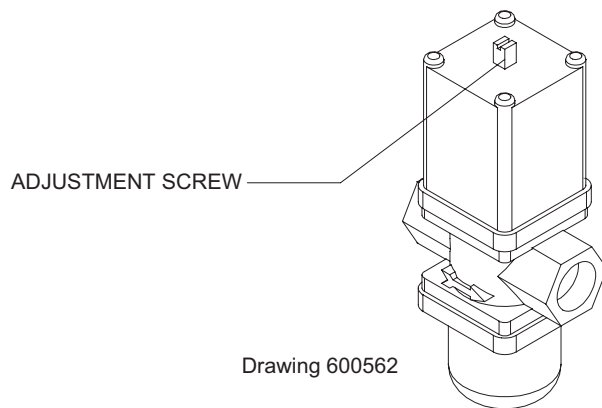

Figure 3 - Water Regulating Valve

6.5.1 BASIC USER INTERFACE

The DPC display provides the user with the operating parameters and their corresponding values. When power is supplied to the dryer, the DPC will illuminate and default to the "Standby" mode, displaying the "Press ON" prompt.

The following illustration summarizes the keypad functions.

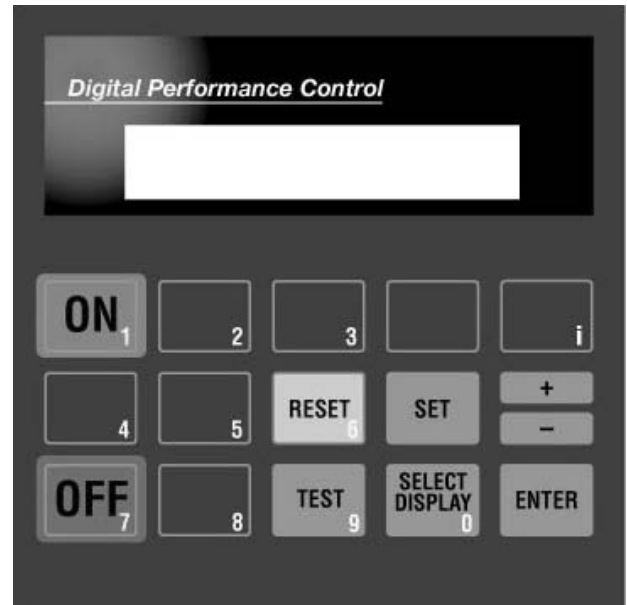

Figure 4 - User Interface

BUTTONS:

- **ON**
Places the dryer "On Line"; Initiates drain timer; Energizes refrigeration system.
- **OFF**
Places the dryer "Off Line"; Stops all automatic functions.
- **SELECT DISPLAY**
Allows the user to cycle through the available displays. The last display selected will remain displayed as the default display.
- **+ / -**
Allows user to increase set point values. Set point values cycle through a fixed range. Also allows entering negative numbers in FACTORY MODE.
- **TEST**
Allows user to manually activate the drain solenoid valve.
- **RESET**
Pressing once clears the local alarm indication and deenergizes the remote alarm contact. Should the alarm condition persist, the alarm will return after the alarm inhibit time has expired.

6.0 PRINCIPLES OF OPERATION

- **SET**
Permits the adjustment of parameters in TECHNICIAN and FACTORY MODE. In CUSTOMER MODE, allows user to scroll back through displays.
- **ENTER**
Used to accept changed parameters and set point values.
- **i**
Restricted Level access for factory use only. Not used for basic dryer functions. Not to be used by customer or service technician.

6.5.2 DISPLAY PARAMETERS

The DPC Controller is capable of displaying a number of system parameters. The following summarizes the parameters that can be accessed by the user from the DPC Controller depending on the DPC version:

- Chiller Temperature (CHLLR TEMP): The Chiller Temperature is the temperature, in degrees Fahrenheit, of the compressed air after the separator.
- Compressor Status (CMPRSSR): Displays whether the refrigeration compressor is "ON" or "OFF".
- Discharge Pressure (P disch): Displays the discharge pressure of the refrigeration system.
- Suction Temperature (T suction): Displays the suction temperature, in deg. F, of the refrigeration system. This value is useful in determining superheat of the refrigerant.
- Suction Pressure (P suction): Displays the suction pressure, in psig, of the refrigeration system.
- Drain Interval (DRN INT): Displays the length of time, in minutes, between operation of the solenoid drain.
- Drain On (DRN ON): Displays the length of time, in seconds, that the solenoid drain is open.
- Cumulative Dryer Hours (CUM DRYER HR): Displays the length of time, in hours, that the dryer has been operational.

Depressing the SELECT DISPLAY button repeatedly scrolls through the above non-adjustable displays. The Customer Set Points appear at the end of the list and may be adjusted by the end user to match seasonal refrigeration and drain operation. These settings are as follows:

- Drain Interval (DRN INT)
- Drain On (DRN ON)

6.5.3 ACCESSING PARAMETERS

Accessing each of the parameters in the CUSTOMER MODE is accomplished by depressing the SELECT DISPLAY button.

6.5.4 ALARMS AND THEIR FUNCTIONS

There are several alarms detected by the DPC to alert the user of an out of tolerance condition. Once each alarm is detected, a description of the alarm will appear in the screen and the remote alarm contact will close. Note that during the alarm condition, the SELECT DISPLAY button may be depressed to scroll through the available parameters. After approximately 30 seconds, the alarm screen will reappear, provided the alarm condition persists.

Alarm	Display	Alarm Set Point
HIGH PRESSURE CUTOUT	HI PRESS CO	See Table 1
HIGH TEMPERATURE ALARM	HITEMP ALRM	55 °F
LOW TEMPERATURE ALARM	LOTEMP ALRM	30 °F

The alarm names and a brief description of each are described in detail below. Note that some alarms will enunciate only after a prescribed alarm delay. Refer to the TECHNICIAN MODE section of this manual for factory default alarm delay periods.

HIGH TEMPERATURE ALARM (HITEMP ALARM):

When the air temperature at the inlet to the separator reaches the factory alarm set point, after an alarm delay, the alarm will be activated. This alarm condition that may not necessarily damage the dryer when subjected to long-term exposure. It may, however, have a significant impact on downstream processes and thus should be investigated upon detection. Note that this alarm will not shut down the dryer. This alarm will reset automatically once the alarm condition is rectified.

LOW TEMPERATURE SAFETY ALARM (LOWTEMP ALARM):

If the dryer chiller temperature falls below the factory set point and remains below this set point for the alarm delay time, the alarm routine will activate. This alarm condition may cause damage to the dryer when subjected to continuous or longterm exposure. Note that this alarm will shut down the dryer after a response time delay. This alarm will reset automatically once the alarm condition is rectified.

HIGH PRESSURE CUTOUT ALARM (HI PRESS CO):

If the discharge pressure of the refrigerant is determined to be above the set point, the alarm routine will activate. This alarm condition may cause damage to the dryer when subjected to continuous or long-term exposure. Note that this alarm will shut down the dryer after a response time delay. The operator must depress the RESET button in order to clear the alarm and restart the refrigeration system.

6.0 PRINCIPLES OF OPERATION

HIGH DRAIN LEVEL ALARM - OPTIONAL (DRAIN LVL ALARM): On dryers equipped with the optional High Drain Level Alarm, should condensate rise to a predetermined level in the separator, a liquid level switch will signal the DPC and the High Drain Level Alarm will enunciate. In addition to indicating the alarm on the LCD and closing the remote alarm contact, the High Drain Level Alarm will open the solenoid drain in an attempt to correct the problem. The condition must be addressed to reset the dryer.

Parameter	R-22	R-404A	R-407C
FAN 1 ON	235 psig	275 psig	235 psig
FAN 1 OFF	195 psig	195 psig	195 psig
FAN 2 ON	265 psig	335 psig	265 psig
FAN 2 OFF	210 psig	235 psig	210 psig
HPCO (Air Cooled)	400 psig	450 psig	400 psig
HPCO (Water Cooled)	320 psig	320 psig	320 psig

Table 1

6.5.5 START MODES

Hankison dryers are capable of starting in one of three start modes. Note that to protect the refrigeration compressor from repeated rapid starts, the DPC is equipped with an anti-short cycle (ASC) delay. The ASC delay will countdown from the factory set point (see TECHNICIAN MODE). Only after the ASC delay has timed out will the refrigeration system operate. Below are brief descriptions of these various start modes.

Manual Mode

Hankison dryers are shipped from the factory in the Manual Mode. After power is supplied to the dryer, the user will be presented with the ASC delay, followed by the "PRESS ON BUTTON" display. After the ASC delay has timed out, the dryer will only start once the ON button is depressed. In this configuration, to restart the dryer, the user must manually depress the ON button on the dryer's control panel.

Auto Restart Mode

After power is applied to the dryer, and once an anti-short cycle delay has timed out, the dryer will start automatically. In addition, this mode of operation allows manual control of the dryer via the ON & OFF pushbuttons. This is useful for applications where automatic restarting of the dryer is desired after a power failure has occurred.

Remote Automatic Mode

This mode of operation allows the user to control the dryer remotely and requires the installation of a customer-supplied contact. With power applied to the dryer and once the anti-short cycle delay has timed out, the dryer will start automatically once the switch is closed. In addition, this mode of operation allows manual control of the dryer via the ON & OFF pushbuttons.

7.0 INSTALLATION AND INITIAL START-UP

7.1 LOCATION AND MOUNTING

The dryer should not be located in an area where ambient temperature is likely to exceed 113°F (45°C) or be less than 50°F (10°C). The dryer must be located in an area that provides sufficient clearance from walls and other adjoining equipment to allow easy access for servicing and maintenance requirements. A minimum of 30 inches is required to allow free flow of air to the condenser inlet.

On installations with a relatively steady flow rate, the dryer is normally connected after the air receiver. If loads fluctuate widely, the dryer should be positioned ahead of the receiver and sufficient storage capacity downstream is necessary to prevent excessive air flow through the dryer.

NOTICE

When installed after any compressor that causes significant vibration or air pulsation, such as reciprocating compressors, proper vibration isolation and pulsation dampening devices should be added to protect the dryer.

NOTICE

Failure to comply to the above instructions may result in equipment malfunction and will void warranty.

NOTICE

Always use a backup wrench when making any threaded connection to the dryer. Failure to use a backup wrench may result in damaged tubing and components internal to the cabinet.

7.2 PIPING AND VALVES

Install piping, fittings and accessories as required for specific site conditions and requirements. For proper dryer operation, customer shall supply a suitable drain to be installed at the condensate discharge of the dryer's air-moisture separator.

7.3 FILTRATION

To protect the air dryer from gross contamination associated with compressor oil and debris and ensure maximum dryer performance, a prefilter is recommended. Prefilters and afterfilters sized to your drying application can be provided by Hankison. Call your local distributor to select the filter that best suits your filtration requirements. In addition to air filtration, condensate discharge oil/water separators are also available to address stringent EPA regulations.

7.4 ELECTRICAL CONNECTION

Equipment is available in various electrical configurations. All customer connections can be made at the terminal connections located in the customer electrical connection box on the rear of the dryer. (Refer to General Arrangement and appropriate Wiring Diagrams.)

A suitable fused disconnect switch or circuit breaker, in accordance with national and local code requirements, is recommended for all Hankison equipment. Refer to the Engineering Specifications Section for voltage requirements and load.

CAUTION

Never wire directly or connect any additional wires to the compressor junction box. This will cause severe system malfunction.

7.4.1 START MODE CONFIGURATION

Hankison dryers can be configured for three variations of start modes: Manual Mode, Automatic Mode and Remote Mode. The instructions below describe the methods to configure the dryer for a particular Start Mode.

- A. Manual Mode (Factory Default) - No modification required to operate dryer in Manual Mode. Once power is applied, dryer can be started or stopped by depressing the local ON / OFF pushbuttons located on the front panel.
- B. Auto Restart Mode - Auto Restart Mode permits the dryer to start after a brief delay once power is applied to the dryer. In TECHNICIAN MODE, changing the Auto Restart parameter from the default "N" to "Y" using the SET button enables this mode of operation. Note that the dryer's touch pad will still affect dryer operation. Depressing the OFF button will de-energize the refrigeration compressor and all other electrical components. After the OFF button has been depressed, the user must depress the ON button to permit the dryer to operate.
- C. Remote Mode - Remote Mode allows the dryer to be turned ON or OFF via a remote switch supplied by the customer. This mode will work regardless of the setting for Auto Restart. The dryer must be powered on for this feature to take effect. To enable this feature:
 - Install N.O. remote switch as indicated on the appropriate wiring diagram.
 - Customer-supplied contact should be rated at 1A at 24V. To operate dryer, close switch or contact and allow dryer to start after an initial delay. The local On / OFF pushbuttons may also be used at any time after contact closure.

7.0 INSTALLATION AND INITIAL START-UP

7.5 INITIAL START-UP

NOTICE

For water cooled models, the water valve must be manually opened to ensure that the condenser is full of water prior to start-up.

7.5.1 START- UP SEQUENCE

- Apply power to dryer. LCD Panel will illuminate. The Anti-Short Cycle delay will commence counting down.

NOTICE

After installation or a prolonged shutdown, start the dryer with no air load (no air flow). This enables the dryer to reach its proper operating temperature in the shortest time possible (typically within 5 minutes for HHPD dryers).

- Start Dryer, using one of the following methods, depending on Start Mode setting:
 - Manual Mode - Press the ON pushbutton.
 - Auto Restart Mode - No additional action required
 - Remote Automatic Mode - Close the remote contact.
- For NonCycle dryers, after the initial delay has timed out, the compressor is energized. The suction pressure gauge will typically pull down between 76 and 85 psig. The Hot Gas By-Pass Valve may require adjustment on start-up. Refer to section 6 for details.

After 5 minutes, slowly introduce air flow to the dryer.

After the alarm delay, provided the Chiller Temperature is greater than the HIGH TEMPERATURE ALARM set point, the dryer will go into HIGH TEMPERATURE ALARM. The LCD panel will indicate the alarm and the refrigeration system will continue to operate. Pressing the SELECT DISPLAY button will permit viewing of the available dryer parameters during this alarm condition. Note that the alarm condition screen will reappear after approximately 30 seconds until the alarm condition is cleared.

The CHILLER TEMPERATURE will gradually drop as indicated on the display. Once the temperature falls below the HIGH TEMPERATURE ALARM set point, the alarm will reset and the LCD panel will return to its default display.

Drain settings should be checked as described earlier in this manual and the drain manufacturer's instructions.

8.0 SCHEDULED MAINTENANCE

8.1 INTRODUCTION

Hankison NonCycle refrigerated air dryers require little maintenance. These dryers utilize hermetically sealed compressors which do not require any lubrication. Hankison recommends component inspection and service at regular intervals to obtain maximum performance from your dryer.

8.2 REFRIGERANT CONDENSER

For standard dryers, regular inspection and cleaning of the condenser is recommended. Hankison dryers may be equipped with an optional ambient air filter designed to protect the condenser from dirt and debris that can accumulate on the condenser. For proper operation with this option, it is imperative that this filter be inspected and cleaned on a regular basis. Annual replacement of the filter is recommended. For applications where excessive dirt, dust or debris is encountered, more frequent inspection and cleaning may be required.

8.3 CONDENSATE DISCHARGE SYSTEM

On a minimum of a monthly basis, the operation of the customer-supplied drain should be checked. The drain should be removed and cleaned in accordance with the manufacturer's instructions to ensure no debris from the system is trapped inside the drain.

WARNING

If dryer is installed without a drain isolation valves (filter stop), failure to depressurize the dryer may result in serious injury. Do not remove the drain valve without depressurizing the unit.

CAUTION

Failure to periodically check and clean drain valve may result in drain becoming clogged. Should this occur, moisture remaining within separator may travel downstream of dryer.

9.0 TECHNICIAN MODE

The DPC provides a protected TECHNICIAN MODE to manipulate several parameters not accessible by the typical operator. This mode also permits viewing of the factory settings to aid in troubleshooting of the dryer. Below is a list of parameters that can be accessed and manipulated by the technician in the TECHNICIAN MODE:

PARAMETER	DISPLAY	SET POINT
SOLENOID DRAIN ENABLE	DRAIN ENABLE	ON (or OFF)
CRANKCASE HEATER DELAY	CCH DLY	0 (or 2,4,8,12 hours)
AUTO RESTART ENABLE	AUTO RESTART	N (or Y)

In TECHNICIAN MODE, the following parameters can be viewed but not changed:

PARAMETER	DISPLAY	SET POINT
OPERATING MODE	OP MODE	HS or NC
REFRIGERANT	REFRIG	22 or 404 or 407
CONDENSER TYPE	COND	AC OR WC
OPERATING TEMPERATURE DIFFERENTIAL	T OP DIFF	4
SHORT CYCLE DELAY	SHT CYC DLY	3
HIGH PRESSURE CUTOUT	HPCO	See Table-1
HIGH PRESSURE CUTOUT DELAY	HPCO DLY	10
LOW PRESSURE CUTOUT	LPCO	See Table-1
LOW PRESSURE CUTOUT DELAY	LPCO DLY:(10)	10
HIGH TEMPERATURE ALARM	HITEMP ALRM	55
LOW TEMPERATURE ALARM	LOWTEMP ALRM	30
LOW TEMPERATURE ALARM DELAY	LOTEMP DLY	120
DISCHARGE PRESSURE TRANSDUCER	Pd TRANS	Y (N)
SUCTION PRESSURE TRANSDUCER	Ps TRANS	N (Y)
SUCTION TEMPERATURE PROBE	Ts Probe	N (Y)
FAN 1 ON PRESSURE	FAN1 ON	See Table-1
FAN 1 OFF PRESSURE	FAN1 OFF	See Table-1
FAN 2 ON PRESSURE	FAN2 ON	See Table-1
FAN 2 OFF PRESSURE	FAN2 OFF	See Table-1

9.0 TECHNICIAN MODE

9.1 ENTERING TECHNICIAN MODE

WARNING

TECHNICIAN MODE should only be entered by qualified service personnel. Altering the set points in TECHNICIAN MODE will have a significant effect on the operation of the dryer. Incorrect set points may damage dryer and cause potential serious injury.

To enter the TECHNICIAN MODE, perform the following keystrokes:

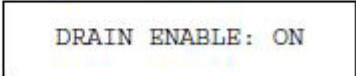

   Pressing the "2" and "3" buttons simultaneously enters the TECHNICIAN MODE.

  Depressing SELECT DISPLAY scrolls through the available parameters. The first three parameters viewed are adjustable in TECHNICIAN MODE.

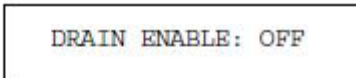
The DRAIN ENABLE parameter determines whether the DPC shall control an electronic solenoid drain valve. A value of "ON" will permit the DPC to control the drain valve. A value of "OFF" will disable this feature. This would be suitable for servicing the drain valve or if an independent no air loss drain is to be used with the dryer. To change the DRAIN ENABLE set point from the displayed set point, perform the following. Otherwise, depress the SELECT DISPLAY button to advance to the next adjustable parameter:

  For parameters with "ON / "OFF" or "Y" / "N" choices, the set point is changed using the SET button. Pressing the SET button changes the Drain Enable from ON to OFF.



  Depressing ENTER saves the selected set point.

  Depressing the SELECT DISPLAY button advances to the next adjustable parameter for the Crankcase Heater Delay. This parameter must not be altered unless instructed by Hankison Service personnel.

NOTICE

The Crankcase Heater Delay set point must not be altered unless directed by Hankison Service Personnel. Improperly altering the set point may result in damage to the dryer. Contact Hankison before altering the default set point.

The AUTO RESTART feature permits the dryer to operate once power is applied to the dryer without requiring operator intervention. This would be desirable should the user wish to have the dryer restart automatically after a power outage. To change the AUTO RESTART set point from "N" (NO) to "Y" (YES), perform the following. Otherwise, depress the SELECT DISPLAY button to advance to the next display:

  For parameters with "ON / "OFF" or "Y" / "N" choices, the set point is changed using the SET button. Pressing the SET button changes the Drain Enable from ON to OFF.

  Depressing ENTER saves the selected set point.

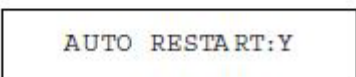
  Depressing the SELECT DISPLAY button advances to the next adjustable parameter for the Crankcase Heater Delay. This parameter must not be altered unless instructed by Hankison Service personnel.

9.0 TECHNICIAN MODE

WARNING

Changing the AUTO RESTART feature to "Y" will permit the dryer to operate automatically once power is applied and after a brief delay. Proper warning signs should be affixed to the dryer to alert users and service personnel that dryer may start without warning. Failure to do so may result in serious injury.



END TECH SET PTS

Depressing the SELECT DISPLAY button displays the END TECH SET PTS display.

The remaining non-adjustable parameters may be viewed by depressing the SELECT DISPLAY button as required to arrive at the desired display.

NOTICE

To exit the TECHNICIAN MODE at any time, depress the "BLANK" button located above the SET button to return to the CUSTOMER MODE.

9.2 ALARM LIST

At the end of the list of non-adjustable parameters, the DPC displays a list of the most recent 20 alarm conditions. This list can facilitate troubleshooting the dryer.



BEGIN ALARM LIST

At the end of the list of parameters, depressing the SELECT DISPLAY button displays the beginning of the ALARM LIST.



HPCO

Depressing the SELECT DISPLAY button displays the alarms that the dryer has experienced, with the most recent alarm displayed first. The actual display will depend on the most recent alarm detected by the DPC.



END ALARM LIST

The list of alarms can be scrolled by depressing the SELECT DISPLAY button as needed. At the end of the alarm list, the END ALARM LIST screen is displayed.



BEGIN ALARM LIST

Depressing the SELECT DISPLAY list displays the ALARM LIST screen at the top of the ALARM LIST.

The Alarm List will repeat as long as the SELECT DISPLAY button is depressed. To EXIT the ALARM LIST, perform the following:



TECH SET MODE

Depressing the BLANK button (located above the SET button) returns the controller to the top of the TECHNICIAN MODE.



CHLLR TEMP: 37

Depressing the BLANK button again returns the controller to the default display of the CUSTOMER MODE.

10.0 TROUBLESHOOTING

10.1 INTRODUCTION

Hankison dryers are designed for reliable, trouble-free operation. In the event of any dryer malfunction, the guide below has been developed to facilitate problem identification and corrective actions.

⚠ WARNING

An air dryer always operates under pressure. Any maintenance procedure that involves disassembly of pipe fittings, valves or any other components requires the dryer be isolated from the compressed air stream and fully depressurized.

⚠ WARNING

Prior to working on the unit, make sure that all circuit breakers or disconnected switches are tagged "Out of Service."

10.2 PROBLEM / ACTION GUIDE

PROBLEM	SYMPTOM(S)	POSSIBLE CAUSE	CORRECTIVE ACTION
Moisture down stream	Dryer is properly cooling air stream (Check Chiller. Temp on controller)	Drain failure or timer adjustment is required	Depress "TEST" button - if drain valve operates then adjust timing (See Section 6)
			Depress "TEST" button - if DRAIN TEST is displayed but valve does not open, ensure wiring connections are secure and power is being applied to the solenoid coil. If valve continues not to open, clean as described in Maintenance Section of this manual.
			Depress "TEST" button - if display does not indicate DRAIN TEST, contact distributor.
	Inlet and outlet temperatures are the same.	Excessive flow	Check inlet and outlet pressures and system design capacity.
		Dryer by-pass valve not closed	Correct cause of excessive flow. Close by-pass valve
		No power to the dryer	Check power supply and fuses/circuit breakers
		High suction pressure	Check and clean ambient air filter.
		Refrigerant leak	Check suction pressure gauge if reading is 0 psig, turn dryer off and contact your distributor
Moisture down stream	Inlet and outlet temperatures are the same.	Compressor and fan not running.	Check Chiller Temperature
			Check MAIN CONTROL fuse.

10.0 TROUBLESHOOTING

PROBLEM	SYMPTOM(S)	POSSIBLE CAUSE	CORRECTIVE ACTION
Moisture down stream	Inlet and outlet temperatures are the same.	Compressor and fan not running. Controller indicates compressor is ON.	Compressor relay may be bad, replace relay
			Check for loose wire connections at contactor or loss of power at control board
			Defective control board - replace as necessary
			Contact your local distributor for further assistance.
Apparent controller display malfunction	Display Blank	Blown Fuse	Check Fuses
		Board Failure	Contact your local distributor for further assistance.
	Unrealistic temperature displayed	Probe loose, off connection or defective probe	Inspect probe cable and terminal connection Replace probe
		Erratic or inaccurate temperature readings	Probe not completely in thermal well
	Defective probe		Replace probe
	Unrealistic pressure displayed	Transducer loose, off connection or defective transducer	Inspect transducer cable and terminal connection
Replace transducer			
High pressure drop across dryer	Outlet pressure substantially lower than inlet pressure System operating temperature is above 32°F	Inlet and outlet valves not completely open	Open valves
		Inlet and outlet filters blocked up	Change filter elements
	Outlet pressure substantially lower than inlet pressure System operating temperature is below 32°F	Compressor relay / contactor.	Replace relay / contactor.
		stuck	Replace relay
		DPC relay bad Probe not completely in thermal well	Inspect probe and check readings against independent source (eg. temperature analyzer/pyrometer/ice bath) both in exchanger well and to ambient
		Problem persists	Turn dryer off and consult your local distributor for further assistance

11.0 GENERAL ARRANGEMENT DRAWING

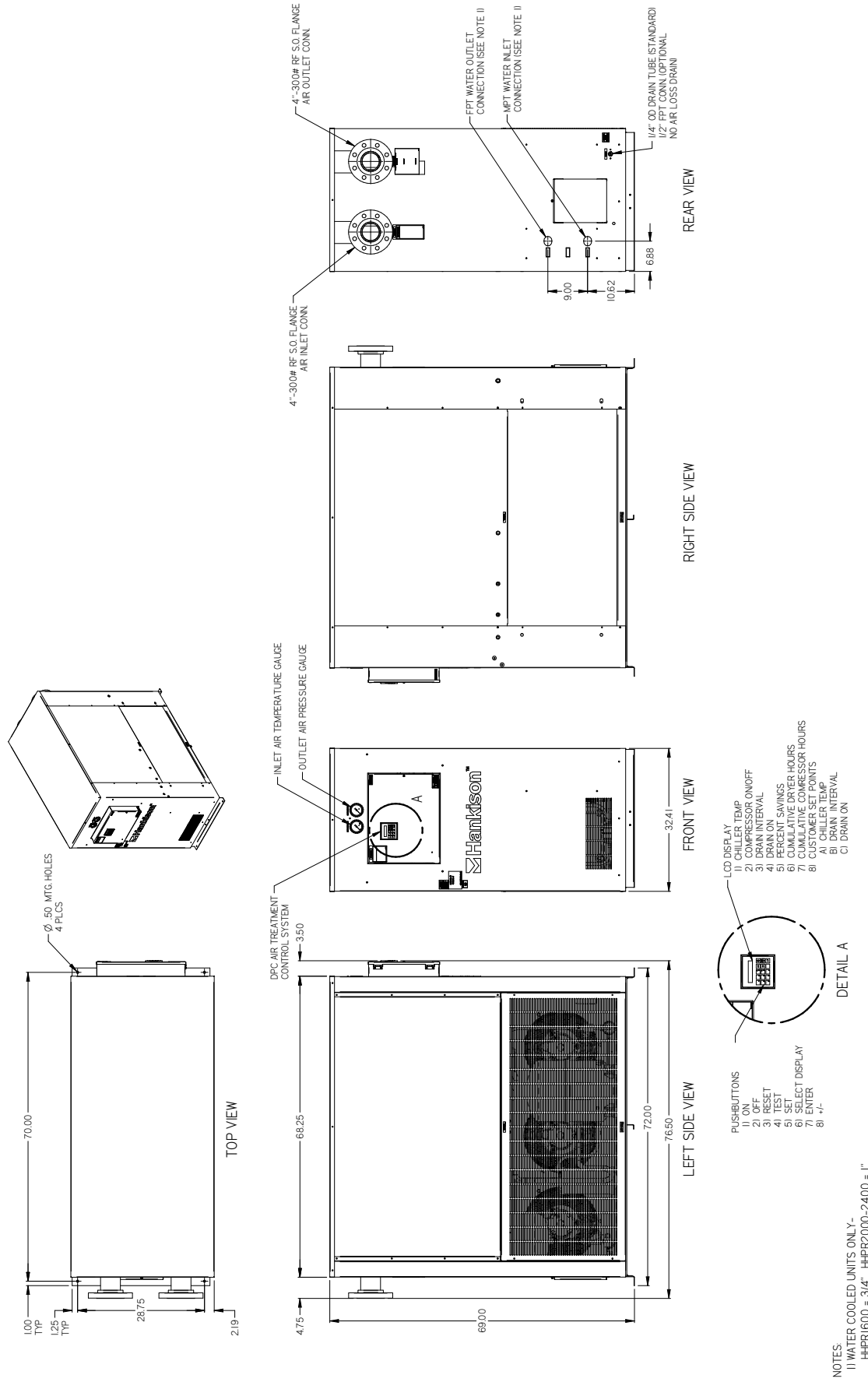

GENERAL ARRANGEMENT
HHPRI600 - 2400
47877992_A

NOTES
1) WATER COOLED UNITS ONLY -
HHPRI600 = 3/4", HHPRI2000-2400 = 1"

12.0 WIRING DIAGRAM

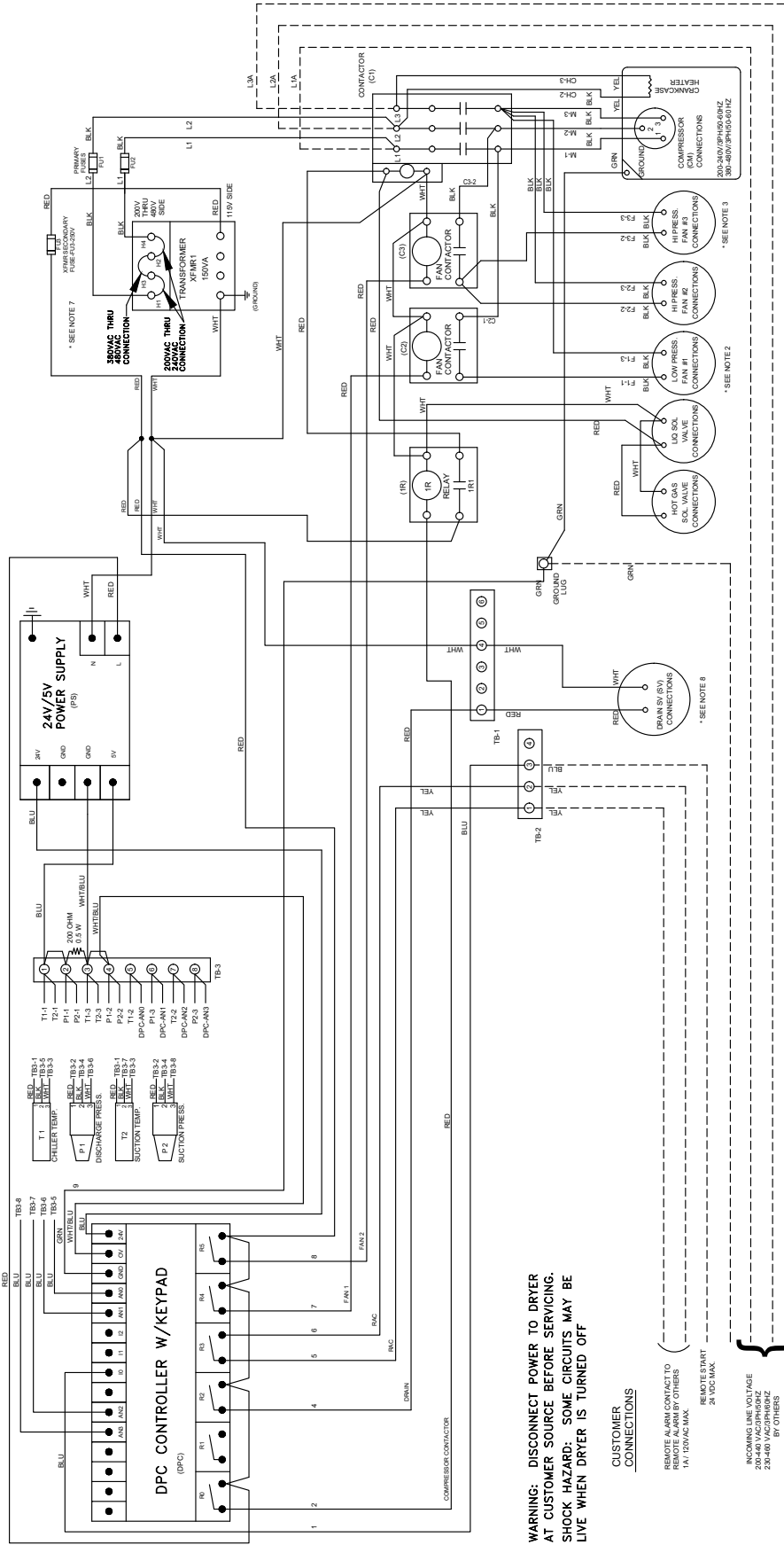

WARNING: DISCONNECT POWER TO DRYER AT CUSTOMER SOURCE BEFORE SERVICING. SHOCK HAZARD- SOME CIRCUITS MAY BE LIVE WHEN DRYER IS TURNED OFF

CUSTOMER CONNECTIONS

- REMOVES A UNIT CONNECTION TO REMOTE ALARM BY OTHERS 1A/ 120VAC MAX.
- REMOTE START 24 VDC MAX.
- INCOMING LINE VOLTAGE 200-440 VAC/50/60HZ 230-440 VAC/50/60HZ 50 OTHERS

- NOTES:**
1. CUSTOMER POWER HOOK UP IN THE ELECTRICAL POWER ENCLOSURE AT CONTACTOR
 2. FAN MOTOR #1 IS NOT INCLUDED ON WATER-COOLED UNITS
 3. FAN MOTOR #3 ON MODEL: HHPR2000 & HHPR2400 ONLY.
 4. CONNECTIONS TO BE LABELED IN ENCLOSURE TO MATCH WIRING DIAGRAM PER UL-508.
 5. CONTROL AT SUPPLY VOLTAGE - BLUE
 6. POWER WIRES TO BE LABELED PER THE DRAWING.
 7. JUMPERS AND CONNECTIONS MAY VARY DEPENDING ON INCOMING VOLTAGE.
 8. DRAIN VALVE NOT INCLUDED WITH NO AIR LOSS DRAIN.

WIRING DIAGRAM
HHPR1600-2400,
208-575/3/60, 200-440/3/50
47879565_A

13.0 REPLACEMENT PARTS

Description	HHPR1600A	HHPR2000A	HHPR2400A
ACCUMULATOR	24217465	23958911	23958911
BLADE, FAN	38456166	38456166	23390826
COMPRESSOR	38052312	23407836	23380660
CONDENSER, AIR-COOLED	23390800	23390800	47663902001
CONTACTOR, 1-POLE 600V	38052858	38052858	38052858
CONTACTOR, 3-POLE 600V	38054201	38054201	38054201
CONTROLLER, PROGRAMMABLE LOGIC	24331803	24331803	24331803
CRANKCASE HEATER	24244261	24244261	24201378
FAN GUARD KIT	38456174	38456174	38456174
FILTER DRYER	38052023	38052031	38052031
FUSE BLOCK, 2-POLE, 600V, 30A, 13/32"x1-1/2"	23717598	23717598	23717598
FUSE, 0.5A 600V	38054268	38054268	38054268
FUSE, 1.25A 250V	23273287	23273287	23273287
GAUGE, PRESSURE 2", 0-1000 PSI	24808271	24808271	24808271
GAUGE, TEMPERATURE 2"	23635600	23635600	23635600
GROUND LUG	23712195	23712195	23712195
MOTOR, FAN	38052734	38052734	23390834
POWER SUPPLY	38052379_683956	38052379_683956	38052379_683956
PROBE, TEMPERATURE, 8-FT LEAD	38052445	38052445	38052445
RELAY, DPDT	38052767	38052767	38052767
RESISTOR, 200 OHM	38054151	38054151	38054151
STRAINER, "Y" 1/4"	23358153	23358153	23358153
TERMINAL BLOCK, 4-POLE, 300V/20A	23717564	23717564	23717564
TERMINAL BLOCK, 6-POLE, 300V/20A	23717580	23717580	23717580
TERMINAL BLOCK, 30A, 600V AC/DC	24805111	24805111	24805111
TRANSDUCER CABLE, 10-FT LEAD	38052429	38052429	38052429
TRANSDUCER, 0-300 PSIA	38052395	38052395	38052395
TRANSDUCER, 0-500 PSIA	38052403	38052403	38052403
TRANSFORMER	38053252	38053252	38053252
VALVE, ACCESS, HIGH FLOW	47626953001	47626953001	47626953001
VALVE, ACCESS 9 WAY OD	23717622	23717622	23717622
VALVE, BALL 1/4", 2000 PSI	23358203	23358203	23358203
VALVE, EXPANSION	23273584	23273584	23273584
VALVE, HOT GAS BYPASS	23569718	23569718	24158438
VALVE, RELIEF	24663239	24663239	24663239
VALVE, DRAIN SOLENOID 1/4" 750PSI	23358146	23358146	23358146

14.0 ENGINEERING SPECIFICATIONS

MODEL		HHPR1600	HHPR2000	HHPR2400
Air Flow Rate at Nominal Conditions ¹	SCFM (m ³ /hr)	1600 (2718)	2000 (3398)	2400 (4078)
Pressure Dewpoint at Nominal Conditions ¹	°F (°C)	40 (4.4) ⁽³⁾	40(4.4) ⁽³⁾	40 (4.4) ⁽³⁾
Min. Max Ambient Temperature	°F (°C)	36..115 (2...46)		
Nominal Ambient Temperature ¹	°F (°C)	100 (37.7)		
Nominal Inlet Air Temperature ¹	°F (°C)	100 (37.7)		
Nominal Inlet Air Pressure ¹	psig (barg)	680 (46.9)		
Max Inlet Air Pressure	psig (barg)	680 (46.9)		
Air pressure drop	psid (bar)	2.4 (0.17)	3.1 (0.21)	3.3 (0.23)
Inlet & Outlet Connection	Type	Class 300 RF Flange		
Inlet & Outlet Connection	Size	4"	4"	4"
Refrigerant Type		R404A		
Refrigerant Quantity ²	lb (kg)	16 (7.26)	18 (8.16)	22 (9.98)
Heat Rejection	btu/hr (kW)	67920 (19.9)	99090 (29.0)	112000 (32.8)
Power Supply	Volts/Ph/Freq	460/3/60		
Minimum Circuit Ampacity	Amps	14.7	19.1	23.1
Maximum Overcurrent Protection	Amps	20	30	35
Compressor HP	HP	5	7	9
Compressor RLA	Amps	10	12.8	16
Fan Quantity		2	3	3
Fan HP	HP	1/4	1/4	1/2
Fan RLA	Amps	0.95	0.95	1.6
Approximate Weight	lb (kg)	1570	1590	1795

¹Refer to Nominal Inlet and Ambient Conditions

²Refer to unit data plate to confirm charge and refrigerant type

³Within CAGI permitted tolerance

NOTICE - Specification information above accurate at time of publication.

15.0 CORRECTION FACTORS

Inlet Pressure Correction Factor (IPCF)					
Inlet Pressure (PSIG)	300	400	500	600	680
Correction Factor	0.93	0.95	0.98	0.99	1

Inlet Temperature Correction Factor (ITCF)						
Inlet Temperature (°F)	70	80	90	100	110	120
Correction Factor	1.8	1.4	1.2	1	0.8	0.7

How to Apply Correction Factors		
Inlet Pressure Correction	500 PSIG	0.98
Inlet Temperature Correction	110 °F	0.8
Customer Airflow	1400 SCFM	

$$\text{Dryer Capacity} = \frac{\text{Customer Airflow}}{\text{IPCF} * \text{ITCF}}$$

$$\text{Dryer Capacity} = \frac{1400\text{SCFM}}{0.98 * 0.8} = \sim 1785 \text{ SCFM}$$



A series of horizontal lines spanning the width of the page, providing a template for writing. The lines are evenly spaced and extend from the left margin to the right edge of the page.



A series of horizontal lines for writing, consisting of 25 evenly spaced lines extending across the width of the page.



A series of horizontal lines spanning the width of the page, providing a template for writing. The lines are evenly spaced and extend from the left margin to the right edge of the page.

