

VMAC[®]

AIR INNOVATED[®]



Hydraulic Driven Air Compressor Installation and Owner's Manual (Includes Service Instructions)

Open Center Hydraulic System

www.vmacair.com

Table of Contents

General Information	3
Safety	4
Safety Precautions.....	5
Warranty	8
Installation Considerations.....	13
Mounting Locations and Ventilation.....	14
Speed Control	16
Hydraulic Requirements.....	17
Hydraulic Fluid and Line Sizing Recommendations.....	19
Hydraulic Driven Air Compressor Harness Reference	22
Electrical Schematic 12 V dc (H400001, H400004, H600002/4/8)	24
Electrical Schematic 12 V dc (H400010/18, H600014)	25
Electrical Requirements (12 V dc Systems)	26
Electrical Schematic 24 V dc (H400003, H400017)	28
Electrical Requirements (24 V dc Systems)	29
Installing the Hydraulic Driven Air Compressor System.....	30
Testing the Installation	33
Performance Testing and System Adjustments	35
Hydraulic Driven Air Compressor Owner's Manual.....	37
Identifying Your System.....	39
System Components and Specifications.....	40
System Operation	
(What to Expect at Start Up)	47
Cold or Hot Weather Operation.....	50
Display Box Messages	51
System Adjustments (Diagnostics Mode).....	53
Limp Mode	55
Maintenance Schedule and General Maintenance Information.....	56
Maintenance and Repair Safety	59
Regular Inspection Instructions	60
General Service Information.....	64
500 Hour / 1 Year Service.....	65
Diagnostics and Troubleshooting.....	72
Hydraulic Testing	81
Air Receiver Tank	85
Recommended Accessories	86
Accessory Products from VMAC.....	87
Error and Service Logs	90
Warranty Registration.....	92

Document: 1930366
 Changes and Revisions

Revision	Revision Details	Revised by	Checked by				Implemented
			Eng.		Tech.	Qual.	
			Mech.	Elec.			
F	ECN: 22-101 Update elect./hyd. requirements.	MSP	GJM	SRD	MSP	N/A	6 Jul 2022
G	ECN: 24-049 Add H400017 to manual	MSP	GJM	N/A	MSP	LPH	19 Mar. 2024
H	ECN: 24-053 Add H400018 and H600014	MSP	SPT	CAB	MSP	N/A	5 Apr. 2024

Additional Application Information

This manual applies to: H400001 | H400003 | H400004 | H400010 | H400017 | H400018 | H600002 | H600004 | H600008 | H600014.

- Not compatible with "load sensing" variable displacement pumps.
- Requires VMAC Closed Center Manifold if used with "pressure compensated" variable displacement pumps.

Registered Trademarks

All trademarks mentioned in this manual are the property of their respective owners. VMAC's use of manufacturers' trademarks in this manual is for identification of the products only and does not imply any affiliation to, or endorsement of said companies.

Loctite®, **Loctite® 242** and **Loctite® 567** are registered trademarks of Henkel AG & Company KGaA.

Eaton Aeroquip® is a registered trademark of EATON AEROQUIP INC.

Viton® is a registered trademark of The Chemours Company.

Important Information

The information in this manual is intended for certified VMAC installers who have been trained in installation and service procedures and/or for anyone with mechanical trade certification who has the tools and equipment to properly and safely perform the installation or service. Do not attempt installation or service without the appropriate mechanical training, knowledge and experience.

Follow all safety precautions. Any fabrication for correct fit in modified vehicles must follow industry standard "best practices".

Notice

Copyright © 2021 VMAC Global Technology Inc. All Rights Reserved. These materials are provided by VMAC for informational purposes only, without representation or warranty of any kind, and VMAC shall not be liable for errors or omissions with respect to the materials. The only warranties for VMAC products and services are those set forth in the express warranty statements accompanying such products and services, if any, and nothing herein shall be construed as constituting an additional warranty. Printing or copying of any page in this document in whole or in part is only permitted for personal use. All other use, copying or reproduction in both print and electronic form of any part of this document without the written consent of VMAC is prohibited. The information contained herein may be changed without prior notice.

Printed in Canada

VMAC - Vehicle Mounted Air Compressors

VMAC Technical Support: 888-241-2289

VMAC Knowledge Base: kb.vmacair.com

General Information



VMAC is unable to provide hydraulic circuit designs or consult on specific hydraulic installations. We recommend working with a local hydraulic expert to design and/or install the hydraulic circuit that will power the Hydraulic Driven Air Compressor system.

Introduction

This manual provides operating instructions, specifications, adjustment, maintenance and warranty information for the VMAC Hydraulic Driven Air Compressor systems. Read this manual prior to servicing or operating the compressor system.

Follow all safety precautions when servicing or operating the VMAC system as moving fan blades and other rotating components pose an extreme hazard.

Proper service and repair are important to the safety of the operator and the safe, reliable operation of the equipment. Always use genuine VMAC replacement parts.

The procedures described in this manual are the only approved methods of service and operation.

Ordering Parts

To order parts, contact a VMAC dealer. The dealer will ask for the VMAC System ID (see page 39), part number, description and quantity. Locate the nearest dealer online at www.vmacair.com/dealer-locator or call (877) 912-6605.



Additional Support

Additional resources such as installation manuals, illustrated parts lists, the VMAC Knowledge Base, air tool consumption guides, etc. are available at

<https://www.vmacair.com/support/>.



Safety

Important Safety Notice

The information contained in this manual is based on sound engineering principles, research, extensive field experience and technical information. Information is constantly changing with the addition of new models, assemblies, service techniques and running OEM changes. If a discrepancy is found in this manual, contact VMAC Technical Support prior to initiating or proceeding with installation, service or repair. Current information may clarify the issue. Anyone with knowledge of such discrepancies, who proceeds to perform service and repair, assumes all risks.

Only proven service procedures are recommended. Anyone who departs from the specific instructions provided in this manual must first ensure that their safety and that of others is not being compromised, and that there will be no adverse effects on the operational safety or performance of the equipment.

VMAC will not be held responsible for any liability, consequential damages, injuries, loss or damage to individuals or to equipment as a result of the failure of anyone to properly adhere to the procedures set out in this manual or standard safety practices.

Safety should be the first consideration when performing any service operations. If there are any questions concerning the procedures in this manual, or more information is required, please contact VMAC Technical Support prior to beginning work.

Safety Messages

This manual contains various warnings, cautions and notices that must be observed to reduce the risk of personal injury during installation, service or repair and the possibility that improper installation, service or repair may damage the equipment or render it unsafe.



This symbol is used to call attention to instructions concerning personal safety. Watch for this symbol; it points out important safety precautions, it means, "Attention, become alert! Your personal safety is involved". Read the message that follows and be aware of the possibility of personal injury or death. As it is impossible to warn of every conceivable hazard, common sense and industry standard safety practices must be observed.



This symbol is used to call attention to instructions on a specific procedure that if not followed may damage or reduce the useful life of the compressor or other equipment.



This symbol is used to call attention to additional instructions or special emphasis on a specific procedure.

Safety Precautions



As it is impossible to warn of every possible hazard that may result from operating this system, common sense and industry standard safety practices must be observed.

Read this information before operating the compressor for the first time. Follow the information and procedures in this manual for operation, maintenance and repair. Observe the following items to reduce the chance of personal injury or equipment damage.

Follow all safety precautions for mechanical work. Moving belts and rotating components are an extreme hazard. Stay clear of all moving parts when the system is operating. Only qualified personnel should perform maintenance and repair on system components and only while the system is properly shut down.

Proper service and repair are important to the safety of the service technician and the safe, reliable operation of the equipment. Always use genuine VMAC replacement parts.

The procedures described in this service manual are effective methods of service and repair. Some procedures may require the use of tools specially designed for a specific purpose. Anyone using a replacement part, service procedure or tool must first determine that neither their safety nor the safe operation of the equipment will be compromised by the replacement part, service procedure or tool selected.



Burn Hazard





- The compressor system gets very hot during operation, contact with the components or the oil can cause serious injury. Allow sufficient time for the system to cool before performing service.
- Never allow any part of your body to contact the compressor components.



Personal Safety

- Do not breathe the compressor air. Vaporized oil is a respiratory hazard.
- Always use the appropriate personal protective equipment, particularly eye and hearing protection when operating air powered equipment.



 	<h3>Fire and Explosion Hazard</h3> <ul style="list-style-type: none"> • Vaporized oil propelled by high pressure air is an explosive mixture. • Fire in the compressor can cause an explosion and flame projection. Should this occur, there is potential for serious injury or death. • Operate the compressor in a well ventilated area free of flammable vapors, dust, or other combustible materials. • Never place objects against or on top of the compressor. • Never expose the Air Oil Separator Tank or compressor to extreme heat.
	<h3>Compressor Air and Oil Hazard</h3> <ul style="list-style-type: none"> • The compressor system is under sufficient pressure that a leak could force the air/oil mixture through the skin directly into your bloodstream. This could cause serious injury or death. • Ensure the system is completely depressurized before attempting maintenance or repair. • Do not use compressed air to clean off clothing or skin, compressed air can penetrate the skin causing serious injury or death. • Do not move or service the compressor while it is pressurized or operating. • Do not move the compressor by pulling on any hoses. • Components and hoses under pressure could separate suddenly, fly out and cause serious injury or death. If equipped, the air receiver tank must be drained before servicing any components in the compressor system. • Never adjust or attempt to make any repairs to the system while the engine is running. Components and hoses under pressure could fail and cause serious injury or death.
	<h3>Burst Hazard</h3> <ul style="list-style-type: none"> • Serious injury or death may result from an air tank explosion. • Never exceed manufacturer's maximum air pressure rating. • Do not repair components, only replace with approved parts. • Do not tamper with or disable factory safety equipment.
	<h3>Moving Parts Hazard</h3> <ul style="list-style-type: none"> • Before performing service, disconnect the negative battery cable and the spark plug wire to prevent unexpected engine start. • Do not operate the compressor without guards in place. If the guards are damaged or missing, replace them before operating the equipment.

General Warnings



- Ensure the compressor and hydraulic system are cool and depressurized prior to servicing.
- Be attentive for unexplained changes in operation parameters and record any changes.
- Check the compressor oil level and condition before starting the system. Do not add or change oil while the system is running. Use only approved oil.
- The compressor may operate anytime the hydraulic circuit is energized. Avoid contact with the compressor, hoses, or motor during operation.
- Keep hoses and wiring away from hot, sharp, or moving components.
- Use only approved hoses and replacement parts.
- Do not modify the equipment.
- Do not operate the air compressor when fatigued or under the influence of alcohol or drugs.
- Know how to operate the compressor, fully read the manual.
- Check equipment before every use.
- Never bypass or disable any of the safety equipment.
- Never adjust or attempt to make any repairs to the compressor system while the hydraulic circuit is pressurized. Components and hoses under pressure could fail and cause serious injury or death.

Warranty

VMAC Standard Warranty (Limited)

For complete warranty information, including both VMAC Standard Warranty (Limited) and VMAC Lifetime Warranty (Limited) requirements, please refer to our current published warranty located at: www.vmacair.com/warranty



If you do not have access to a computer, please contact us and we will be happy to send you our warranty.

VMAC's warranty is subject to change without notice.

VMAC Lifetime Warranty (Limited)

A VMAC Lifetime Limited Warranty is offered on the base air compressor only and only on UNDERHOOD®, Hydraulic Driven, Transmission Mounted, Gas and Diesel Engine Driven Air Compressors, Multifunction Power Systems, and other products as defined by VMAC, provided that (i) the purchaser fully completes and submits a warranty registration form within 3 months of purchase, or 200 hours of operation, whichever occurs first; (ii) services are completed in accordance with the Owner's Manual; (iii) proof of purchase of applicable service kits are made available to VMAC upon request.



The VMAC Lifetime Warranty is applicable to new products shipped on or after 1 October, 2015.

Warranty Registration

The VMAC warranty registration form is located near the back of this manual. This warranty registration form must be completed and sent to VMAC at the time of installation for any subsequent warranty claim to be considered valid.

There are 4 ways the warranty can be registered with VMAC:



<https://www.vmacair.com/support/warranty-registration>



warranty@vmacair.com



(877) 740-3202



VMAC - Vehicle Mounted Air Compressors
1333 Kipp Road, Nanaimo, BC, Canada V9X 1R3

VMAC Warranty Claim Process



VMAC warranty work must be pre-authorized by VMAC. Claims are processed via our dealer network. If you are not a VMAC dealer, please select one to work with via our Dealer Locator: <https://www.vmacair.com/support/find-a-dealer>



- 1) Communicate with VMAC Technical Support at [\(888\) 241-2289](tel:8882412289) or tech@vmacair.com to help diagnose/troubleshoot the problem prior to repair. VMAC technical support will require the VMAC System ID, and hours on the compressor.
- 2) VMAC will provide direction for repair or replacement of the failed components.
- 3) If requested, failed parts must be returned to VMAC for evaluation.
- 4) Dealers may login to the VMAC website to view the "VMAC Labour Time Guide" (under "Agreements") to see the allowable warranty labour times.
- 5) Warranty invoices must include the Service Ticket number, VMAC System ID#, hours on the compressor, and a detailed description of the work performed.
- 6) VMAC Warranty does not cover consequential damages, loss of income, overtime charges, mileage, travel time, towing/recovery, cleaning or shop supplies.
- 7) Dealers submit warranty claims on behalf of the Vehicle Owner/End User affected by the defective part(s). The dealer ensures that all warranty credits are refunded back to the Vehicle Owner/End User who made the initial warranty claim.



In order to qualify for Lifetime Warranty (Limited), the completed warranty registration form must be received by VMAC within 3 months of the buyer receiving the Product(s), or 200 hours of operation, whichever occurs first.

If the completed warranty registration form has not been received by VMAC within 3 months of the buyer receiving the Product(s), or 200 hours of operation, the "Standard" warranty period will be deemed to commence 30 days from the date of shipment from VMAC.

Failure to follow the warranty claim process may result in denial of the warranty claim.

VMAC Product Warranty Policies & Warranty Registration can be found on the VMAC website (see previous page for URL).

VMAC[®]

AIR INNOVATED[®]



Hydraulic Driven Air Compressor Installation Manual

Installation Considerations



The information in this section is critical to ensure proper operation of the system. Read these requirements prior to beginning the installation.

Failure to adhere to these recommendations will cause the Hydraulic Driven Air Compressor system to operate erratically.

Prior to installing the system, consider the following factors:

- For proper operation, VMAC's Hydraulic Driven Air Compressor Systems require proper hydraulic pressure and flow, ensure the hydraulic circuit is designed with these requirements in mind (see page 17).
- See "Hydraulic Fluid and Line Sizing Recommendations" on page 19 for additional hydraulic circuit recommendations.
- Special consideration is required for variable rate hydraulic pumps (see page 17). Is the intended location convenient for electrical, hydraulic, and air connections?
- Will the intended location require extensive plumbing for the hydraulic system or air hoses?
- Are the wire lengths, and air/hydraulic hose lengths as short as possible, and with the least amount of 90° fittings possible?
- Can the oil level at the sight glass be checked easily?
- Can the unit be serviced easily?
- Will there be adequate clearance around the unit to provide good air circulation and effective cooling (see page 14)?
- Will the unit be protected from excessive exposure to the elements?
- Will the unit be protected from incidental damage from other operations?
- Will the unit be mounted away from heat sources such as engines, exhaust, or other components that can generate heat.
- Will the unit be mounted where it will be exposed to high contamination levels, including combustible gases?
- If the intended mounting location is constructed of thin gauge material, consider using the VMAC Mounting Brackets (P/N: A700140).



The integrated cooler on the Hydraulic Driven Air Compressor system is capable of removing all of the heat generated during air compression from the compressor oil and hydraulic fluid.

Additional hydraulic oil cooling (such as VMAC's Hydraulic Oil Cooler (P/N: A850001) may be required for any other hydraulic equipment is installed on the same circuit.

Mounting Locations and Ventilation

Top Mounting

"Top mounted" is the preferred mounting location for the Hydraulic Driven Air Compressor. Placing the unit on top of the service body provides the best access to cool fresh air. Maintain a minimum of 6 in between the sides of the Hydraulic Driven Air Compressor and all other solid objects (Figure 1).



VMAC does not recommend mounting the unit at the back of the vehicle as the drag created when the vehicle is moving causes debris to be deposited (and accumulated) inside the unit.

Enclosed Mounting



Enclosed mounting is not recommended due to the significant heat generated by the Hydraulic Driven Air Compressor.

Mounting the Hydraulic Driven Air Compressor in an enclosure will limit access to cool fresh air, restrict the escape of hot air from around the unit and have an adverse effect on cooling which may reduce the unit's duty cycle. Ensure adequate ventilation is provided for cooling and to evacuate the heat generated by the unit. If mounting in an enclosure, VMAC strongly recommends mounting the unit on a pullout drawer and extending the drawer any time the unit is run.

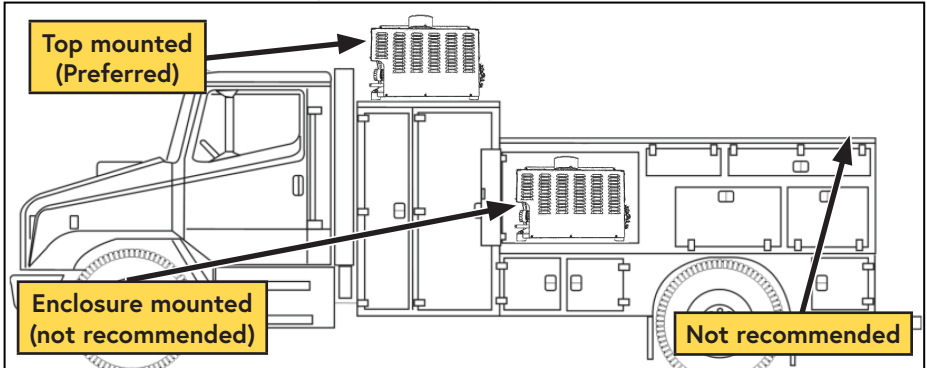

Figure 1 — Mounting locations

While it is not possible to make absolute recommendations regarding ventilation due to the widely differing circumstances that are possible, duty cycle, ambient temperature and enclosure shape are some of the important variables that must be considered.



Significant ventilation and additional cooling will be required if the Hydraulic Driven Air Compressor is mounted in the same enclosure as the hydraulic oil reservoir. The heat generated during operation will continue to heat the hydraulic fluid (even with fresh ambient air entering the cooler).

Recommended Component Layout

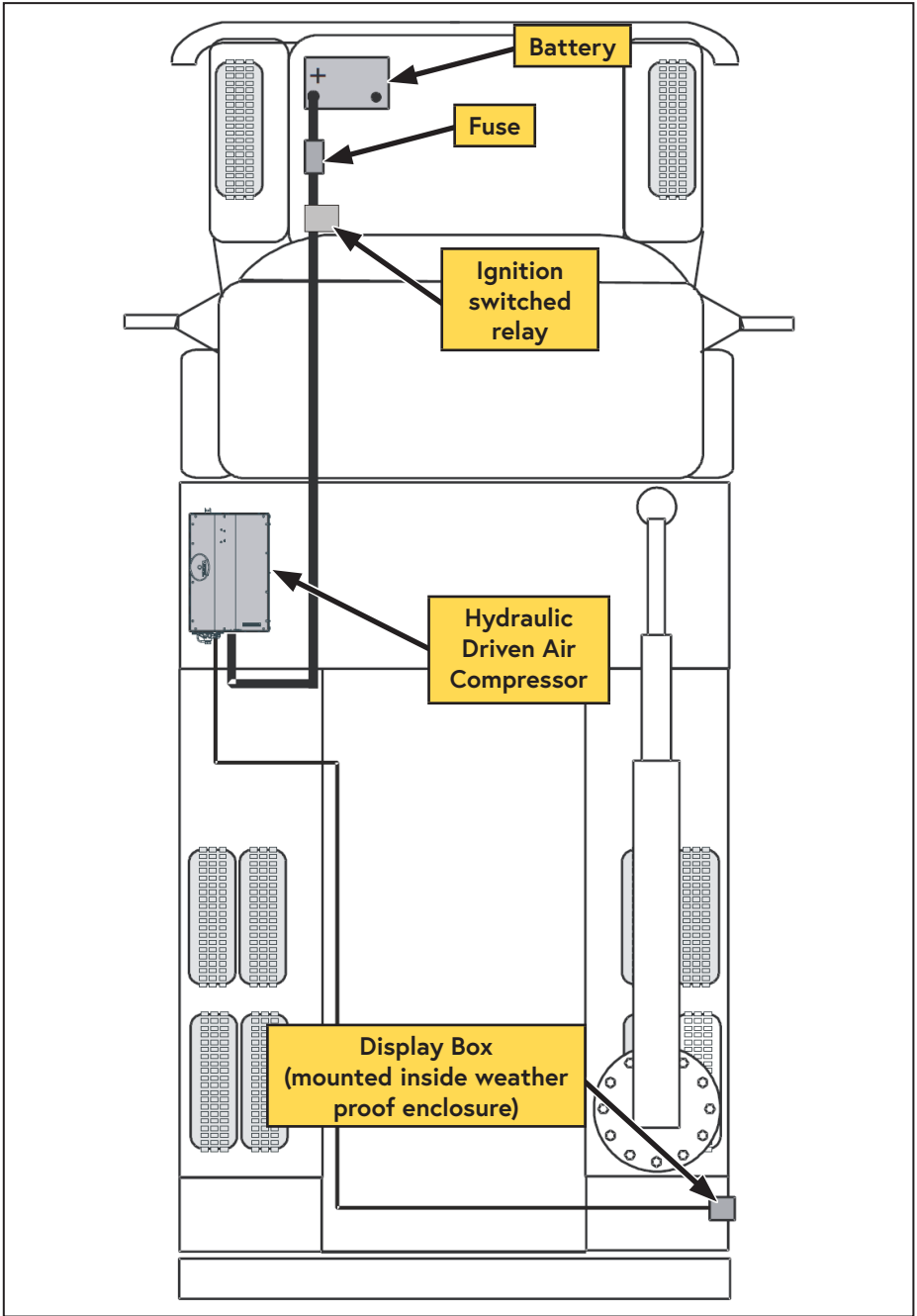

Figure 2 — Recommended component layout

Speed Control

The Hydraulic Driven Air Compressor has the ability to signal for a higher engine speed under high air demand conditions and for a lower engine speed under low air demand conditions. A built in, electrically activated idle up system or an after-market product is required to provide 2 speed operation.

The Hydraulic Driven Air Compressor is capable of constant operation at a fixed engine speed and hydraulic pump gpm.

There are several advantages to configuring the system for 2 speed operation:

- Lower fuel consumption.
- Lower noise when air demand is low.
- Lower wear rates on the engine, hydraulic pump and compressor.
- Faster warm up during cold start weather.

The preferred approach for speed control is to restrict the hydraulic flow to the Hydraulic Driven Air Compressor to the minimum requirement for the system (8 – 9 gpm for the H40, 13 – 14 gpm for the H60 and H60 HHP) this is desirable for cold climate start-up as it keeps hydraulic pressure low during warm up.



The system must be at, or above, the minimum hydraulic flow before starting the Hydraulic Driven Air Compressor.

Single Speed Operation (See Figure 3 on page 17 for "gpm vs cfm" chart)

When the "ON" button is pressed, the control box in the Hydraulic Driven Air Compressor will signal the PTO to increase hydraulic flow to provide the desired cfm.

2 Speed Operation (See Figure 3 on page 17 for "gpm vs cfm" chart)

When the "ON" button is pressed, "Speed 1" is activated and the control box in the Hydraulic Driven Air Compressor will signal the PTO to set hydraulic flow to the minimum desired cfm.

"Speed 2" is activated to signal the PTO to increase hydraulic flow to provide the maximum cfm (or speed system warm up).

Remote ON/OFF Control (Optional)

The system can be configured with a remote "ON/OFF" control by connecting the yellow remote wire on the harness to a switch or relay and connecting the other side of the switch or relay to ground. The Hydraulic Driven Air Compressor will turn on when the circuit between the yellow wire and ground is completed via the switch or relay and will turn off when the switch or relay is used to open the circuit.

H400010/18, H600014 only: The remote "ON/OFF" control wire (orange) is included in the upfitter connection and the relay is located inside the unit. Supplying +12 V to the orange wire turns the compressor on.

All systems: When using the remote "ON/OFF" wire, the display box can only be used to view messages as the "ON" and "OFF" buttons are disabled.

Hydraulic Requirements



VMAC's Hydraulic Driven Air Compressors are designed to be driven by fixed displacement hydraulic pumps.

Hydraulic circuits using "pressure compensated" variable displacement pumps must have a Closed Centre Manifold installed at the Hydraulic Driven Air Compressor (see "Accessory Products from VMAC" on page 87).

VMAC's Hydraulic Driven Air Compressors are not compatible with "load sensing" variable displacement hydraulic pumps.



VMAC is unable to provide hydraulic circuit designs or consult on specific hydraulic installations. We recommend working with a local hydraulic expert to design and/or install the hydraulic circuit that will power the Hydraulic Driven Air Compressor system.

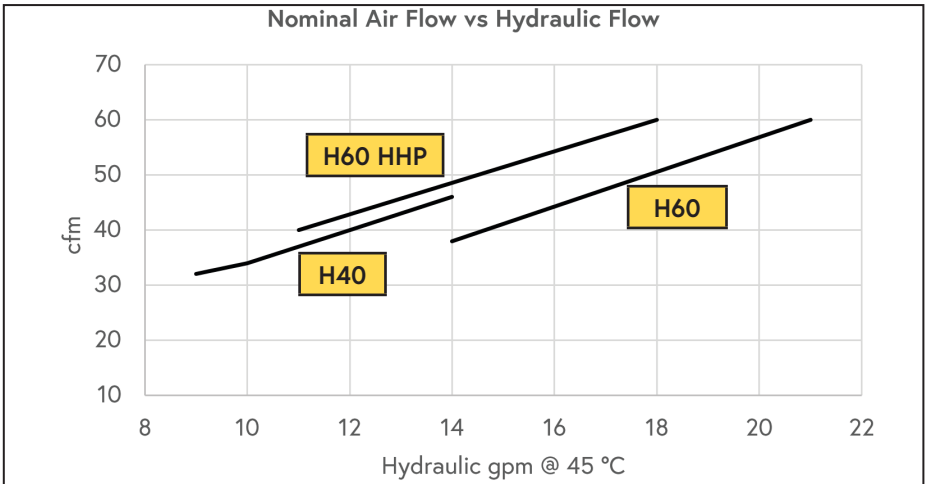

Figure 3 — cfm vs gpm

H40 / H60

While in operation, the required system pressure will vary between 900 psi and 2,400 psi.

The hydraulic pump must be rated for 2,400 psi (steady state) and 2,800 psi (intermittent) to allow for an additional 200 psi pressure drop in the pressure lines (external to the system) during startup with cold hydraulic fluid.

H60 HHP

While in operation, the required system pressure will vary between 900 psi and 2,700 psi.

The hydraulic pump must be rated for 3,200 psi (steady state) and 3,400 psi (intermittent) to allow for an additional 200 psi pressure drop in the pressure lines (external to the system) during startup with cold hydraulic fluid.

VMAC - Vehicle Mounted Air Compressors

VMAC Technical Support: 888-241-2289

VMAC Knowledge Base: kb.vmacair.com

Hydraulic40

The system must maintain hydraulic flow between 9 gpm and 14 gpm (Figure 3).

Hydraulic60

The system must maintain hydraulic flow between 14 gpm and 21 gpm (Figure 3).

Hydraulic60 HHP

The system must maintain hydraulic flow between 12 gpm and 18 gpm (Figure 3).

The stated hydraulic flow rates are nominal values only and may change due to variations in hydraulic system efficiency, load, and flow. Tests should be performed to confirm that the desired cfm has been achieved.

If the Hydraulic Driven Air Compressor system is being installed into an existing hydraulic circuit, ensure the circuit meets the requirements listed in this chapter.

See "Hydraulic Fluid and Line Sizing Recommendations" on page 19 for additional information.

Filtration

VMAC recommends that the hydraulic circuit meet or exceed ISO Code 16/13, SAE Class 4.



An independent hydraulic system is recommended to simplify installation, operation, and troubleshooting of the Hydraulic Driven Air Compressor system.

If this system is being installed in a shared hydraulic circuit, the use of a shut off valve is advised.

Hydraulic Fluid and Line Sizing Recommendations



VMAC is unable to provide hydraulic circuit designs or consult on specific hydraulic installations. We recommend working with a local hydraulic expert to design and/or install the hydraulic circuit that will power the Hydraulic Driven Air Compressor system.

The following information is intended as a guideline only.

Climate / Temperature Reference Chart

Extreme Cold Climate	Cold Climate	Temperate Climate
Below -4 °F (-19 °C)	-3 °F — 32 °F (-19 °C — 0 °C)	Above 32 °F (0 °)

Table 1 — Temperature reference chart

Hydraulic Fluid Type



Use only premium quality mineral or synthetic anti wear hydraulic fluid.

When selecting which hydraulic fluid to use, the decision should be based on the lowest overnight temperature that the unit will be used in.

Cold Climate	Temperate Climate
AW22 †	AW32
† When possible change to AW32 (e.g. during summer months)	

Table 2 — Hydraulic fluid chart

Mount Location	Extreme Cold Climate
Tank and Suction Line Preheat	AW32
No Tank Preheat	A seasonal hydraulic fluid change is recommended.

Table 3 — Hydraulic fluid recommendation for extreme cold climates

Hydraulic Line Sizing

Industrial hydraulic system design guidelines generally call for the following maximum fluid velocities, which are then used to select line sizes for any particular gpm:

- Supply 4 ft/sec.
- Return 10 ft/sec (maximum return line pressure should be in the 50 psi - 70 psi range).
- Pressure 20 ft/sec.

The above guidelines are not considered comprehensive when working with mobile hydraulic applications on prebuilt chassis due to the following factors:

- Extreme start-up temperature variations.
- Long supply lines.
- Piggy-backing of motor case drain flow onto the main return line.



Hydraulic pump failure due to cavitation, and/or hydraulic motor seal failure due to excess return line pressure, may occur if the above considerations are ignored when line sizes are being determined.

The following information provides specific line sizing recommendations for mobile hydraulic system installations intended for use with VMAC's Hydraulic Driven Air Compressor systems. The dimensions provided indicate "inside diameter" (ID).

Supply Line Sizing



Failure to use the correct suction line size may result in hydraulic pump cavitation leading to premature pump failure.

- In order to determine the appropriate supply line size, first identify the climate that the system will be used in (Table 1), then select the corresponding line size based off of the maximum gpm of the system (Table 4 or Table 5 starting on page 21).



Special design considerations are required for hydraulic systems operating in extreme cold climates. VMAC recommends consulting with hydraulic experts experienced in the design and installation of hydraulic circuits that will be used in temperatures below -4 °F (-19 °C).

gpm during start up / warm up	Supply Line Size AW 22	Supply Line Size AW 32
Up to 8 gpm	1 in (up to 1 ft) 1 1/4 in (up to 2 1/2 ft) 1 1/2 in (up to 6 ft) 1 3/4 in (up to 9 ft) 2 in (above 9 ft)	1 1/4 in (up to 1 ft) 1 1/2 in (up to 2 1/2 ft) 1 3/4 in (up to 3 1/2 ft) 2 in (up to 8 ft) 2 1/2 in (above 8 ft)
12 gpm	1 1/4 in (up to 1 1/2 ft) 1 1/2 in (up to 4 ft) 1 3/4 in (up to 6 ft) 2 in (up to 12 ft) 2 1/2 in (above 12 ft)	1 1/2 in (up to 1 1/2 ft) 1 3/4 in (up to 2 1/2 ft) 2 in (up to 5 ft) 2 1/2 in (up to 13 ft) 3 in (above 13 ft)
16 gpm	1 1/2 in (up to 3 ft) 1 3/4 in (up to 4 1/2 ft) 2 in (up to 9 ft) 2 1/2 in (above 9 ft)	1 1/2 in (up to 1 ft) 1 3/4 in (up to 2 ft) 2 in (up to 4 ft) 2 1/2 in (up to 10 ft) 3 in (above 10 ft)
21 gpm	1 1/2 in (up to 2 ft) 1 3/4 in (up to 3 1/2 ft) 2 in (up to 7 ft) 2 1/2 in (above 7 ft)	1 1/2 in (up to 1 ft) 1 3/4 in (up to 1 1/2 ft) 2 in (up to 3 ft) 2 1/2 in (up to 8 ft) 3 in (above 8 ft)

Table 4 — Cold climate

gpm during start up / warm up	Supply Line Size AW 22	Supply Line Size AW 32
Up to 8 gpm	1 in (up to 4 ft) 1 1/4 in (up to 8 ft) 1 1/2 in (above 8 ft)	1 in (up to 1 1/2 ft) 1 1/4 in (up to 4 ft) 1 1/2 in (up to 9 ft) 1 3/4 in (above 9 ft)
12 gpm	1 1/4 in (up to 5 ft) 1 1/2 in (up to 11 ft) 1 3/4 in (above 11 ft)	1 1/4 in (up to 2 1/2 ft) 1 1/2 in (up to 6 ft) 1 3/4 in (up to 9 ft) 2 in (above 9 ft)
16 gpm	1 1/2 in (up to 9 ft) 1 3/4 in (up to 13 ft) 2 in (above 13 ft)	1 1/2 in (up to 4 ft) 1 3/4 in (up to 7 ft) 2 in (up to 14 ft) 2 1/2 in (above 14 ft)
21 gpm	1 1/2 in (up to 7 ft) 1 3/4 in (up to 11 ft) 2 in (above 11 ft)	1 1/2 in (up to 2 1/2 ft) 1 3/4 in (up to 5 ft) 2 in (up to 11 ft) 2 1/2 in (above 11 ft)

Table 5 — Temperate climate

Pressure and Return Line Sizing

Pressure Line Size	Return Line Size
3/4 in	1 in

Table 6 — Pressure and return line size

Hydraulic Driven Air Compressor Harness Reference

Installer Interface (Except H400010 | H400018 | H600014)

Colour	Pin	Function	Notes
Purple	A	High Idle Output	Ground switching signal, use to supply ground to relay or equivalent
Green	B	System Ground	0 Ω
Red	C	System Power	+12 V (H400003/17: +24 V)

Remote Switch Wire (Except H400010 | H400018 | H600014)

Colour	Pin	Function	Notes
Yellow	—	Remote Enable Wire	Ground wire to run compressor

Installer Interface (H400010 | H400018 | H600014)

Colour	Pin	Function	Notes
Blue	4	High Idle Output	High Side switching signal, use to supply +12 V to relay or equivalent.
Green	2	System Ground	0 Ω
Red	1	System Power	+12 V
Orange	3	Remote Enable Wire	+12 V in the upfitter connection to run compressor

Display Box

Colour	Pin	Function	Notes
Red	A	Display +12 V	+12 V
Green	B	Display Ground	0 Ω
White	C	CAN Hi	CAN bus signal
Black	D	CAN Low	CAN bus signal

Air Solenoid

Colour	Pin	Function	Notes
Red	1	+12 V Supply	+12 V
Black	2	Switched Ground	Switched

Hydraulic Solenoid

Colour	Pin	Function	Notes
Red	A	Switched Ground	Switched
Red	B	+12 V Supply	+12 V

Fan Motor			
Colour	Pin	Function	Notes
Red	A	Relay Switched +12 V	+12 V (H400003/17: +24 V)
Green	B	System Ground	0 Ω

Fan Relay			
Colour	Pin	Function	Notes
Red	5 (85)	System Power	+12 V
Orange	2 (86)	Switched Ground	Switched
Red	4 (87)	Relay Switched +12 V	(To fan motor) +12 V (H400003/17: +24 V)
Red	1 (30)	System Power	+12 V (H400003/17: +24 V)

Compressor Temperature Probe			
Colour	Pin	Function	Notes
White	A	Thermistor Signal Voltage	Varies with temperature - see thermistor resistance tables for further diagnosis.
White	B	Thermistor Signal Voltage	Varies with temperature - see thermistor resistance tables for further diagnosis.

Hydraulic Temperature Probe			
Colour	Pin	Function	Notes
White	A	Thermistor Signal Voltage	Varies with temperature - see thermistor resistance tables for further diagnosis.
White	B	Thermistor Signal Voltage	Varies with temperature - see thermistor resistance tables for further diagnosis.

System Pressure Sensor			
Colour	Pin	Function	Notes
Red	–	+5 V	+5 V
Green	–	Pressure Signal	+0.5 V – +4.5 V, 0 – 150 psi (ratiometric)
Black	–	Ground	0 Ω

Heater Solenoid (Cold Climate Kit P/N: A800070)			
Colour	Pin	Function	Notes
Blue	A	Switched Ground	Switched
Blue	B	+12 V Supply	+12 V

Table 7 — Harness reference chart

Electrical Schematic 12 V dc (H400001, H400004, H600002/4/8)

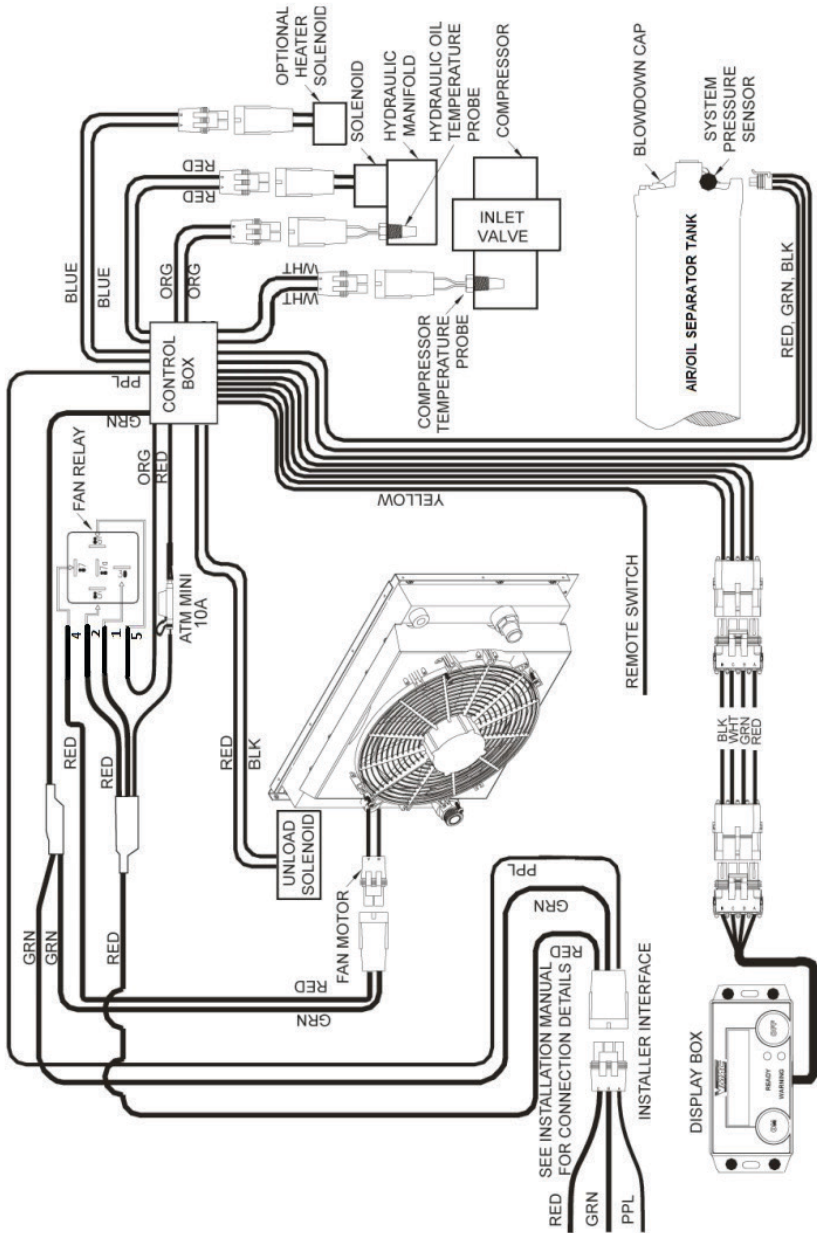

Figure 4 — Electrical schematic 12 V dc

Electrical Schematic 12 V dc (H400010/18, H600014)

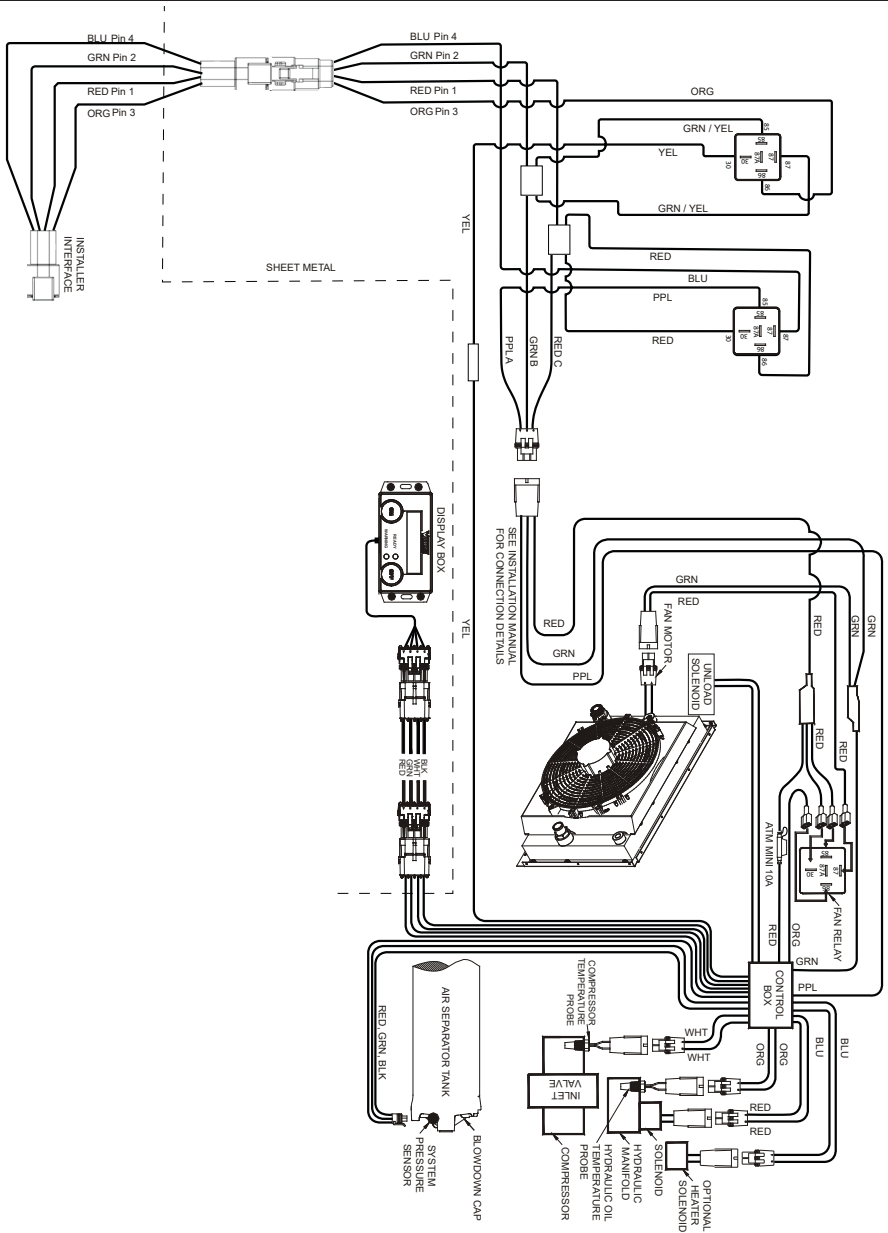

Figure 5 — Electrical schematic 12 V dc H400010/18, H600014

Electrical Requirements (12 V dc Systems)



The information in this section is critical to ensure proper operation of the system. Read these requirements prior to beginning the installation.

Failure to adhere to these recommendations will cause the Hydraulic Driven Air Compressor system to operate erratically.

VMAC's Hydraulic Driven Air Compressor systems require a steady 20 A at 12 V dc (nominal) to operate. A 30 A fuse or circuit breaker is recommended.

To ensure an uninterrupted supply of power, the ground wire should be routed either to the negative terminal of the battery or to a substantial, fully grounded point on the vehicle chassis. Confirm the selected ground is good by using an ohm meter to measure the resistance between the ground point and the negative battery terminal. Resistance should be less than 1 Ω .

The power supplied to the unit should be ignition switched through a relay to reduce the risk of battery drain when the engine is off. The main power should be supplied directly from the positive terminal of the battery via a relay. Using a relay allows the heavy gauge power wire to be routed directly and permits the use of a light gauge wire (e.g. 18 AWG) between the relay and the control switch.

Wire Sizing Guide 12 V Systems

Combined length of power and ground wires	Recommended wire gauge
Less than 10 ft (3 m)	12 AWG
Between 10 ft (3 m) and 18 ft (5.5 m)	10 AWG
18 ft (5.5 m) to a maximum of 35 ft (10.5 m)	8 AWG

Table 8 — Wire size table



VMAC does not recommend installing the system in a location that would require a combined wire length greater than 35 ft (10.5 m).

This page intentionally left blank

Electrical Schematic 24 V dc (H400003, H400017)

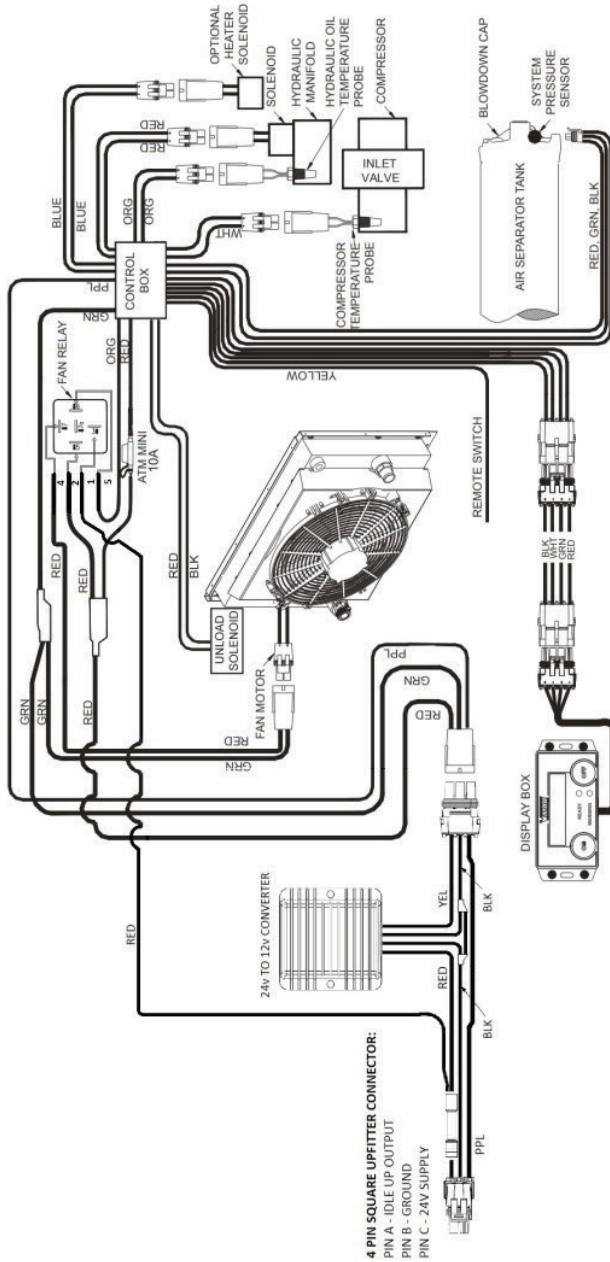

Figure 6 — Electrical schematic 24 V dc

Electrical Requirements (24 V dc Systems)



The information in this section is critical to ensure proper operation of the system. Read these requirements prior to beginning the installation.

Failure to adhere to these recommendations will cause the Hydraulic Driven Air Compressor system to operate erratically.

VMAC's Hydraulic Driven Air Compressor systems require a steady 15 A at 24 V dc (nominal) to operate. A 25 A fuse or circuit breaker is recommended.

The supplied power is run through a 24 V to 12 V converter. With the exception of the fan (which is supplied with 24 V), this is a 12 V system.

To ensure an uninterrupted supply of power, the ground wire should be routed either to the negative terminal of the battery or to a substantial, fully grounded point on the vehicle chassis. Confirm the selected ground is good by using an ohm meter to measure the resistance between the ground point and the negative battery terminal. Resistance should be less than 1 Ω .

The power supplied to the unit should be ignition switched through a relay to reduce the risk of battery drain when the engine is off. The main power should be supplied directly from the positive terminal of the battery via a relay. Using a relay allows the heavy gauge power wire to be routed directly and permits the use of a light gauge wire (e.g. 18 AWG) between the relay and the control switch.

Wire Sizing Guide 24 V Systems

Combined length of power and ground wires	Recommended wire gauge
Less than 10 ft (3 m)	14 AWG
Between 10 ft (3 m) and 18 ft (5.5 m)	12 AWG
18 ft (5.5 m) to a maximum of 35 ft (10.5 m)	10 AWG

Table 9 — Wire size table



VMAC does not recommend installing the system in a location that would require a combined wire length greater than 35 ft (10.5 m).

Installing the Hydraulic Driven Air Compressor System

Mounting the Unit

- Remove the unit from the packaging.
- Ensure the (x4) rubber isolator mounts remain fastened to the base of the unit.



Some hydraulic fluid will run out of the unit when the ORB fittings are removed, ensure all environmental regulations are adhered to.

- Remove the (x2) ORB plugs from the manifold on the side of the unit.
- Install suitable ORB fittings to connect the system to the hydraulic circuit.



Failure to mount the unit using the rubber isolators will result in considerable noise and vibration during operation.

- Remove the 3/4 in NPT plug from the AOST and install a suitable fitting to connect it to the downstream equipment (i.e. air receiver tank, hose reel, etc.).
- Mount the unit (Figure 5).
 - If using the VMAC Mounting Brackets (P/N: A700140), install them now.
 - If using the integral mounts, drill (x4) 13/32 in holes in the selected mounting location.

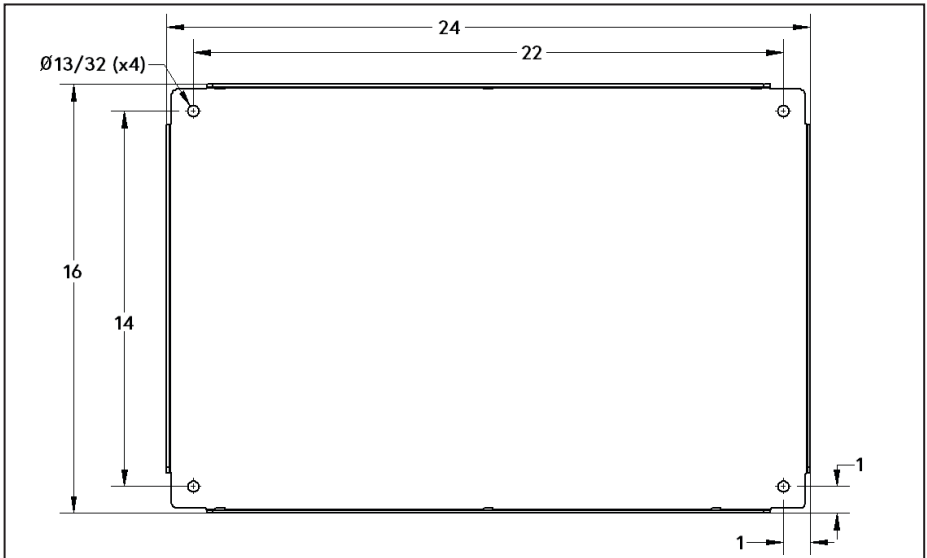

Figure 7 — Mounting dimensions (in inches)

- Apply Loctite 242 (blue) to the mounting studs and secure the unit in place.
- Connect the Hydraulic Driven Air Compressor to the hydraulic circuit.

- Connect the Hydraulic Driven Air Compressor to the hydraulic circuit.



The direction of hydraulic flow is critical. If reversed, high pressure may damage the system or burst a hose.

Connecting the Wiring (All except H400010/18, and H600014)



For wire size requirements for the power (red) and ground (green) wires, see Table 8 on page 26 (for 12 V systems) or Table 9 on page 29 (for 24 V systems).

As the purple wire used to enable the second speed is a signal wire, 18 AWG will be adequate.

Single Speed Configuration (Figure 8)

- Connect the green wire from the Hydraulic Driven Air Compressor system to ground.
- Splice the input from the throttle control to the red wire from the Hydraulic Driven Air Compressor system's power circuit.

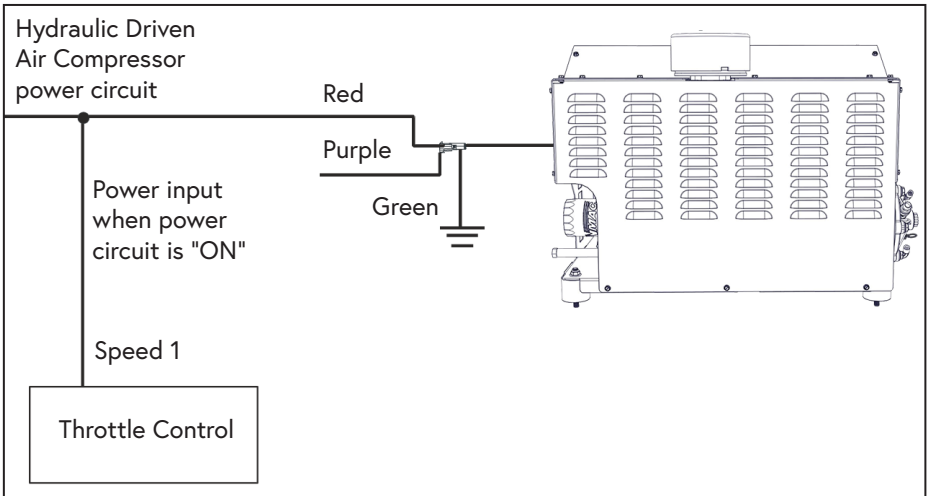

Figure 8 — Single speed configuration

2 Speed Configuration (Figure 9)

- Connect the green wire from the Hydraulic Driven Air Compressor system to ground.
- Connect the throttle control to the Hydraulic Driven Air Compressor system via a relay.

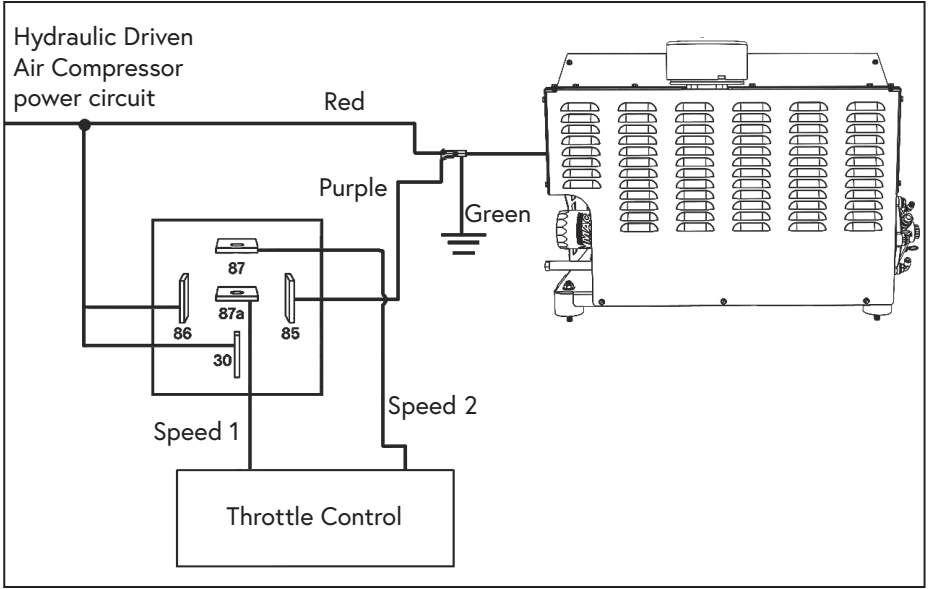

Figure 9 — 2 speed configuration

Testing the Installation



Ensure there are no people around the Hydraulic Driven Air Compressor prior to performing the following the test.



The VMAC supplied and approved compressor oil must be used in this system. Failure to use this special oil will result in damage to the compressor and will void the warranty.

Do not overfill the system. Overfilling the system with oil can flood the sight glass window and make the system appear empty.

Before Starting the System

- Verify the compressor oil is at the correct level (the system is filled at the factory but the level must be checked prior to operation).
- Verify the hydraulic fluid is at the correct level.
- Perform a final inspection to ensure that all:
 - Fasteners and connections are tight.
 - Hoses are secure and adequately protected.
 - Wiring is secure and adequately protected.
- Temporarily install a hydraulic flow meter with pressure gauge (see "Hydraulic Testing" on page 81) into the hydraulic circuit at the supply line to the Hydraulic Driven Air Compressor to confirm actual hydraulic flow.
- Install the VMAC Air Test Tool (A700152) with the appropriate orifice and the ball valve closed.



If the unit is vehicle mounted, ensure the vehicle is parked on level ground, the transmission is in "PARK", with the parking brake engaged.



If the ambient temperature is below -13 °F (-25 °C), warm the hydraulic fluid prior to activating the Hydraulic Driven Air Compressor.

After Engaging the Hydraulics

- Check the hydraulic circuit for leaks.
- Verify the hydraulic flow meets the minimum requirements for the system installed (page 17).
- Begin circulating hydraulic fluid.
- Turn the Hydraulic Driven Air Compressor on. See "What to Expect at Startup" on page 47.



On systems configured for 2 speed operation, the engine rpm should reduce to the second speed once full system pressure is achieved (factory default: 150 psi).



Always allow for efficiency loss as the hydraulic fluid heats up and adjust the gpm as required to ensure that the flow delivered at "Speed 1" does not drop below the minimum requirement.

- Open the ball valve on the VMAC Air Test Tool (if not using the VMAC Air test tool with the proper orifice, open the ball valve enough to maintain 100 psi) and operate the system for at least 1 hour at full load while monitoring the hydraulic flow and cfm output.
- Close the ball valve and allow the system to build to full system pressure.
- Turn the Hydraulic Driven Air Compressor off and allow the system to cool.
- Check the compressor oil level after the oil level has had time to stabilize.
- Check the hydraulic fluid level after the system has been shut down.
- Remove the Hydraulic test tool from the system.
- Restart the system and verify there are no leaks in the area where the hydraulic test tool was installed.

Performance Testing and System Adjustments



The cfm generated by the Hydraulic Driven Air Compressor is dependent upon the gpm delivered by the hydraulic circuit. The following test requires that the hydraulic circuit delivers the maximum gpm for the Hydraulic Driven Air Compressor model installed. Ensure any other hydraulic equipment installed on the circuit is either rated to accept the maximum hydraulic flow, or is adequately protected during testing (see "Hydraulic Requirements" on page 17).

Compressor Performance Testing

System operation can be tested using the tools that will be operated by the system or by using the VMAC Test Tool (A700052) with the appropriate orifice in the outlet to simulate tool use (Figure 10).

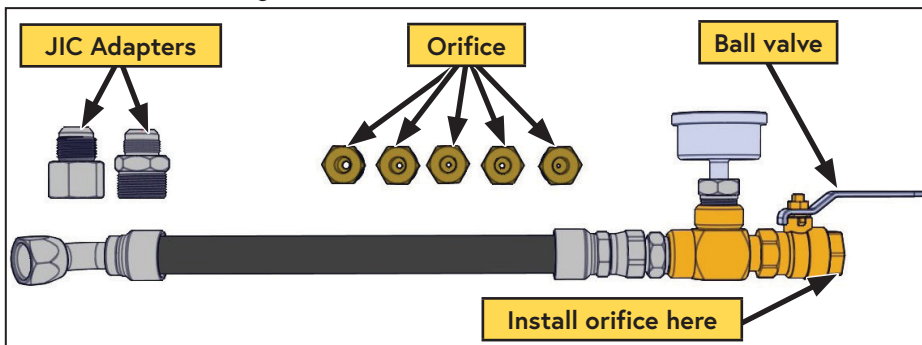

Figure 10 — A700052 VMAC Air Test Tool



Disconnect all downstream equipment (hose reels, etc.) and connect the test tool directly to the discharge fitting on the AOST.

Ensure there are no leaks in the test tool. The system may not idle down if there are leaks in the lines or fittings.

- Install the VMAC test tool at the AOST outlet with the appropriate orifice.
- Ensure the ball valve is closed.
- Start the system. See "What to Expect at Startup" on page 47 for more information.
- Ensure the system has reached normal operating temperature and is no longer in "Soft Start".
- Observe the pressure gauge on the test tool. The pressure should be approximately 150 psi.
- Open the ball valve on the test tool completely and observe the pressure gauge.



If the system is not able to maintain air pressure at 90 psi when the ball valve is fully opened, the compressor has failed the performance test.

- Close the ball valve slowly to allow the system pressure to rise.
- When the pressure reaches 150 psi (factory default setting), the system will "unload" and air should be heard to escape from the inlet. Systems configured for 2 speed operation will reduce flow to maintain the minimum gpm.

After 1 minute without air use (factory setting), the hydraulic fluid will continue to circulate through the cooler but the compressor will stop turning. The system will continue to monitor the temperature of the hydraulic fluid and will activate the cooling fan as required.

The system will continue to monitor temperature and air pressure and will restart as needed to maintain operating parameters.



VIMAC®

AIR INNOVATED®



Hydraulic Driven Air Compressor Owner's Manual

Identifying Your System

The System ID will be requested any time that parts are ordered, when calling for technical support, or submitting a warranty claim.

The system ID is the preferred method of identifying the system as it serves as a master record of all of the components in the system. The system ID plate is generally found on the top cover of the Hydraulic Driven Air Compressor (Figure 11).

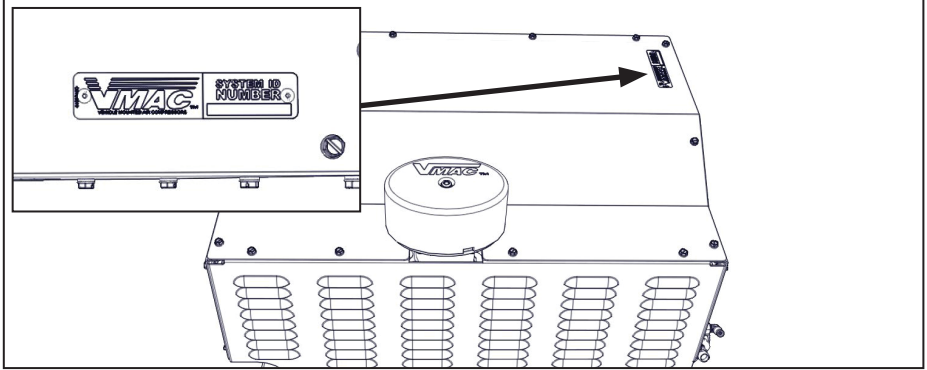

Figure 11 — System ID location

An alternative method of identifying the system is via the compressor serial number which is found on a plate attached to the compressor. This is a less desirable method of identifying the system as it may not link back to the original system if it has been replaced.

System ID breakdown

The system ID provides specific information about the system such as the model, revision, production date and the unique identifier (Figure 12).

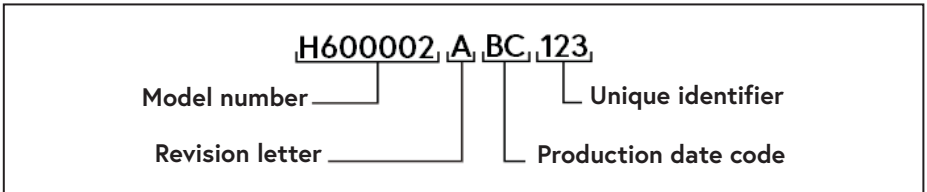

Figure 12 — System ID breakdown

Hydraulic System Variants

H400001: 40 cfm (standard).

H400003: 40 cfm with 24 V fan and black panels.

H400004: 40 cfm (black panels)

H400010: 40 cfm (Knapheide).

H400017: 40 cfm with 24 V fan and white panels.

H400018: 40 cfm (Service Truck International)

H600002: 60 cfm (standard).

H600004: 60 cfm (HHP).

H600008: 60 cfm (black panels).

H600014: 60 cfm (Service Truck International)

VMAC - Vehicle Mounted Air Compressors

VMAC Technical Support: 888-241-2289

VMAC Knowledge Base: kb.vmacair.com

System Components and Specifications

Components

The Hydraulic Driven Air Compressor system consists of the following components:

- Air Oil Separator Tank (AOST).
- Compressor.
- Hoses and tubes.
- PTFE oil scavenge and pressure control tubes.
- Digital display box.
- Liquid to air cooler.
- Hydraulic manifold.
- Air solenoid.
- Control box.
- 24 V to 12 V converter (on 24 V systems only).

AOST

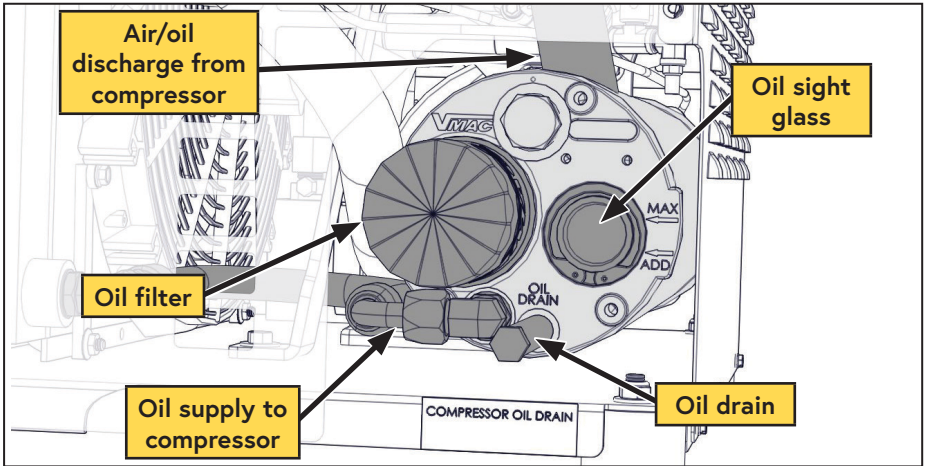

Figure 13 — AOST (front)

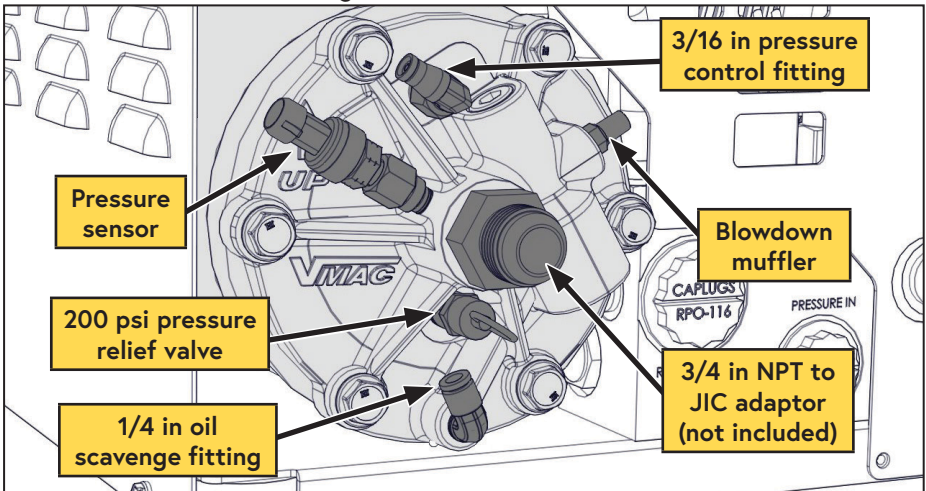

Figure 14 — AOST blowdown cap (back)

Compressor

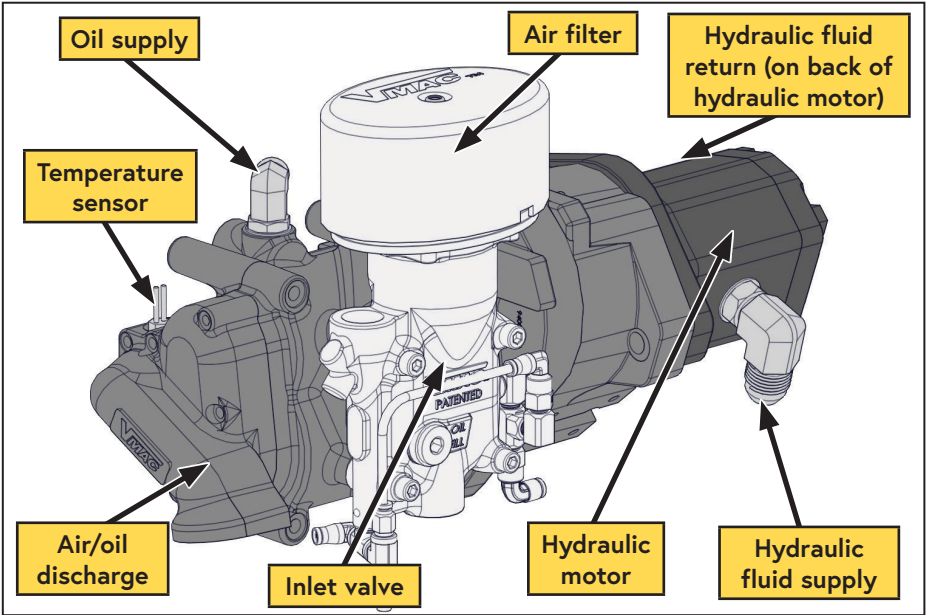

Figure 15 — Compressor assembly

Liquid to Air Cooler

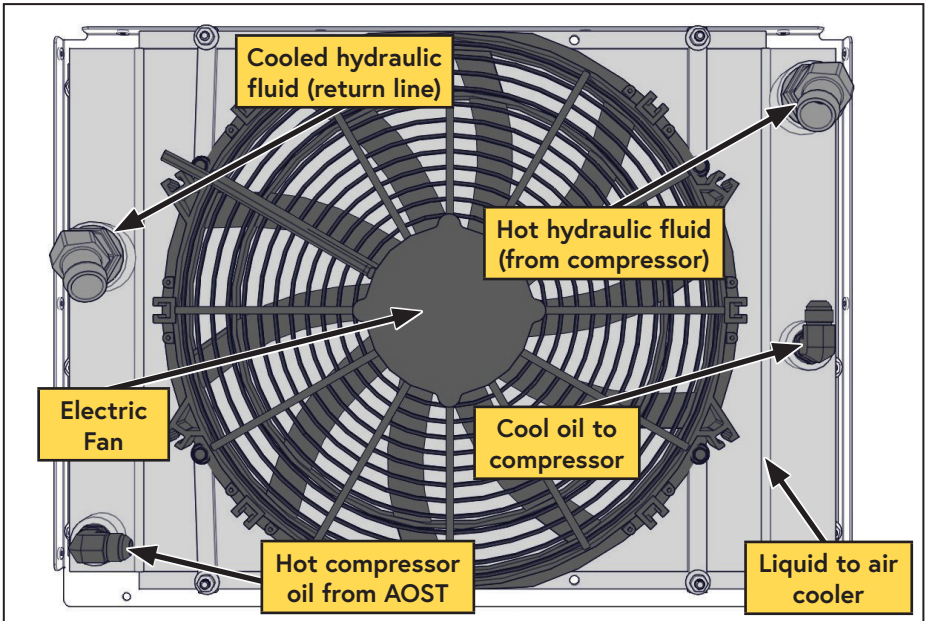

Figure 16 — Compressor oil / hydraulic fluid cooler

Hydraulic Manifold

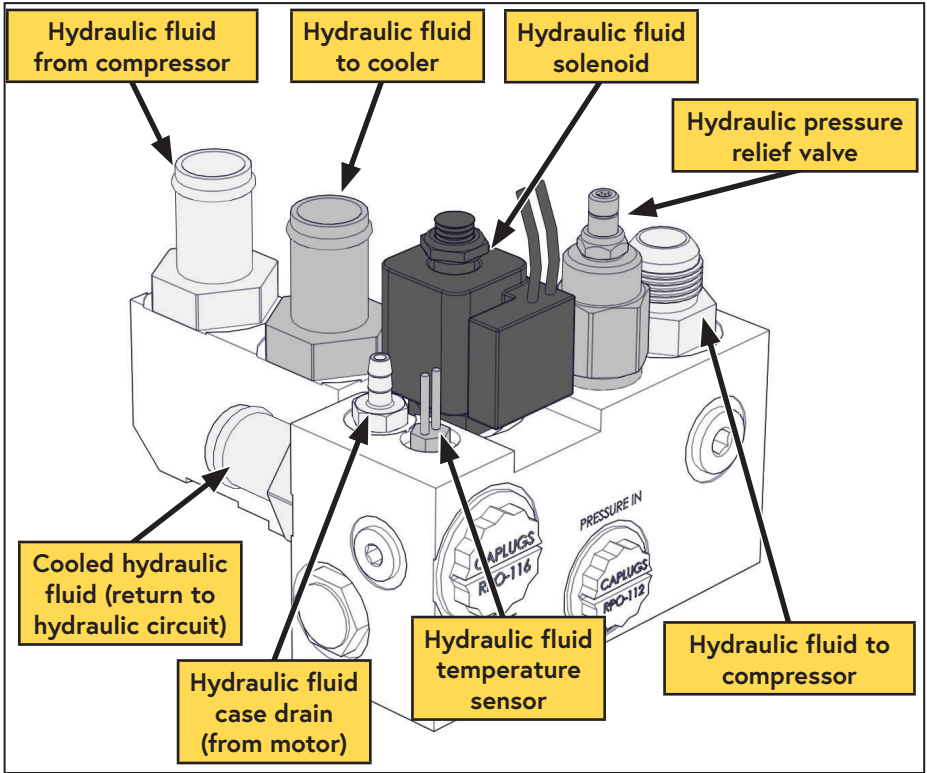

Figure 17 — Hydraulic manifold

Control Box

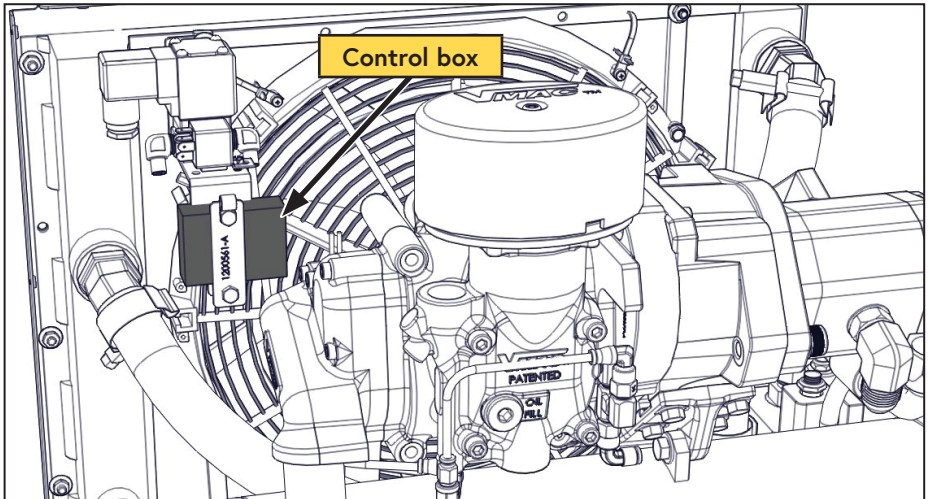

Figure 18 — Control box

Air Solenoid

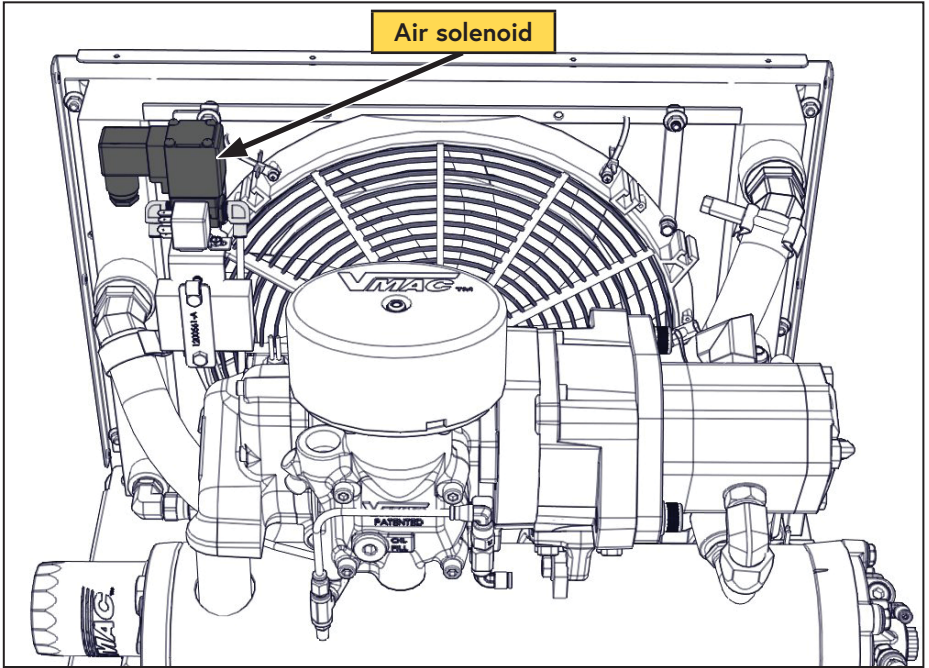

Figure 19 — Air solenoid

24 V Converter (on 24 V systems only).

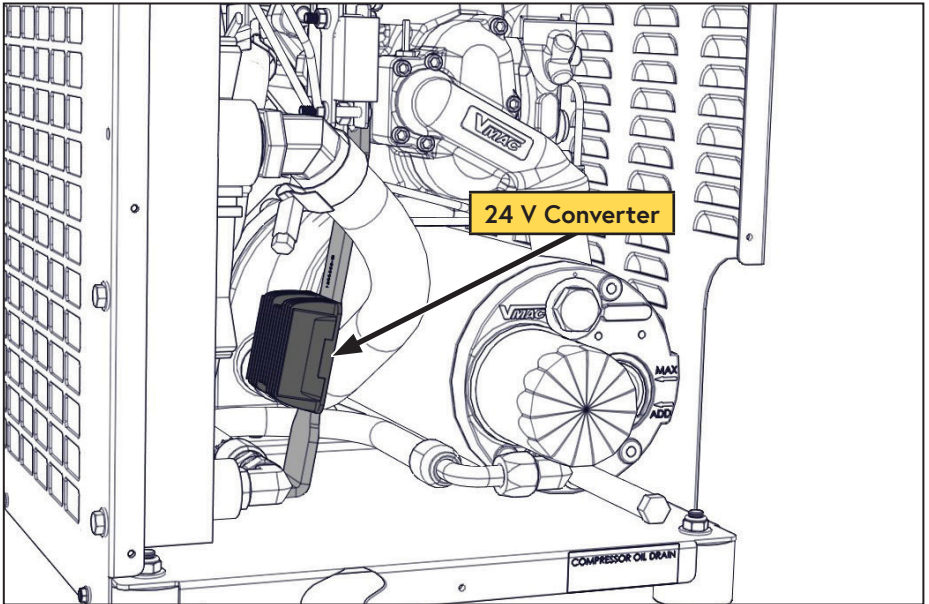

Figure 20 — 24 V converter

Digital Display Box

The display box serves as the operator's control panel and contains the "ON/OFF" button, "READY" and "WARNING" lights, and the display LED which includes information such as compressor hours, service reminder, warning messages, error codes, access to the advanced settings, and diagnostic information.

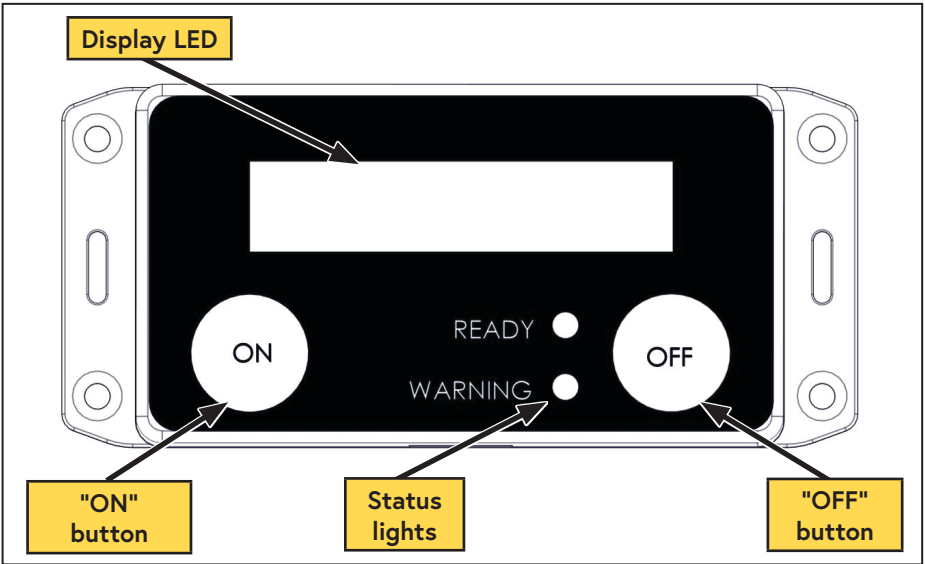

Figure 21 — Display box

Hoses / Tubes

The hoses used in VMAC compressor systems have an AQP inner liner that is compatible with VMAC compressor oil. The PTFE tubes used in VMAC systems are rated for the high temperatures VMAC compressors generate. Use of hoses or tubes other than those supplied or recommended by VMAC may cause compressor damage and may void your warranty. Please contact VMAC for replacement hoses/tubes or for further information.

- Hoses must have an AQP liner.
- Oil scavenge and pressure control tubes must be PTFE.



VMAC Compressor oil will degrade rubber lined hoses, use only hoses with an AQP elastomer type liner. Contact VMAC Technical Support at 1-888-241-2289 for further information.

Specifications

	<p><i>VMAC's Hydraulic Driven Air Compressors are designed to be driven by fixed displacement hydraulic pumps.</i></p> <p><i>Hydraulic circuits using "pressure compensated" variable displacement pumps must have a Closed Centre Manifold installed at the Hydraulic Driven Air Compressor (see "Accessory Products from VMAC" on page 87).</i></p> <p><i>VMAC's Hydraulic Driven Air Compressors are not compatible with "load sensing" variable displacement hydraulic pumps.</i></p>
--	---

Air Compression

Our Hydraulic Driven Air Compressors use a VMAC designed and manufactured flooded lobe, rotary screw compressor. The oil filled compressor housing contains 2 rotors. Compression occurs when air (at normal atmospheric pressure) enters a chamber where it is trapped between meshing rotor lobes. Cooled oil is injected into the rotors during compression to lubricate the rotors and bearings, absorb the heat of compression, and seal the rotor lobes to allow for efficient compression. As the rotors rotate, the meshing lobes compress the volume of the trapped air/oil mixture before sending it down the discharge line to be cooled and separated by the Air Oil Separator Tank (AOST).

Oil Separation

The system uses a proprietary 2 stage air/oil separator. The hot air/oil mixture from the compressor enters the first stage of the AOST and is mechanically separated with baffles. The second stage uses an integral coalescing element to remove the remainder of the oil from the air stream.

The small amount of oil recovered from the coalescing filter is returned directly to the compressor via the 1/4 in PTFE scavenge tube.

Compressor Oil and Hydraulic Fluid Cooling

A liquid-to-air cooler maintains operating temperatures in an optimal performance range which increases system durability and reduces the temperature of the compressed air.

Hot compressor oil is directed from the AOST to VMAC's liquid to air cooler before being returned to the compressor. The liquid to air cooler also cools the hydraulic fluid to ensure the Hydraulic Driven Air Compressor does not add heat to the hydraulic circuit.

Filtration

VMAC rotary screw compressors are designed and machined to exacting standards. Foreign particles entering the compressor can damage components such as rotors, bearings, seals, and the housing, resulting in performance, efficiency loss, and reduced system life.

The system is equipped with a replaceable paper element air filter, a high pressure spin-on oil filter, scavenge screen and a coalescing filter in the back of the AOST.

VMAC - Vehicle Mounted Air Compressors

VMAC Technical Support: 888-241-2289

VMAC Knowledge Base: kb.vmacair.com

Pressure Regulation

Pressure regulation is achieved via a mechanical inlet control valve and an electric air solenoid.

The system pressure is set at the factory to 150 psi. Pressure can be adjusted between 110 psi and 150 psi by using the display box. To reduce the operating pressure, VMAC recommends using an Filter Regulator Lubricator (FRL) (P/N: A700151). Refer to "Accessory Products from VMAC" on page 87.

Safety Features

A 200 psi (1380 kPa) pressure relief valve is installed in the AOST to prevent over pressurization. The AOST is also equipped with an integrated rapid blow down system that automatically discharges pressure from the AOST upon shutdown.

Temperature sensors are installed in the compressor and the hydraulic manifold. In the event that the air/oil, or hydraulic temperature increases above a safe level, the system will deenergise the hydraulic solenoid, stopping the compressor. The red "WARNING" light on the Display Box will illuminate and the error will be logged in the system.

H40 / H60	H60 HHP
<ul style="list-style-type: none">2,800 psi hydraulic pressure relief valve.	<ul style="list-style-type: none">3,300 psi hydraulic pressure relief valve.

Table 10 — Hydraulic pressure relieve valve values

System Operation

(What to Expect at Start Up)

Before Running the Hydraulic Driven Air Compressor:

- Ensure the system is not mounted (or parked) on grades exceeding 15° as this will affect lubrication and air/oil separation (Figure 22).

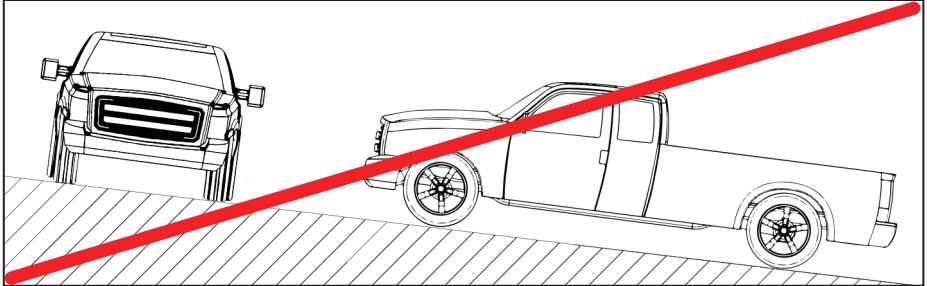

Figure 22 — Do not exceed 15° grade



If installed inside a cabinet or enclosure, open the cover or door completely and secure it in the open position to provide proper ventilation.

Startup Procedure

- If equipped, open the hydraulic shutoff valve.
- Check the compressor oil level at the sight glass in the AOST.
- Check the hydraulic fluid level in the hydraulic system tank.
- Engage the hydraulic system.
- Turn on the power to the Hydraulic Driven Air Compressor.
- Press the "ON" button on the display box to start the Hydraulic Driven Air Compressor.
- Watch the display box for system status information.

What to Expect at Startup



If installed, the VMAC Cold Climate Kit (P/N: A700280) will automatically activate in cold weather.



The Hydraulic Driven Air Compressor will not generate full system pressure (150 psi) until both the hydraulic fluid and compressor oil are at operating temperature.

- 1) The green light on the display box will illuminate.

Cold Weather Startup (Temperature Below 3 °F (-16 °C))

- 2) If the temperature is below -13 °F (-25 °C), the green light on the display box will blink slowly and "HYD OIL TOO COLD" will be shown on the display. The hydraulic fluid must be preheated as the hydraulic fluid is too cold for the VMAC Cold Climate Kit P/N A700280 to be activated.
- 3) If the temperature is between -11 °F (-24 °C) and 3 °F (-16 °C) the green light on the display box will blink slowly and "HYD OIL WARMING, HYD xxxF/xxx°C" will be shown on the display.
 - If the VMAC Cold Climate Kit is installed, it will be enabled automatically to reduce the time it takes to warm the hydraulic fluid.
 - If the system has been configured for 2 speed operation, the engine speed will increase after 10 seconds to reduce the time it takes to warm the hydraulic fluid.
- 4) When the hydraulic fluid reaches 5 °F (-15 °C), "SOFT START xx°C" will be shown on the display, the VMAC Cold Climate Kit will turn off, the engine speed will be reduced, and the startup cycle will proceed normally.

Soft Start (Compressor Below 158 °F (70 °C) / Hydraulic Fluid Below 41 °F (5 °C))



While in "Soft Start", air can be used but the pressure and cfm generated by the system is restricted to reduce the load on the hydraulic system.

The Hydraulic Driven Air Compressor will only build between 40 psi and 120 psi (dependent upon what stage of the warming the system is in) until the hydraulic fluid has reached 41 °F (5 °C) and the compressor oil temperature has reached 158 °F (70 °C).

- 5) Once the system enters "Soft Start", the compressor is activated to warm the compressor oil. During the first stage of "Soft Start" the system is limited to approximately 40 psi.
- 6) When the compressor oil has reached 90 °F (32 °C), the system enters the second stage of "Soft Start", the compressor will "load up" and build air pressure to 120 psi (systems configured for 2 speed operation will increase engine speed to build air pressure faster). The Hydraulic Driven Air Compressor will be limited to 120 psi until the system reaches "normal operating temperature", "120 PSI MAX" will be shown on the display.

Normal Operation

Once the system reaches "normal operating temperature" (compressor temperature: 158 °F (70 °C) / hydraulic fluid: 41 °F (5 °C)), the system will build to full system pressure (150 psi) and maximum cfm (the cfm that the system develops is dependent upon hydraulic fluid gpm, see "Hydraulic Requirements" on page 17).

During normal operation, the Hydraulic Driven Air Compressor monitors various parameters including compressor temperature, hydraulic fluid temperature, and air use.

When no air use is detected, the system will first unload the compressor and then enter "Standby" to minimize fuel consumption, equipment wear, hydraulic and compressor temperature, and noise.

System Unload

Once the system has built to 150 psi, the compressor will "unload". If the engine speed had increased, it will drop to base rpm to "unload" the hydraulic system.



A hissing sound may be heard near the inlet valve as excess air is released to reduce pressure inside the compressor to approximately 40 psi.

If no air use is detected after 2 minutes (pressure in the AOST remains above the restart point (factory default: 120 psi), the system will enter "Standby".

System Standby

Once in "Standby", the hydraulic motor will turn off and "STANDBY xxx PSI" will show on the display. The delay to standby time and restart pressure is adjustable, (see page 54).

As stored air is used and the pressure drops below the configured restart pressure, the sequence of "load up" and "unload" will repeat, (if the system is configured for 2 speed operation, engine speed will increase and drop accordingly). The system may restart occasionally (even without air use) to maintain the correct compressor and hydraulic fluid operating temperatures.



In order for the "Standby" feature to operate efficiently, the use of an air receiver tank is strongly recommended as it will reduce cycling between "load" and "unload" modes.

Shut-down

- 1) When air is no longer required, allow the system to build to full system pressure (150 psi) and unload.
- 2) Stop the Hydraulic Driven Air Compressor via the vehicle's control panel. Any residual pressure in the compressor or AOST will blow-down automatically.
- 3) Disengage the hydraulic system.
- 4) If equipped, close the hydraulic shut-off valve.
- 5) Turn off the power supply to the Hydraulic Driven Air Compressor.
- 6) Drain any stored air.

Cold or Hot Weather Operation



The compressor will not start until the hydraulic fluid temperature reaches 5 °F (-15 °C). Special design considerations are required for systems that will be used in cold climates.

Refer to the installation section for detailed information.

Hydraulic Fluid

Use hydraulic fluid that is correctly rated for the operational temperature range of the equipment.

Cold Weather Operation

When operating in cold temperatures, the following precautions should be observed:

- If the ambient temperature is below 41 °F (5 °C), cover the Hydraulic Driven Air Compressor during transit (if exposed) and preheat the unit by circulating hydraulic fluid through the system before starting the compressor.
- If the ambient temperature is below 5 °F (-15 °C), install the VMAC Cold Climate Kit (P/N: A700280) and circulate the hydraulic fluid through the system.
- Do not allow ice or snow to build up around the air filter and inlet control valve.

Hot Weather Operation

When operating in hot temperatures, the following precautions should be observed:

- If the ambient temperature is above 100 °F (38 °C), reduce the compressor duty cycle.
- Provide additional hydraulic fluid cooling. The VMAC Hydraulic Oil Cooler (P/N: A850001) is able to remove 18,750 BTU/Hr with a 50 °F (10 °C) difference in temperature between the hydraulic fluid and ambient temperature.
- Provide additional ventilation if the compressor is inside a cabinet or enclosure. Cool air results in better performance and higher cfm (see page 14).

Automatic Shutdown

If the compressor or hydraulic fluid gets too hot, the over temperature circuit will disengage the hydraulic system, illuminate the red LED on the display box, and the display box will show a message identifying the problem.

- 1) Turn the compressor "OFF".
- 2) Allow a few minutes for the air system to vent pressure and for the oil to drain back to the tank. Check the compressor oil level through the sight glass on the AOST (the oil level must be checked with the vehicle level). If the oil level is low, add VMAC compressor oil until the correct level is reached (see page 60).
- 3) Check the hydraulic fluid level. If necessary, add hydraulic fluid until the correct level is reached.

If this problem persists, refer to the troubleshooting section in this manual (starting on page 72).

Display Box Messages

The display box presents various context specific messages such as: service reminders, error messages, or the current state (e.g. "SOFT START xxxC").

System Check

The display will show "VMAC — WWW.VMACAIR.COM" and both the red and green LED lights will flash.

The display will then show "SYSTEM CHECK / SYSTEM READY" and the system will go to the "Ready State".

Ready State

The display will scroll through the following messages:

VMAC → PH# 250 740 3200 → HRS: xxxx:xx

The following additional messages may be displayed at this time

500 hour service is due:

"HRS: xxxx:xx 500S"

If the hydraulic fluid temperature is below 5 °F (-15 °C):

"WARM HYD OIL"

Every 100 hrs the system will remind the operator.

"CHECK AIR FILTER"

Initial Startup (see page 47)

During initial startup, the display may show the following messages:

"SOFT START xxxC"

The system has started but the compressor oil is too cold. The compressor is in "unload" mode and will only build to 40 psi.

"HYD OIL TOO COLD"

The hydraulic fluid is below -13 °F (-25 °C), and the system is cautioning the operator to preheat the hydraulic fluid (the system will not start until the hydraulic fluid is above -13 °F (-25 °C)).

"HYD OIL WARMING, HYD xxxF/xxxC"

The hydraulic fluid is between -11 °F (-24 °C) and +5 °F (-15 °C). If installed, the VMAC Cold Climate Kit will turn on to help warm the hydraulic fluid.

The Hydraulic Driven Air Compressor will not start until the hydraulic fluid has warmed to 5 °F (-15 °C).

Normal Operation

The system pressure, compressor oil and hydraulic fluid temperatures can be viewed by pressing the "ON" button while the system is running (use the "ON" button to scroll through the different messages).

xxxPSI/xxxKPA

COMP xxxF/xxxC

HYD xxxF/xxxC

HRS:xxxx:xx

VMAC - Vehicle Mounted Air Compressors

VMAC Technical Support: 888-241-2289

VMAC Knowledge Base: kb.vmacair.com

Standby

The following message will be displayed once the system enters Standby mode.
"STANDBY xxxPSI"

While the system is in standby the hydraulic solenoid is off and the system is monitoring air pressure as well as compressor and hydraulic fluid temperatures. If the air pressure drops below the restart pressure (factory default: 120 psi), or the compressor oil temperature drops below 158 °F (70 °C), the hydraulic solenoid will energize and the system will build to 150 psi.

Error Messages

Refer to "Diagnostics and Troubleshooting" on page 72 for more information.

"OVER TEMP COMP"

The compressor is too hot.

"OVER TEMP HYD"

The hydraulic fluid is too hot.

"COMP PROBE SHORT"

The compressor temperature probe has failed in a shorted condition.

"COMP PROBE OPEN"

The compressor temperature probe has failed in an open condition.

"HYD PROBE SHORT"

The hydraulic fluid temperature probe has failed in a shorted condition.

"HYD PROBE OPEN"

The hydraulic fluid temperature probe has failed in an open condition.

"BATTERY LOW"

The control box has sensed a low supply voltage.

"PRESSURE SENSOR?"

The pressure sensor has failed or is disconnected.

"CONNECTION ERR"

There is a connection problem between the control box in the Hydraulic Driven Air Compressor and the display box.

System Adjustments (Diagnostics Mode)

Diagnostics Mode provides access to various features such as error logs, user adjustable settings, service logs, and "Limp Mode".

Entering DIAGNOSTICS mode

With the system off:

- 1) Push and hold the "OFF" button for 5 seconds.

The display will show "DIAGNOSTICS".

- 2) Release the "OFF" button.

The system will slowly scroll through the menu headings.

Entering a submenu

When the desired submenu is displayed:

- 1) Press and hold the "ON" button.

Once the system has entered the desired submenu:

- 2) Release the "ON" button.

Scrolling

While in a submenu, scroll through the data and variables using the "ON" and "OFF" buttons.

Exiting a submenu

Once changes have been made, press and hold both the "ON" and "OFF" buttons at the same time. The system will return to the main diagnostics menu.

Exiting DIAGNOSTICS mode

While DIAGNOSTICS is displayed, press and hold both the "ON" and "OFF" buttons at the same time or power down the Hydraulic Driven Air Compressor.

Submenus

The following submenu items are accessed via the **DIAGNOSTICS** menu:

ERROR LOG (Figure 23)

Record of the last 10 system errors.

This information can be recorded on the VMAC troubleshooting form on page 90 and emailed or faxed to VMAC Technical Support to assist in troubleshooting issues. Scroll through the errors using the "ON" and "OFF" buttons.

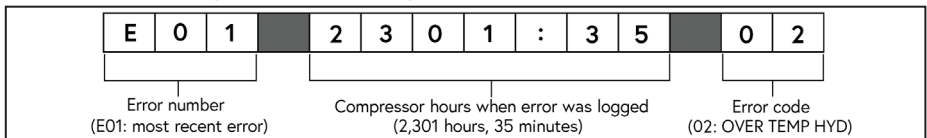

Figure 23 — Error log display

SERVICE LOG

Clears the service message and records the system hours when the last 10 system service reminders were cleared.

If the display has been showing a reminder for the 500 hour service, once the service has been completed, enter this section and clear the message.

VMAC - Vehicle Mounted Air Compressors

VMAC Technical Support: 888-241-2289

VMAC Knowledge Base: kb.vmacair.com

500HR CLEAR?

Press and hold the "ON" button for 5 seconds to clear the message. Scroll through each recorded service using the "ON" and "OFF" buttons.

AIR TEMP. SENSOR

This setting provides a temporary override ("limp mode") of the air temperature sensor at the compressor discharge. See "Limp Mode" on page 55 for more information.

HYD TEMP. SENSOR

This setting provides a temporary override ("limp mode") of the hydraulic temperature sensor at the hydraulic manifold. See "Limp Mode" on page 55 for more information.

SYSTEM PRESSURE

Used to adjust the maximum system pressure. The configurable range is: 110 psi to 150 psi (factory default is 150 psi).



For optimum performance, leave the system set at 150 psi and use a regulator to reduce downstream air pressure.

Press and hold the "ON" button for 2 seconds, the display will show: "ADJ OFF PRES xxx" ("xxx" represents the current pressure setting in psi).

The system will scroll through the range of settings. When the desired setting is displayed, press the "ON" button to make the selection. Press and hold the "ON" and "OFF" buttons at the same time to save the setting.

RESTART PRESSURE

Used to adjust the system restart pressure. The configurable range is: 80 psi to 120 psi. This setting is limited to 30 psi (or greater) below the "UNLOAD PRESSURE" (factory default is 120 psi).

Press and hold the "ON" button for 2 seconds, the display will show: "ADJ ON PRES xxx" ("xxx" represents the current pressure setting in psi).

The system will scroll through the range of settings. When the desired setting is displayed, press the "ON" button to make the selection. Press and hold the "ON" and "OFF" buttons at the same time to save the setting.

DELAY TO STANDBY

Used to adjust the time delay before the system goes into "STANDBY". The configurable settings are 30 seconds, 45 seconds, 1 minute, 2 minutes, 5 minutes, 10 minutes, 15 minutes, 30 minutes and Never (factory default is 2 minutes).

The system will scroll through the range of settings. When the desired setting is displayed, press the "ON" button to make the selection. Press and hold the "ON" and "OFF" buttons at the same time to save the setting.

COLD START LOG

This is a record of the last 10 cold start temperatures (below 32 °F (0 °C)).

This information can be recorded on the VMAC troubleshooting form on page 90 and faxed to VMAC to assist in troubleshooting any issues.

Scroll through the cold start log using the "ON" and "OFF" buttons.

Limp Mode



Limp mode should only be used in an emergency to complete a job when servicing the unit is not immediately possible.

Running the system without an air or hydraulic temperature sensor may result in failure of the unit and/or damage to the hydraulic system, and is not recommended.

While in "limp mode", the display box will show "NO TEMP. PROBE?" and the red LED will illuminate, then "CHECK OIL", and the green LED will illuminate, followed by "xxxx:xx" (system hours).

While in "limp mode", the display box will toggle between the messages approx every second. During this time, the hydraulic solenoid will be energized for 1 minute to allow the system to build pressure, then deenergized for 1 minute.

When the system is turned off, "Limp mode" will be disabled and the system will operate normally. The system will need to be placed back into "Limp Mode" any time the unit is turned off until the issue is corrected.

"Limp mode" is accessed via the "DIAGNOSTICS" menu.

AIR TEMP. SENSOR

To temporarily disable the air temperature sensor (located beside the compressor):

- 1) Press and hold the "ON" button for 2 seconds.

The display will show: "NO AIR TEMP PRB?"

- 2) Press and hold the "ON" button for 5 seconds.

The display will show: "TEMP PROBE DIS" indicating that the air temperature sensor at the compressor discharge has been disabled.

To enable the air temperature probe:

- 1) Press and hold the "OFF" button for 5 seconds.

The display will show: "TEMP PROBE EN" indicating that air temperature sensor at the compressor discharge has been enabled.

HYD TEMP. SENSOR

To temporarily disable the hydraulic temperature sensor (located in the manifold).

- 1) Press and hold the "ON" button for 2 seconds.

The display will show: "NO HYD TEMP PRB?"

- 2) Press and hold the "ON" button for 5 seconds.

The display will show: "TEMP PROBE DIS" indicating that the hydraulic temperature sensor in the manifold has been disabled.

To enable the hydraulic temperature probe:

- 1) Press and hold the "OFF" button for 5 seconds.

The display will show: "TEMP PROBE EN" indicating that the hydraulic temperature sensor in the manifold has been enabled.

Maintenance Schedule and General Maintenance Information

Illustrated Parts Lists (IPL)

In addition to this manual, the illustrated parts list is an invaluable resource when inspecting, diagnosing or repairing the system. The IPL is available free of charge from VMAC. The part number portion of the System ID will be needed to locate the correct IPL. See "Identifying Your System" on page 39 for the System ID location.



Torque Specifications

All fasteners must be torqued to specifications. Use manufacturers' torque values for OEM fasteners.

The torque values supplied in Table 11 are intended for VMAC supplied components, or for use as a guide in the absence of a torque value provided by an OEM.



Apply Loctite 242 (blue) to all fasteners (except nylon lock nuts) unless otherwise stated.

Torque values are with Loctite applied unless otherwise specified.

Standard Grade 8 National Coarse Thread								
Size (in)	1/4	5/16	3/8	7/16	1/2	9/16	5/8	3/4
Foot pounds (ft•lb)	9	18	35	55	80	110	170	280
Newton meter (N•m)	12	24	47	74	108	149	230	379

Standard Grade 8 National Fine Thread					
Size (in)	3/8	7/16	1/2	5/8	3/4
Foot pounds (ft•lb)	40	60	90	180	320
Newton meter (N•m)	54	81	122	244	434

Metric Class 10.9						
Size (mm)	M6	M8	M10	M12	M14	M16
Foot pounds (ft•lb)	4.5	19	41	69	104	174
Newton meter (N•m)	6	25	55	93	141	236

Table 11 — Torque Table

Routine Maintenance



The Hydraulic Driven Air Compressor must be run a minimum of once every 30 days for at least 30 minutes to prevent impact damage and premature bearing failure in the compressor due to vibration. Regularly running the system will also help to vaporize and exhaust any water that has condensed and accumulated in the AOST.

In order to maintain the VMAC warranty, VMAC's maintenance schedule must be followed. Only genuine VMAC parts can be used to maintain the system.

With proper maintenance, the likelihood of premature failure or component replacement can be drastically reduced.

The most critical aspect of maintenance is proper air filtration, clean oil, and regular use. If any particles enter the compressor, they can score the rotors and contaminate the roller bearings in the compressor. Any contamination will cause rapid and severe damage to components.



In order to maintain the warranty on the Hydraulic Driven Air Compressor, use only genuine VMAC parts to service the system.

Maintenance Schedule

The following maintenance schedule must be observed to maintain both the "Standard" and "Lifetime" VMAC warranties and to assure proper performance and long service life of the system. In the event of a warranty claim, VMAC may request service records.

The hours indicated are those displayed on the Control Box. Service should be performed at the lesser of the two intervals (whichever occurs first).

To order service kits, see the ordering information on page 3.

Daily	
<ul style="list-style-type: none"> • Check compressor oil level. • Check system for leaks. 	<ul style="list-style-type: none"> • Check pressure relief valve condition.
Every 500 hours or 1 year <i>(whichever occurs first)</i>	
<ul style="list-style-type: none"> • Change compressor air filter. • Change compressor oil. • Change compressor oil filter. 	<ul style="list-style-type: none"> • Change pressure relief valve. • Change coalescing filter element. • Inspect blowdown muffler.

Service Kit Contents

500 Hour / 1 Year Service Kit P/N: A700156		
QTY	Part #	Description
1	3600037	Air filter
1	9200039	Oil filter
1	A700094	VMAC High performance oil (4 L)
1	A700152	Coalescing assembly
1	3600064	AOST Tank seal
1	3600090	Thimble screen
1	5840069	SPRING, COMPRESSION, FL 1.5",OD .54
1	5830066	O-RING, VITON, 4 3/4 ID X 1/8
1	4400631	Next service due decal

Heavy Duty Air Filter Replacement Cartridge for A700136 and A700138 <i>(optional equipment, not included in P/N: A700156)</i>		
QTY	Part #	Description
1	9500061	Air filter (heavy duty air filter)

Table 12 — Service kit contents

Maintenance and Repair Safety



It is impossible to warn of all the possible hazards that may result from operating, servicing, or repairing this system.

Wear all appropriate Personal Protective Equipment and follow all industry standard safety practices.



Prior to performing any service, ensure the vehicle transmission is in "PARK" with the parking brake applied and the wheels chocked (if applicable).



Confirm that the system is depressurized and has cooled prior to performing any service work.



Never use flammable solvents to clean any components. If a flammable solvent has been used, rinse the component thoroughly with water and dry it before reinstalling it to prevent the possibility of explosion.



Use only genuine VMAC parts to maintain the system.

Genuine VMAC parts are designed to work with the high pressure and heat generated by the compressor. Substituting genuine VMAC parts may void the warranty and could cause equipment damage, injury, or death.



This information is intended for people with mechanical trade certification who have the tools and equipment to properly and safely perform the service or repair. Do not attempt to service or repair this system without the appropriate mechanical training, knowledge and experience.

Follow all safety precautions and industry standard "best practices".

Safety Check List

- Open the ball valve or connect an air tool to the system to ensure all the stored air is released.
- Gently pull up on the ring on the pressure relief valve to confirm the system is depressurized.



Do not use the pressure relief valve as a means of depressurizing the compressor system. Doing so will prematurely wear the internal spring or the seat, preventing the valve from maintaining normal system pressure.

Regular Inspection Instructions



*Read the "Maintenance and Repair Safety" section prior to performing any work on the system (beginning on page 59).
Wear appropriate Personal Protective Equipment and follow all industry standard safety practices.*



The VMAC supplied and approved compressor oil must be used in this system. Failure to use this special oil will result in damage to the compressor and will void warranty.



Do not overfill the system. Overfilling the system with oil can flood the sight glass window and make the system appear empty.

Inspecting and Adding Compressor Oil

- Ensure the unit is level and that the compressor system is depressurized and cool to the touch.
- Check the oil level in the sight glass and ensure that it is between the "MAX" arrow and the "ADD" arrow.

If the level is below the "ADD" mark, perform the following steps:

- Remove the fill cap.
- Using a funnel, pour oil into the fill fitting until the oil level in the sight glass reaches the "MAX" arrow.



A 45° #12 ORB fitting can be used to extend the fill port and ease oil filling.

- Replace the fill cap and tighten securely.

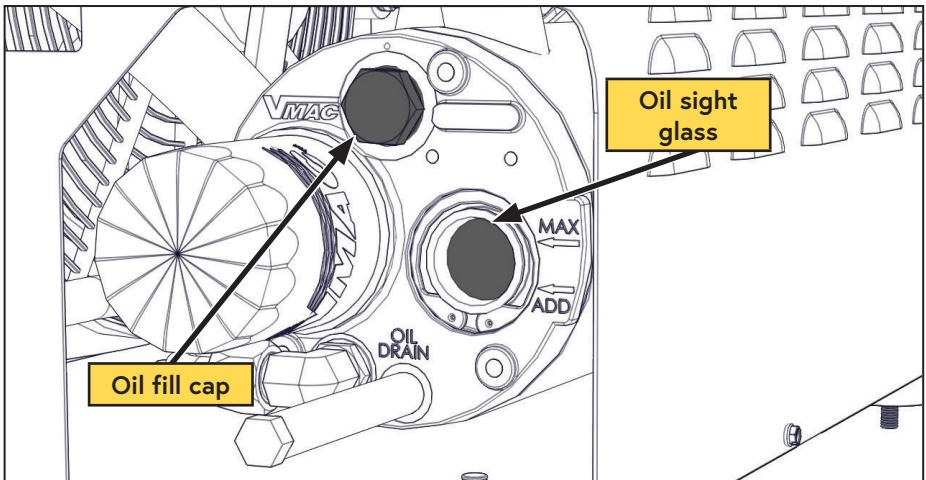

Figure 24 — Inspecting the oil

Inspecting and Replacing the Blowdown Muffler



*Read the "Maintenance and Repair Safety" section prior to performing any work on the system (beginning on page 59).
Wear appropriate Personal Protective Equipment and follow all industry standard safety practices.*

Visually inspect the blowdown muffler for evidence of corrosion or loss of functionality. Ensure the muffler allows the system to depressurize. To test the blowdown system and muffler:

- Turn the system on and allow it reach full system pressure (factory setting 150 psi).
- Turn off the system.
- Listen for the pressurized air to blowdown through the muffler on the AOST. Blowdown should be completed in approximately 20 seconds.
- If the muffler is showing signs of blockage, contact a local VMAC dealer for a replacement.

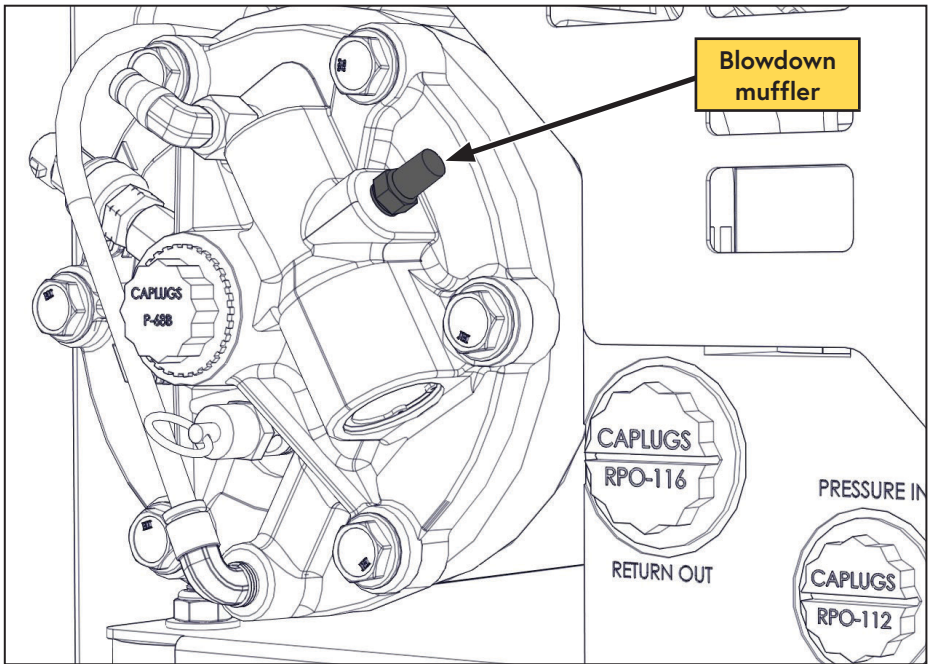

Figure 25 — Blowdown muffler

Inspecting and Replacing the Pressure Relief Valve



**Read the "Maintenance and Repair Safety" section prior to performing any work on the system (beginning on page 59).
Wear appropriate Personal Protective Equipment and follow all industry standard safety practices.**



Do not use the pressure relief valve as a means of releasing pressure from the system. Doing so will prematurely wear the internal spring or the seat, preventing the valve from maintaining normal system pressure.

The Pressure Relief Valve is a regular service item, and must be replaced every 500 hours or 1 year, whichever interval occurs first.

- Visually inspect the valve and ensure it is not corroded and that the vent holes are not plugged.
- Turn the system on and allow it reach full system pressure (factory setting 150 psi).
- Ensure that air does not leak out of the valve. Air leaking from the pressure relief valve when system pressure is at or below 150 psi indicates that the spring or seat in the valve is worn and the valve must be replaced.
- If the pressure relief valve is showing loss of functionality, contact a local VMAC dealer for a replacement.

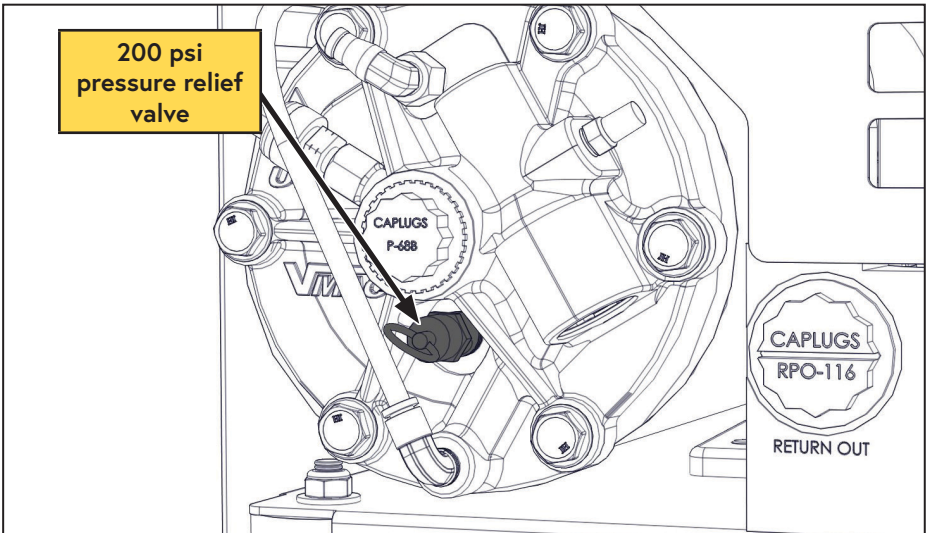

Figure 26 — Pressure relief valve

Replacing the Air Filter



*Read the "Maintenance and Repair Safety" section prior to performing any work on the system (beginning on page 59).
Wear appropriate Personal Protective Equipment and follow all industry standard safety practices.*



To avoid any possibility of contamination, ensure the air inlet is covered with masking tape or a clean cloth whenever the air filter cover is removed.



Do not attempt to clean the filter element, or use compressed air to perform any tasks around the compressor until the filter and cover are replaced.

- Clean any loose debris from around the compressor and the air filter cover to prevent any contamination from entering the system.
- Remove the filter cover retaining nut, filter cover and the filter element. On some installations, it may be necessary to remove the filter assembly from the filter bracket to access the filter cover nut and remove the cover.
- Immediately cover the air inlet opening with masking tape or a clean cloth to prevent any contamination from entering the system.
- Clean the inside of the filter cover with a clean, dry cloth.
- Remove the cloth or masking tape from the air inlet and install the new air filter element.
- Ensure the filter element fits over the "step" on the filter plate.

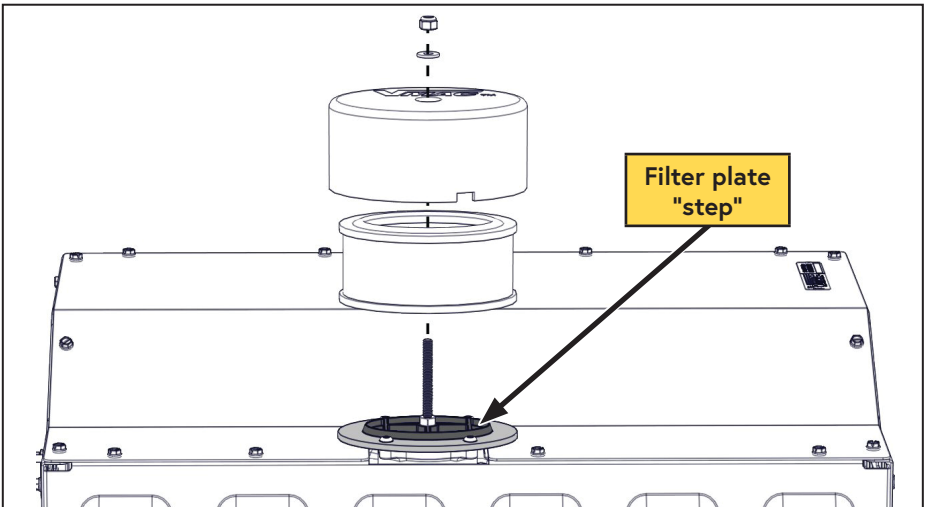

Figure 27 — Install air filter element

- Replace the air filter cover and secure it with the cover nut. Do not over tighten the nut.
- If removed for service, reinstall the filter onto the filter bracket.

VMAC - Vehicle Mounted Air Compressors

VMAC Technical Support: 888-241-2289

VMAC Knowledge Base: kb.vmacair.com

General Service Information



Read the "Maintenance and Repair Safety" section prior to performing any work on the system (beginning on page 59).

Wear appropriate Personal Protective Equipment and follow all industry standard safety practices.

- If the system is cold, operate the compressor system for a few minutes to bring the compressor oil to operating temperature. Warming the system will allow the oil to flow better and will also help to suspend contaminants in the oil allowing them to be removed from the system with the old oil.
- Shut the compressor down.
- Ensure the system is fully depressurized prior to beginning any service work.
- Check the old oil for any evidence of metal filings or contamination. If any metal filings are found, flush the hoses and the ASP using the VMAC flushing kit (P/N: A700214).

PTFE Tubing, Loom, and Push-To-Connect Fittings

- PTFE tubing should only be cut using proper tubing cutters. Side cutters, utility knives, etc. will deform the tube, preventing a proper seal (or leave sharp edges which cut the internal O-ring).
- When applying loom to the PTFE tube, leave approximately 1 in between the loom and the fitting.
- Ensure the tube is clean, cut at 90° and that there are not sharp edges.
- Lubricate the tube and, with the collet pushed into the fitting, firmly push the tube into the fitting until the tube is fully seated.
- Slide the collet out, away from the body of the fitting to lock the tubing in place.
- Ensure the tube does not have any "play" to prevent the O-ring from wearing.

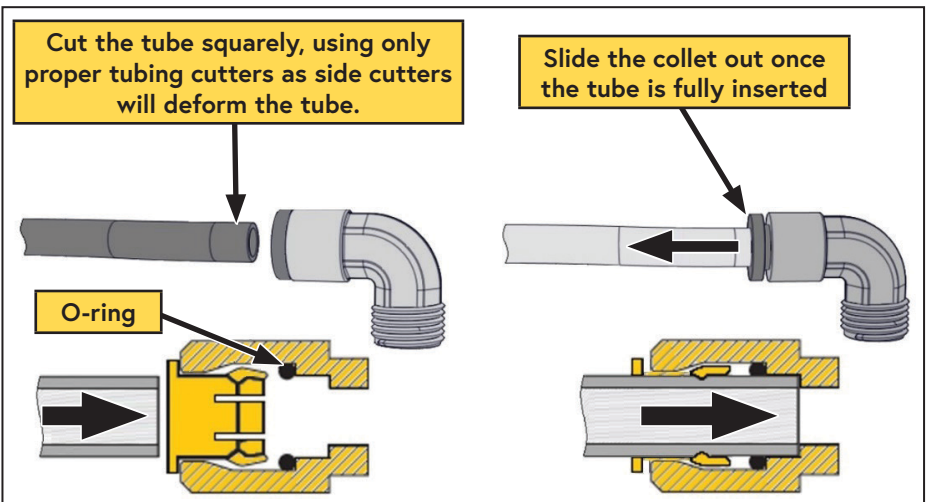

Figure 28 — Push-to-connect fittings

500 Hour / 1 Year Service



*Read the "Maintenance and Repair Safety" section prior to performing any work on the system (beginning on page 59).
Wear appropriate Personal Protective Equipment and follow all industry standard safety practices.*



Do not use compressed air or perform any other tasks around the air filter and cover until both are replaced. Never clean the filter element with compressed air as this may allow contaminants to enter the compressor system. Always replace the air filter element during this service.



Do not overfill the system. Overfilling the system with oil can flood the sight glass window and make the system appear empty.

- Apply thread sealant and replace the pressure relief valve (page 62).
- Replace the air filter (page 63).
- Clean the area around the AOST and the oil filter to prevent contamination.
- Slide a thin drip tray or absorbent material under the filter to collect oil spills.
- Remove the oil drain plug and drain the oil into a container with a capacity of at least 6 L (1.6 USG) (Figure 29).

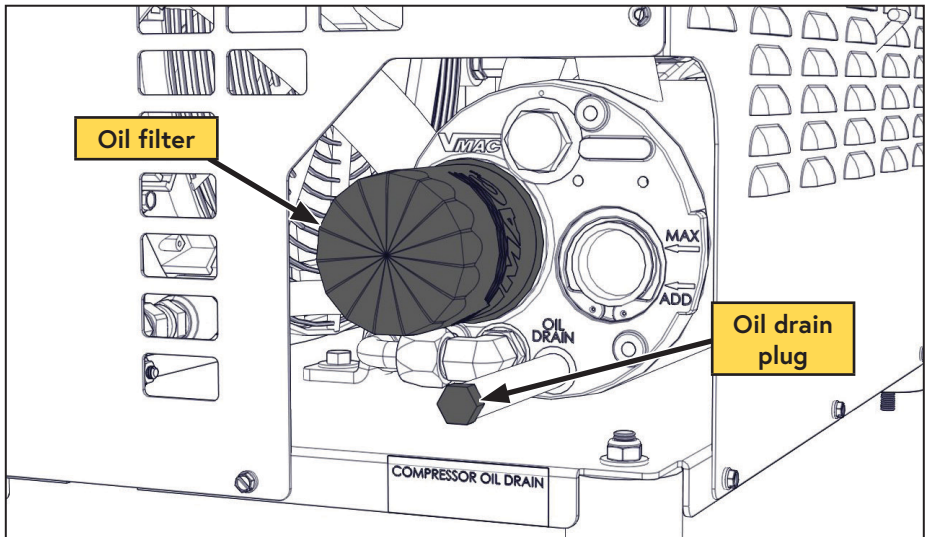

Figure 29 — Compressor oil filter

- Inspect the Viton® O-ring on the oil drain plug for damage, hardness or defects and replace if necessary.
- Install and tighten the oil drain plug.
- Remove the oil filter (Figure 29).

VMAC - Vehicle Mounted Air Compressors

VMAC Technical Support: 888-241-2289

VMAC Knowledge Base: kb.vmacair.com

- Ensure the threaded nipple did not unscrew with the oil filter.
- *If the nipple came out with the oil filter, remove it from the filter, being careful to avoid damaging the threads.
- *To reinstall the nipple, thoroughly clean the threads and apply Loctite 242 (blue) to the end with the short threads and replace it in the AOST (Figure 30).
- Clean the gasket sealing surface on the front of the AOST and inspect it for damage. The surface must be free of old gasket material and smooth to ensure a good seal (Figure 30).

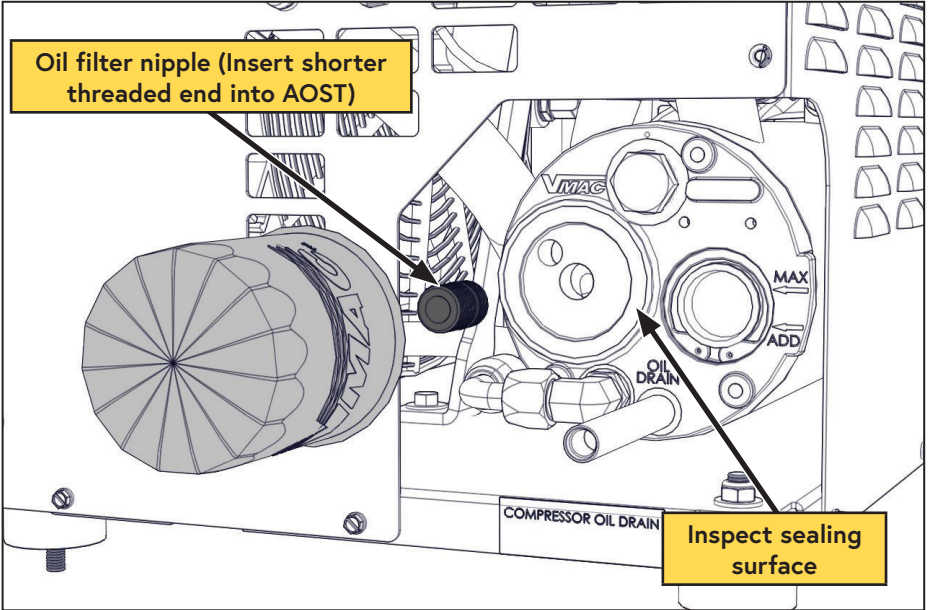



Figure 30 — Compressor oil filter

- Apply a thin coat of compressor oil to the rubber gasket on the oil filter.
- Spin the filter onto the threaded nipple until the gasket contacts the sealing surface on the tank, then tighten the filter an additional 3/4 to 1 turn to seat the gasket.
- Clean the blowdown cap at the rear of the AOST to prevent contamination.
- Remove the PTFE scavenge, and system pressure tubes from the blowdown cap (see page 64) and the air outlet hose. Carefully move the scavenge and system pressure tubes out of the way, ensuring that they do not twist or kink. Cap the air outlet and PTFE fittings to prevent contamination.

 ***The coalescing separator element is spring-loaded against the blowdown cap; to prevent damage to the AOST, remove all of the bolts completely while holding the blowdown cap firmly in place.***

- Remove the bolts retaining the blowdown cap. Unscrew the bolts evenly to avoid damaging the blowdown cap as the coalescing element is spring-loaded against the inside of the end cap.

- Remove the blowdown cap.
- Remove the Viton O-ring, coalescing element and wave spring from the AOST (Figure 31).

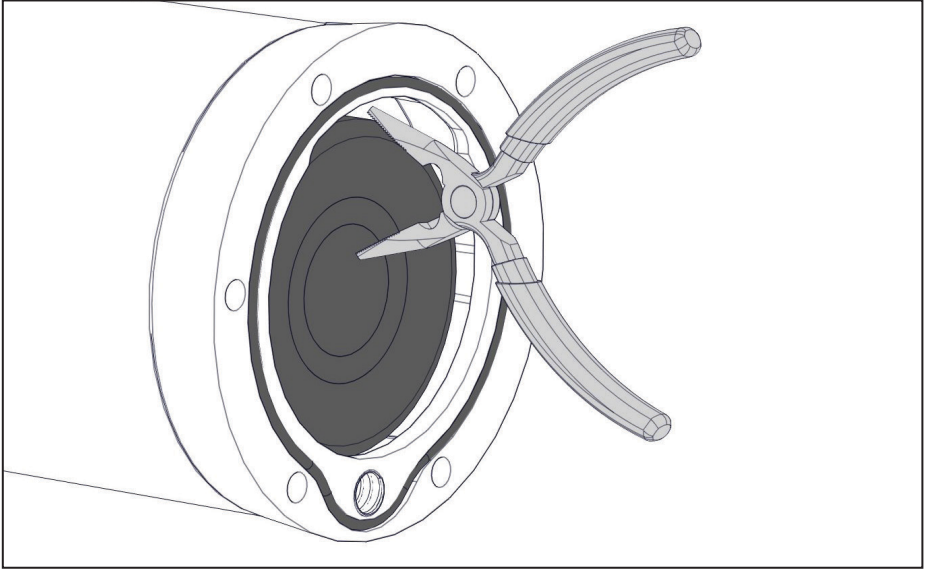

Figure 31 — Replacing the Coalescing filter spring

- Remove the small spring and scavenge screen. The screen can be removed by carefully pushing it out of the oil scavenge hole from the inside of the AOST (Figure 32).

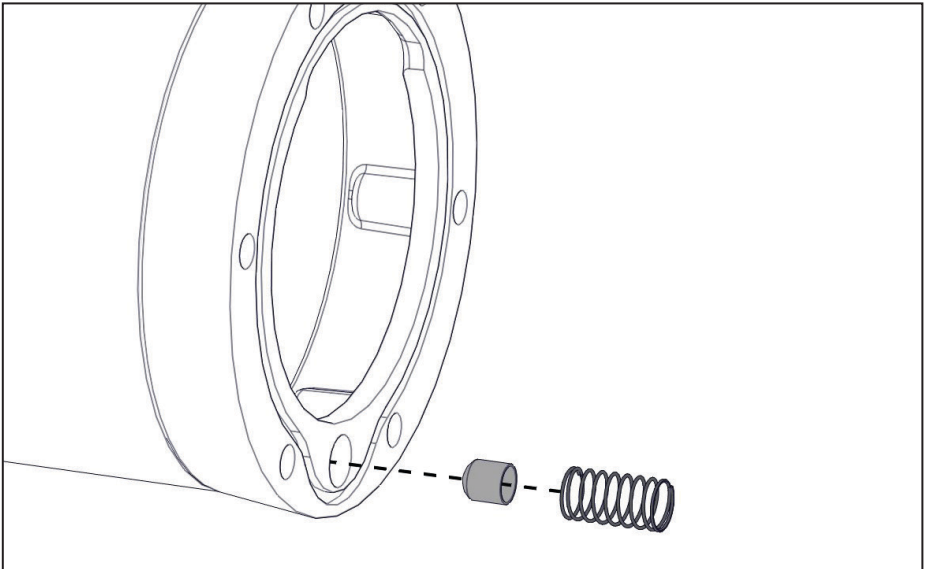

Figure 32 — Remove small spring and scavenge screen

- Wipe out the inside of the AOST.
- Install the new thimble screen and spring (Figure 33).

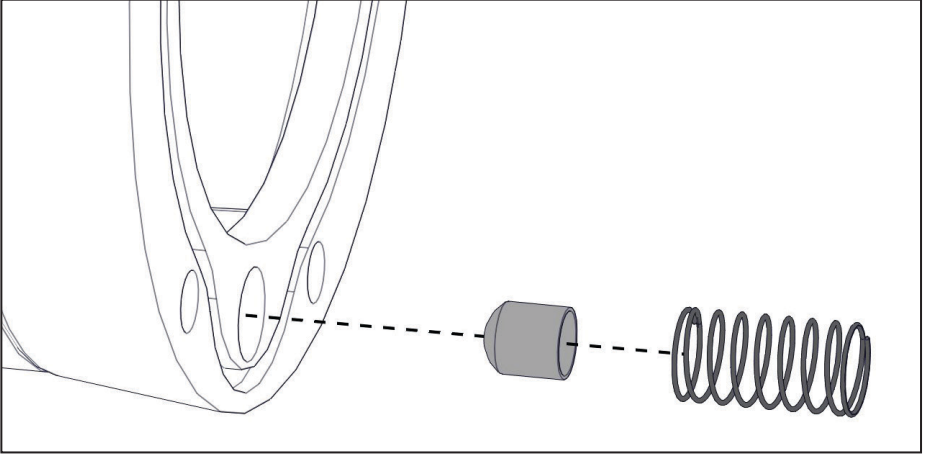

Figure 33 — Install scavenge screen and spring

- Install the wave spring onto the coalescing element (Figure 34).

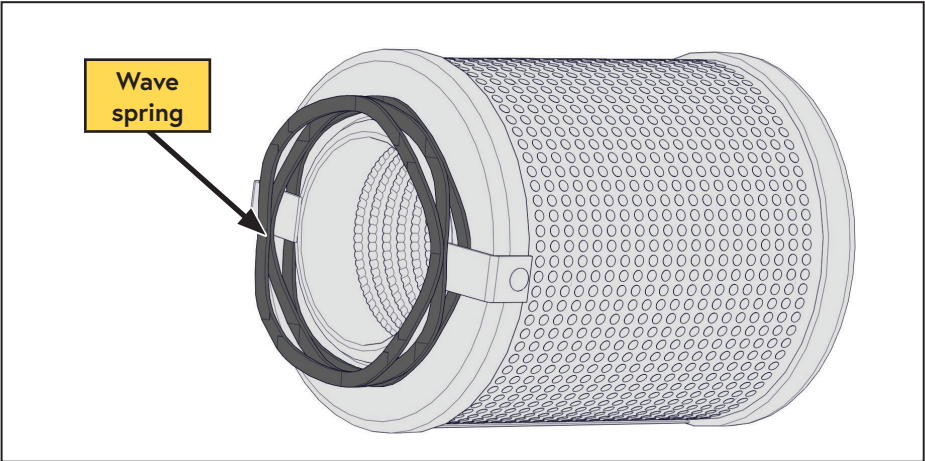



Figure 34 — Install wave spring

 ***In addition to keeping the coalescing filter properly seated, the wave spring also prevents electrostatic buildup by grounding the coalescing filter. Failure to install the wave spring may cause an electric arc which could result in an explosion, tank rupture or fire.***

- Install the coalescing element into the AOST (Figure 35).

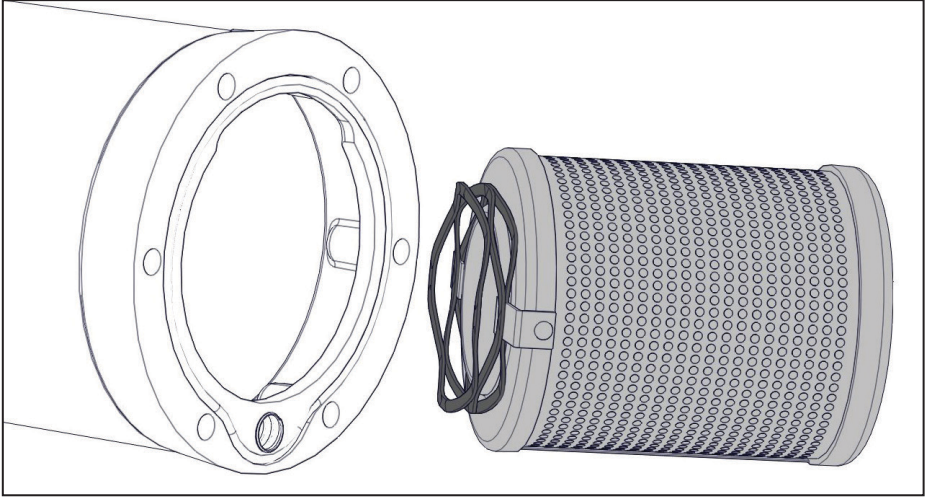

Figure 35 — Install wave spring

- Install the Blowdown cap seal in the blowdown cap (Figure 36).

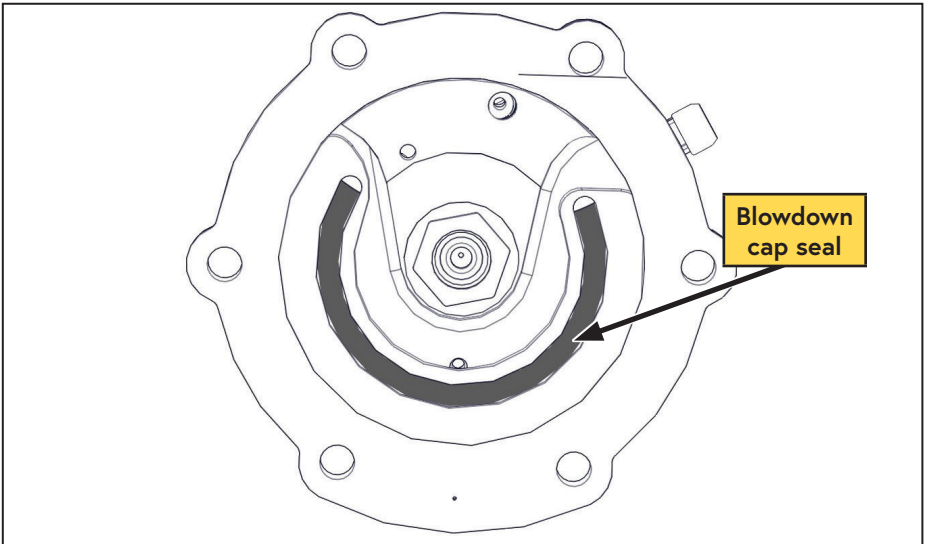

Figure 36 — Rear cap seal

- Install the blowdown cap Viton O-ring in the AOST (Figure 37).

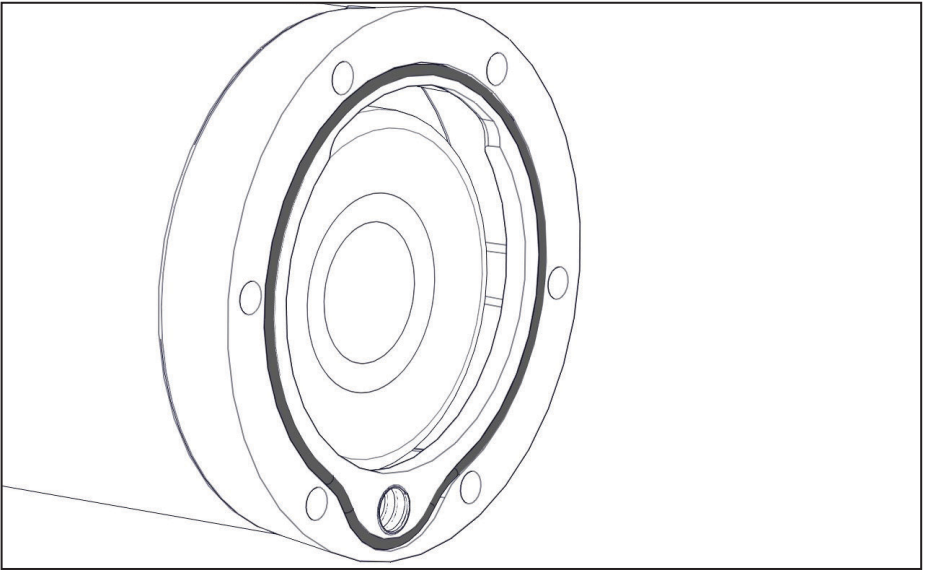

Figure 37 — Blowdown cap O-ring

- Reinstall the blowdown cap onto the AOST.
- Install the PTFE scavenge and pressure control tubes (see page 64) and the air outlet hose onto the blowdown cap.
- Remove the Oil fill cap (Figure 38).

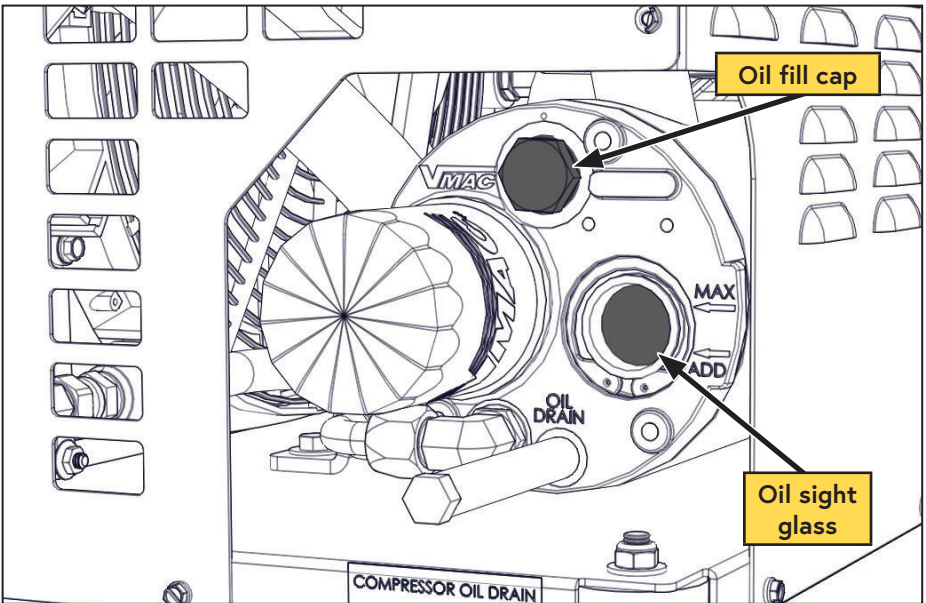

Figure 38 — Oil fill

- Using a funnel, pour oil into the fill fitting until the oil level in the sight glass reaches the "MAX" arrow. The air compressor system holds approximately 1 USG (4 L) of oil.



A 45° #12 JIC to ORB fitting can be used to extend the fill port and ease oil filling.

- Check the oil level at the sight glass on the front of the AOST. Continue adding oil until the level is correct.
- Replace the fill cap and tighten securely.
- Start the system and check for oil leaks.
- Allow the system to build to full system pressure (factory setting 150 psi).
- Turn the system "OFF".
- Once the system has sat for 5 minutes, check the oil level through the sight glass and add oil as necessary.
- Verify there are no oil leaks.

Clearing Service Reminders

For systems that show a message "HRSxxx500HR SVC" on the control box*:

- Press and hold the "OFF" button for approximately 5 seconds until "DIAGNOSTICS" appears on the display.
- Release the "OFF" button. The system will start scrolling through menus.

When the "SERVICE LOG" is displayed:

- Press and hold the "ON" button.

Once the system shows "500HR CLEAR?":

- Push and hold the "ON" button for approximately 5 seconds until "CLEAR OK" appears in the display.



The Display Box will show a reminder to "CHECK AIR FILTER" every 100 hours of operation. This is a time based message that will automatically disappear after 6 hours of operation.

Diagnostics and Troubleshooting



Read the "Maintenance and Repair Safety" section prior to performing any work on the system (beginning on page 59). Wear appropriate Personal Protective Equipment and follow all industry standard safety practices.



For the following tests, isolate the AOST from all downstream (customer supplied) equipment.



If the Hydraulic Driven Air Compressor system is still within the warranty period, see the warranty claim process on page 9 prior to commencing with any diagnostics or repairs.

Problem diagnosis should follow sound, recognized practices. Quick and accurate diagnosis of problems will involve the following:

- Follow industry standard safety practices.
- Accurately identify the problem by operating the system (provided it is safe to do so).
- Determining the possible causes for the problem by understanding how the system operates.
- Isolating the potential causes by accurate testing using the correct and recognized procedures.
- Performing proper repairs using the correct procedures and the recommended replacement parts.
- Performing proper post repair testing to ensure that the repairs were effective.
- Electrical testing should be performed according to the processes described in the troubleshooting charts and in conjunction with any documentation provided by VMAC.
- Additional troubleshooting and specific test procedures can be found on VMAC's Knowledge Base www.kb.vmacair.com.



See "System Adjustments (Diagnostics Mode)" on page 53 for instruction to access diagnostic information.

Key Temperatures

Hydraulic fluid too cold: -13 °F (-25 °C) and below	
The hydraulic fluid is too cold and must be warmed prior to starting the system.	
Cooler fan enable	
The cooler fan will automatically turn on under the following conditions (The control system prioritizes compressor oil temperature above the hydraulic fluid temperature):	
<ul style="list-style-type: none"> • The compressor oil temperature reaches 190 °F (88 °C). • The hydraulic fluid temperature reaches 151 °F (66 °C) <u>and</u> the compressor oil temperature is above 171 °F (77 °C). 	
Cooler fan enable cooler fan turns off	
The cooler fan will automatically turn off under the following conditions (The control system prioritizes compressor oil temperature above the hydraulic fluid temperature):	
<ul style="list-style-type: none"> • The compressor oil temperature drops to 162 °F (72 °C) (or below). • The hydraulic fluid temperature reaches 122 °F (50 °C) <u>and</u> the compressor oil temperature is below 171 °F (77 °C). 	
Soft start	
The system will remain in "Soft Start" while the hydraulic fluid and compressor oil temperature are within the following parameters:	
<ul style="list-style-type: none"> • Hydraulic fluid temperature below: 41 °F (5 °C). • Compressor oil temperature below: 158 °F (70 °C). 	
Compressor oil temperature below 90 °F (32 °C) <u>and</u> hydraulic fluid below 41 °F (5 °C).	Compressor will only build to 40 psi.
Compressor oil temperature below 158 °F (70 °C) <u>and</u> hydraulic fluid temperature above 41 °F (5 °C).	Compressor will only build to 120 psi.
Over temperature	
The system will automatically shut down if either of the following conditions occur:	
<ul style="list-style-type: none"> • The hydraulic fluid reaches 190 °F (88 °C). • The compressor oil reaches 280 °F (138 °C). 	

Diagnostic Mode Error Codes

Error Code	Display	Fault	Possible Problem(s)
01	OVER TEMP COMP	Compressor oil is above Compressor temperature is above 280 °F (138 °C) and the system is shutting down.	<ul style="list-style-type: none"> • Low compressor oil level. • Faulty or crushed cooler hoses. • Cooling fan not operating. • Insufficient air-flow or ventilation. • Failed temperature probe or faulty electrical connection. • Incorrect compressor oil used. See "Compressor is getting too hot and is shutting down." on page 80.
02	OVER TEMP HYD	Hydraulic fluid is above 188 °F (87 °C) and the system is shutting down.	<ul style="list-style-type: none"> • Insufficient air-flow or ventilation. • Fan not operating. • Failed temperature probe or faulty electrical connection. • Insufficient hydraulic reservoir size. • Incorrect hydraulic hose size. • Too many restrictions in hydraulic circuit. See "Hydraulic fluid is too hot and the system is shutting down." on page 78.
04	COMP PROBE SHORT	Compressor temperature probe wires shorted or failed.	Repair wiring to probe.
05	HYD PROBE SHORT	Hydraulic temperature probe wires shorted or failed.	Repair wiring to probe.
07	COMP PROBE OPEN	Compressor temperature probe disconnected or failed.	<ul style="list-style-type: none"> • Test temperature probe. • Repair wiring to probe.
08	HYD PROBE OPEN	Hydraulic temperature probe disconnected or failed.	<ul style="list-style-type: none"> • Test temperature probe. • Repair wiring to probe.
11	PRESSURE SENSOR?	Failed pressure sensor or bad electrical connection.	Check pressure sensor and wiring connections.
12	CONNECTION ERR	Faulty electrical connections.	Check electrical connections. Bypass extension harness to test.
		Failed Control Box or Display Box.	Check Control and Display boxes for damage.

Display Box Messages

Warning/Information Message	Warning/Information Description	Corrective Action
HYD OIL TOO COLD	The hydraulic fluid temperature is below -13 °F (-25 °C).	<ul style="list-style-type: none"> Hydraulic fluid must be heated prior to the system starting.
HYD OIL WARMING, HYD xxxF/xxxC	The hydraulic fluid is between -13 °F (-25 °C) and 5 °F (-15 °C).	<ul style="list-style-type: none"> Compressor will not engage until the hydraulic fluid has warmed to 5 °F (-15 °C). Continue circulating hydraulic fluid until system warms sufficiently. If installed, VMAC Cold Climate Kit (P/N: A700280) will enable automatically to speed hydraulic fluid warm up.
SOFT START xxxPSI	The system has started but the compressor oil is too cool for maximum output.	<p>System is in unloaded state until both the compressor oil and hydraulic fluid have reached normal operating temperature.</p> <ul style="list-style-type: none"> Stage 1: Compressor oil below 88 °F (31 °C). Will only build to 40 psi. Stage 2: Compressor oil between 90 °F (32 °C) and 156 °F (69 °C). Will only build to 120 psi. Compressor can now be used.
STANDBY xxxPSI	The air pressure remained higher than the restart pressure for the duration of the standby delay time.	<p>Hydraulic solenoid is deenergized. System monitors air pressure and compressor oil / hydraulic fluid temperatures. If air pressure drops below restart pressure, or compressor oil drops below 158 °F (70 °C), or hydraulic fluid drops below 122 °F (50 °C), the system will restart and run until the system is within the standby parameters again.</p>
CHECK AIR FILTER	The system reminds the operator to check the condition of the air filter every 100 hours.	<p>Check air filter and replace as needed.</p> <p>Message will automatically disappear after 6 hrs of operation.</p>
HRS:XXXX:XX 500S	The system reminds the operator to service the system every 500 hours.	<ul style="list-style-type: none"> Perform 500 hour service on system (P/N: A700156). Once complete, enter Diagnostics Mode and clear the service reminder (see page 71).
BATTERY LOW	Voltage supplied to system is too low.	<p>See "System runs then shuts down, and display goes blank, then scrolls company information." on page 77.</p>

Symptoms

Symptom	Possible Cause	Corrective Action
Air pressure won't build past 40 psi (approx.).	System is in "SOFT START".	Wait for system to warm up.
	Air solenoid failure.	Check air solenoid and wiring.
	Pressure sensor has failed or there is a problem with electrical connections.	Check pressure sensor and wiring.

Symptom	Possible Cause	Corrective Action
Low air pressure.	Air receiver tank drain open.	Close air receiver tank drain.
	Air leak.	Check air hoses and fittings for damage or wear.
	Air demand too high.	<ul style="list-style-type: none"> Reduce air consumption. Install air receiver tank (see accessories on page 87).
	Blowdown system stuck open.	Check for air venting from the blowdown cap while the system is running.
	Air solenoid failure.	Check air solenoid and wiring.
	Not enough hydraulic flow.	Connect a hydraulic flow meter with pressure gauge. <ul style="list-style-type: none"> Ensure adequate hydraulic flow and pressure for the application and desired cfm (see page 17). Ensure engine rpm is being maintained when load is applied.
	Hydraulic motor failure.	Perform case drain flow test.

Symptom	Possible Cause	Corrective Action
Air pressure relief valve opens.	Compressor system pressure exceeding 200 psi.	<ul style="list-style-type: none"> Install pressure gauge at AOST outlet to confirm pressure is above 200 psi. Check pressure sensor.
	Air pressure relief valve failure (opens below 200 psi).	Replace pressure relief valve.
	Unload solenoid has failed energized.	Check solenoid and wiring.
	Inlet poppet O-ring dislodged.	Contact VMAC Technical Support.
	PTFE Pressure Control tube disconnected or failed.	Check PTFE tube between air solenoid and inlet valve.

Symptom	Possible Cause	Corrective Action
No power to display box.	Blown fuse or bad connection.	<ul style="list-style-type: none"> • Check display box connections. • Replace fuse inside unit.
	No power from Control Box.	Check for 12 V from Control Box to Display Box.

Symptom	Possible Cause	Corrective Action
System does not start when activated.	Start up conditions not met.	Refer to "System Operation (What to Expect at Start Up)" on page 47.
	Hydraulic solenoid failure.	Check solenoid and connections.
	Hydraulic motor or compressor seized.	Try to rotate compressor and hydraulic motor.
	Faulty Control Box connections.	Verify Control Box ground.

Symptom	Possible Cause	Corrective Action
System runs then shuts down, and display goes blank, then scrolls company information.	Issue with supplied power.	<ul style="list-style-type: none"> • Wire gauge from vehicle battery is too small. Install the correct gauge of wire (see page 26 or page 29). • Check electrical connections. • Measure voltage at the input to the Hydraulic Driven Air Compressor when it is running and with the fan on to ensure full voltage. • Check charging system.

Symptom	Possible Cause	Corrective Action
Excessive water in compressor oil.	Very short duty cycle.	<ul style="list-style-type: none"> • Install air receiver tank. • Perform 500 hour service (P/N: A700156).
	Cooling fan always running.	<ul style="list-style-type: none"> • Perform 500 hour service (P/N: A700156). • See "Key Temperatures" on page 73. <p>If the system is running within the parameters, contact VMAC technical support.</p>

Symptom	Possible Cause	Corrective Action
"DIAGNOSTICS" showing on the display box as soon as system is powered on.	"OFF" button is stuck on.	Replace keypad.

Symptom	Possible Cause	Corrective Action
Hydraulic fluid is too hot and the system is shutting down. Hydraulic fluid above 188 °F (87 °C).	Insufficient air-flow or ventilation.	<ul style="list-style-type: none"> • Ensure cooler is not blocked. • Open cabinet door (if installed in an enclosure). • Improve ventilation. • Move Hydraulic Driven Air Compressor out of cabinet.
	Fan not operating.	<ul style="list-style-type: none"> • Check fan and relay. • Check connections.
	Failed temperature probe or bad electrical connection.	Check temperature probe and wiring connections.
	<ul style="list-style-type: none"> • Insufficient hydraulic reservoir size. • Incorrect hydraulic hose size. • Too many restrictions in hydraulic circuit. 	Have hydraulic circuit inspected/tested by qualified hydraulic specialist.

Symptom	Possible Cause	Corrective Action
Excessive oil in the air stream (oil carry over).	Compressor was shut down while building air.	Stop air demand and allow system to build to full system pressure (150 psi) prior to turning the compressor off.
	Unit operating on grade greater than 15°.	Level the vehicle and run the system. Oil carry over may take up to 45 minutes to dissipate.
	Lack of service.	Service unit every 500 hours or annually, whichever occurs first.
	AOST overfilled.	Correct the oil level.
	Failed coalescing filter.	Replace coalescing filter.
	Clogged scavenge screen.	Clean scavenge screen (see page 58).
	Poor fit between coalescing filter and AOST/poor seal at O-rings.	Replace parts as necessary.

Symptom	Possible Cause	Corrective Action
Oil out the air filter / air filter saturated with oil.	Not enough hydraulic flow.	Connect a hydraulic flow meter with pressure gauge. <ul style="list-style-type: none"> • Ensure adequate hydraulic flow and pressure for the application and desired cfm (see page 17). • Ensure engine rpm is being maintained when load is applied.
	Using a variable displacement hydraulic pump.	<ul style="list-style-type: none"> • "Pressure Compensated" variable displacement, pump: Install VMAC Closed Center Manifold (see page 89). • "Load Sensing" variable displacement pump: Contact VMAC Technical Support.
	Hydraulic motor failure.	Perform case drain flow test.

Symptom	Possible Cause	Corrective Action
Water in the air stream.	No Filter/Regulator/Lubricator (FRL) installed.	Install FRL.
	FRL failure (if installed).	Check drain on filter.
	Air receiver tank not drained regularly (if installed).	Drain air receiver tank daily.
	Excessive water in compressor oil.	Perform 500 hour service (P/N: A700156). See "Excessive water in compressor oil." on page 77 to troubleshoot.

Symptom	Possible Cause	Corrective Action
Compressor is getting too hot and is shutting down. Compressor temperature is above 280 °F (138 °C).	Low compressor oil.	Add oil as necessary (see page 60). See "Excessive oil in the air stream (oil carry over) " on page 78 to troubleshoot.
	Compressor oil flow restricted.	<ul style="list-style-type: none"> • Check oil filter for blockage. • Remove hoses and check for blockage. • Check cooler for blockage.
	Cooling fan not operating.	<ul style="list-style-type: none"> • Check fan and relay. • Check connections.
	Insufficient air-flow or ventilation.	<ul style="list-style-type: none"> • Ensure cooler and air filter are not blocked. • Open cabinet door (if installed in an enclosure). • Improve ventilation. • Move Hydraulic Driven Air Compressor out of cabinet.
	Failed temperature probe or bad electrical connection.	Check temperature probe and wiring connections.
	Incorrect compressor oil used.	Incorrect compressor oil used.

Hydraulic Testing



Ensure the hydraulic oil has cooled and that the and air and hydraulic systems are depressurized prior to performing any testing or servicing on the system.



Ensure all hoses, fittings and gauges used during testing are rated for the operating pressure of the system being tested.



These instructions are provided as a general guideline only and are not considered to be comprehensive.

VMAC is unable to provide hydraulic circuit designs or consult on specific hydraulic installations. If the system does not meet VMAC's requirements, we recommend consultation with a hydraulic specialist.

A hydraulic flow meter with pressure gauge is necessary to verify that the hydraulic circuit powering the VMAC Hydraulic Driven Air Compressor is within specification (Figure 39).

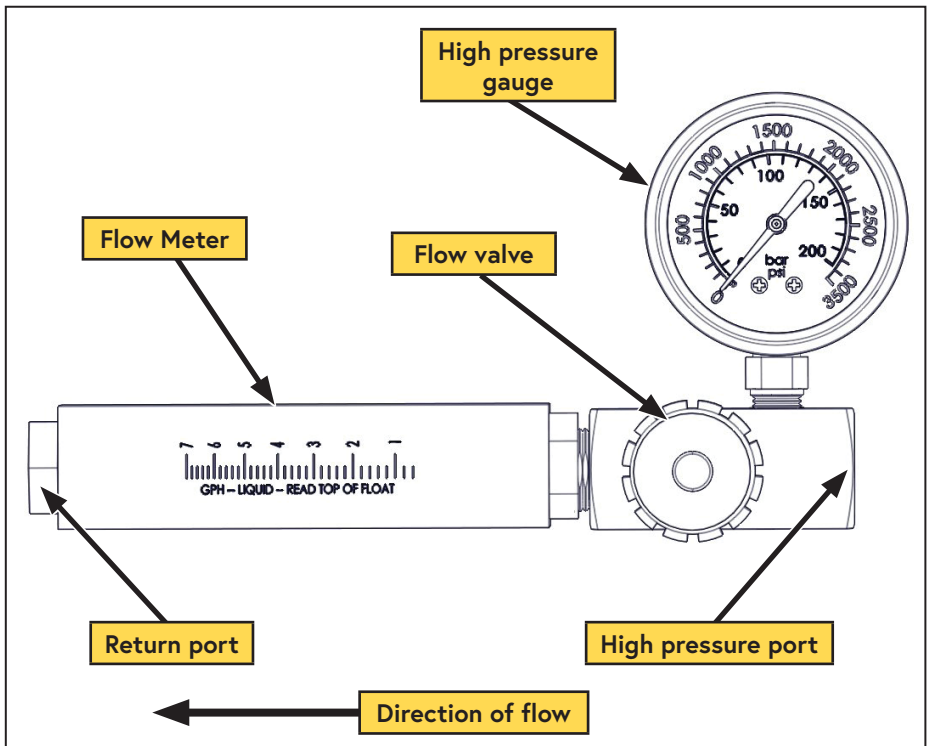

Figure 39 — Hydraulic test tool

Compressor Test

- Connect the hydraulic test tool in-line into the "PRESSURE IN" side of the hydraulic manifold (Figure 40).

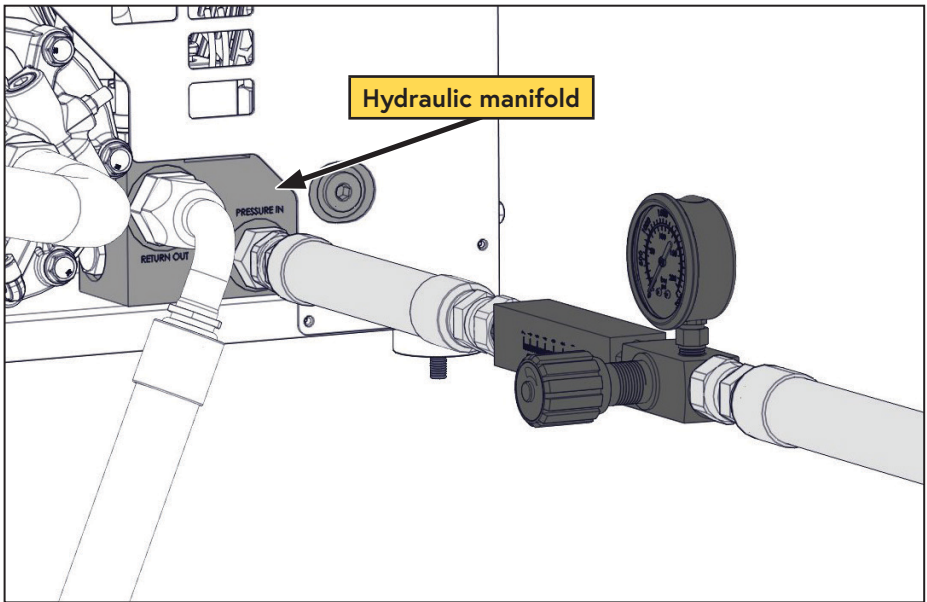

Figure 40 — Install hydraulic test tool

- With the hydraulic test tool valve opened completely, activate the hydraulic system.
- Observe the flow meter and ensure the flow is within system specification:
 - H40: 9 gpm – 14 gpm.
 - H60: 14 gpm – 21 gpm.
 - H60 HHP: 12 gpm – 18 gpm.
- Observe the pressure gauge and ensure the hydraulic pressure is within system specification:
 - H40: 900 psi – 2,400 psi.
 - H60: 900 psi – 2,400 psi.
 - H60 HHP: 900 psi – 2,700 psi.
- Activate the compressor.
- Observe the flow meter and ensure the hydraulic flow remains within the specifications listed above.
- Observe the pressure gauge and ensure the pressure is below:
 - H40: 2,600 psi.
 - H60: 2,600 psi.
 - H60 HHP: 2,900 psi.

Hydraulic Pump Test (Bypassing the VMAC System)



The following test ensures the VMAC Hydraulic Driven Air Compressor is receiving the required hydraulic pressure and flow.

- Remove the line connected to the "PRESSURE IN" port of the VMAC Hydraulic Driven Air Compressor and connect it to high pressure port of the hydraulic test tool (Figure 41).

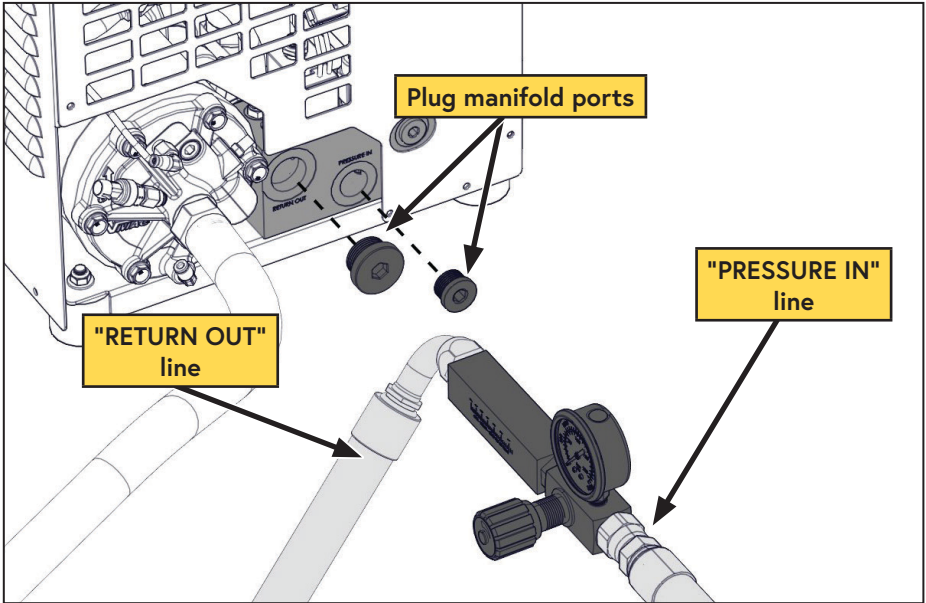

Figure 41 — Install hydraulic test tool

- Remove the line connected to the "RETURN OUT" port of the VMAC Hydraulic Driven Air Compressor and connect it to return port of the hydraulic test tool (Figure 41).
- Plug ports on the VMAC hydraulic manifold to prevent contaminants from entering the system (Figure 41).
- With the hydraulic test tool valve opened completely, activate the hydraulic system.
- Observe the flow meter and ensure the flow is within system specification:
 - H40: 9 gpm – 14 gpm.
 - H60: 14 gpm – 21 gpm.
 - H60 HHP: 12 gpm – 18 gpm.
- Observe the pressure gauge and ensure the pressure is below:
 - H40: 2,600 psi.
 - H60: 2,600 psi.
 - H60 HHP: 2,900 psi.

VMAC - Vehicle Mounted Air Compressors

VMAC Technical Support: 888-241-2289

VMAC Knowledge Base: kb.vmacair.com

- Using the valve on the hydraulic test tool, increase the pressure to 2,700 psi (this simulates the load created by the VMAC Hydraulic Driven Air Compressor).



If the system will not reach 2,700 psi, the hydraulic circuit is not meeting the minimum requirements to run the VMAC Hydraulic Driven Air Compressor.

VMAC suggests working with a local hydraulic expert to diagnose any issues or adjust the hydraulic circuit.

- Observe the flow meter and ensure the hydraulic flow remains within the specification:
 - H40: 9 gpm – 14 gpm.
 - H60: 14 gpm – 21 gpm.
 - H60 HHP: 12 gpm – 18 gpm.
- Observe the pressure gauge and ensure the pressure is below:
 - H40: 2,600 psi.
 - H60: 2,600 psi.
 - H60 HHP: 2,900 psi.

Air Receiver Tank



Pressure in the air receiver tank will not be relieved when the compressor system blows down. This is normal operation. Prior to performing any service work on the system, discharge any stored air in the air receiver tank.



The system has a built-in check valve. Use of an additional check valve is not required and may cause erratic performance.



If an air receiver tank will be used with this system, the following installation procedure must be used to prevent damage to the system.

The VMAC compressor system will automatically depressurize when shutdown. The AOST has a built in check valve that prevents blow back and moisture from the receiver tank entering the AOST. Installation of an additional check valve will cause erratic performance.

While the air receiver tank can be installed at any height in relation to the AOST, the discharge hose running from the AOST must be installed as high as possible on the air receiver tank to prevent problems with condensation that may have accumulated in the receiver tank (Figure 42).

Drain the condensed water from the receiver tank daily.

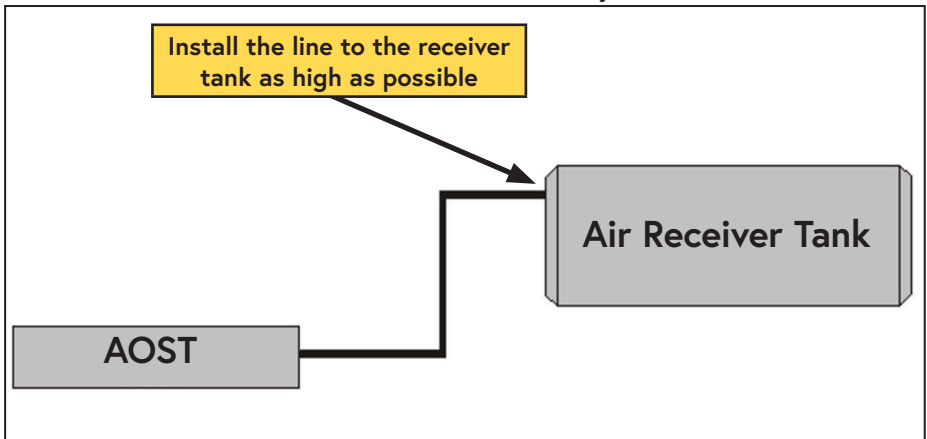

Figure 42 — Air receiver tank

Recommended Accessories

While the compressor system will function without the following accessories, VMAC strongly recommends their use for optimal performance.

See the "Accessory Product" section of this manual on page 87 for a list of products available for purchase through VMAC.

Receiver Tank

An air receiver tank provides a buffer as it gives the compressor time to react by increasing the engine speed and producing air before the tool stalls. It also has the advantage of lowering the duty cycle of the compressor system.

Pressure Gauge

While not critical to system performance, a pressure gauge is important for fine tuning the system and simplifies any potential troubleshooting.

Install a 200 psi pressure gauge downstream of the air discharge valve.

Pressure Regulator and/or Lubricator or FRL

The compressor can produce air pressures up to approximately 150 psi (1035 kPa). It is the responsibility of the user to know the pressure and air flow requirements of the tools powered by the air compressor system.

An appropriate air pressure regulator and lubricator can be installed downstream of the air discharge valve. Failure to regulate the air pressure may cause damage to the tool.

Accessory Products from VMAC

Compressor Service Kits



**500 Hour or 6 Month / 1 Year Service Kit -
Part number: A700156**

Includes VMAC high performance compressor oil, oil filter, air filter, coalescing filter, pressure relief valve, and next service due decal.

Air Aftercooler — 70 cfm

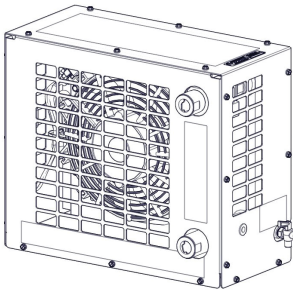

Part number: A800070

Improves tool performance and extends the life of air tools; removes up to 80% of water from compressed air; includes automatic water drain.

- Max air flow: 70 cfm / 175 psi.
- Port size: 3/4 in NPT inlet and outlet.
- Electrical: 12 V.
- Dimensions: 17 in (43.2 cm) L x 8.0 in (20.3 cm) W. x 14.5 in (36.8 cm) H.
- Weight: 35 lb (15.8 kg).

Filter Regulator Lubricator (FRL) — 70 cfm

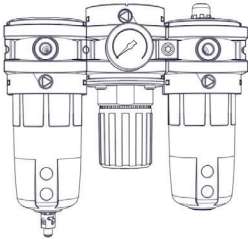

Part number: A700151

Extends the life of air tools; filter removes contaminants from the compressed air, adjustable regulator can reduce air pressure going to tools, lubricator adds atomized tool oil to the air stream to lubricate air tools (Tool oil not included).

- Max air flow: up to 70 cfm / 150 psi
- Port size: 3/4 in NPT inlet and outlet

1/2 in x 50 ft Hose Reel

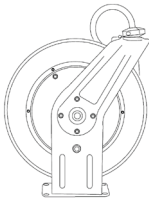

Part number: A700007

Spring-loaded 1/2 in x 50 ft hose reel; steel construction; full flow shaft and swivel for maximum performance.

6 Gallon Air Receiver Wing Tank

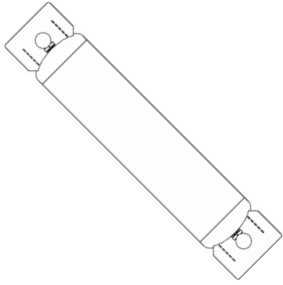

Part number: A300056

Air receiver tanks are used for lowering compressor duty cycle and removing water from compressed air; recommended for optimum operation of all VMAC Gas Driven, Diesel Driven, Hydraulic, and UNDERHOOD40 air compressors. Manufactured to FMVSS 121 standard; includes fittings, 170 psi pressure relief valve, and tank drain.

- Max pressure: up to 170 psi.
 - Dimensions: 32 in (81.3 cm) L x 8 in (20.3 cm) D.
 - Weight: 23 lb (10.4 kg).
-

10 Gallon Air Receiver Tank w/ Mounting Feet



Part number: A300047

Air receiver tanks are used for lowering compressor duty cycle and removing water from compressed air. Recommended for optimum operation of VMAC Hydraulic Air Compressors, VMAC Diesel Driven Air Compressors, UNDERHOOD40, UNDERHOOD70 – Green Series Air Compressors, and VMAC Multifunction Power Systems, which include standby mode; ASME certified; includes fittings, 200 psi pressure relief valve, tank drain, and 200 psi pressure gauge.

- Max pressure: up to 200 psi.
 - Dimensions: 30 in (76.2 cm) L x 10 in (25.4 cm) D.
 - Weight: 33 lb (15 kg).
-

35 Gallon Air Receiver Wing Tank

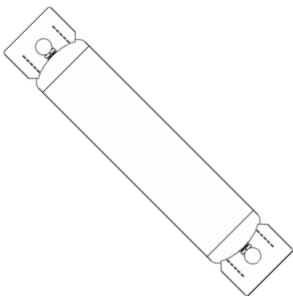

Part number: A300010

Air receiver tanks are used for lowering compressor duty cycle and removing water from compressed air. Recommended for optimum operation of VMAC Diesel Air Compressors, Hydraulic Air Compressors, UNDERHOOD40, UNDERHOOD70 – Green Series Air Compressors, and VMAC Multifunction Power Systems, which include standby mode; ASME certified; includes fittings, 200 psi pressure relief valve, tank drain, and 200 psi pressure gauge.

- Max pressure: up to 200 psi.
 - Dimensions: 73 3/4 in (187.3 cm) L x 14 in (35.6 cm) D.
 - Weight: 95 lb (43.1 kg).
-

Hydraulic Oil Cooler

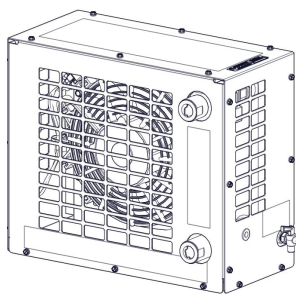

Part number: A850001

Recommended for high duty cycle industrial and work truck hydraulic systems working in hot climates (100 °F (37 °C) and above); capable of removing up to 33,750 BTU / Hr.

- Hydraulic flow: 5 - 20 GPM (19 - 76 LPM)
- Pressure rating: Up to 500 psi (345 kPa)
- Electrical: 12 V @ 10 Amps
- Dimensions: 17.0 in (43.2 cm) L x 8.0 in (20.3 cm) W x 13.0 in (33 cm) H
- Weight: 30 lbs (13.5 kg)

Closed Center Manifold

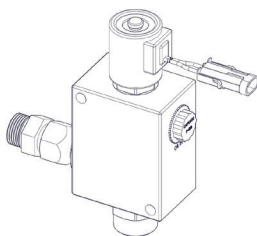

H40 (40 cfm): A700190

Allows VMAC's Hydraulic driven air compressor systems to be used with pressure compensated variable displacement (closed center) hydraulic systems.

Note: The VMAC Closed Center Manifold is not compatible with "load sensing" variable displacement hydraulic systems.

Cold Climate Kit

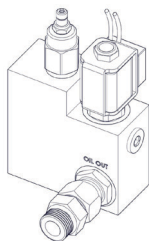

Part number: A700280

Fully automated manifold heater block; recommended for extreme cold climates; when hydraulic oil temperatures fall below 5°F (-15°C), a solenoid will energize and heat the hydraulic oil.

Error and Service Logs

See "System Adjustments (Diagnostics Mode)" on page 53 for instruction on how to retrieve the error messages.

Once the form is filled out it can be emailed to tech@vmacair.com or faxed to (877) 740-3203.

Name: _____ Company: _____

Phone#: _____ Email: _____

VMAC Service Ticket (If issued): _____ Preferred VMAC Dealer (Optional): _____

VMAC System ID: _____ OR Compressor Serial Number: _____

Total hours on unit: _____

Logged Error 1 Hours: _____

Logged Error 2 Hours: _____

Logged Error 3 Hours: _____

Logged Error 4 Hours: _____

Logged Error 5 Hours: _____

Logged Error 6 Hours: _____

Logged Error 7 Hours: _____

Logged Error 8 Hours: _____

Logged Error 9 Hours: _____

Logged Error 10 Hours: _____

Warranty Registration

This form must be fully completed and returned to VMAC at the time the vehicle is put into service. Warranty may be void if this form is not received by VMAC within 3 months of receiving the vehicle, or 200 hours of operation, whichever occurs first.



VMAC's Warranty policy and registration can be viewed online at:

www.vmacair.com/warranty

Product Information

System Identification Number: H _ 0 0 0 0 _ _ _ _ _

Owner / End User Information

Company Name: _____

City: _____ State / Province: _____

Phone: (____) ____-_____

Email Address: _____

Date vehicle was put into service: ____/____/____
Day Month Year

Installer Information

Installer Company Name: _____

City: _____ State / Province: _____

Submitted by

Name: _____ Phone: (____) ____-_____

Email Address: _____

Vehicle Information (Optional)

Unit: _____ Year: _____

Make: _____ Model: _____

Vehicle Identification Number: _____

Manufactured by



888-241-2289



tech@vmacair.com



877-740-3202



warranty@vmacair.com



www.vmacair.com



kb.vmacair.com



1333 Kipp Road, Nanaimo, B.C., V9X 1R3 Canada