



# Compressed Air Filtration Technologies

DF Series | 810 Series | DTA Series | ME Series | Color-Change





# Clean Compressed Air Protects Profits and Processes

Since 1961, compressed air users have relied on Deltech to deliver technology that reduces the cost of operation and improves the reliability of air driven processes in sensitive applications. Quality Deltech filtration products reduce energy consumption and protect pneumatic operations to protect the profits of industry.

Dirt, rust, pipe scale, water and lubricant carryover are all byproducts of compressed air generation. Left unfiltered, this abrasive stream of contaminants will compromise the operation, integrity, and usable service life of pneumatically powered operations. Unnecessary wear and tear artificially inflates operating costs, adds to product rejects, and wastes countless hours on unscheduled equipment maintenance. Furthermore, the presence of oily water dilutes the effectiveness of in-line oil lubricators. These unwanted contaminants bind valves and motion control devices, corrode air motors, and contaminate finished goods.



*DF Series Filter  
Shown with optional  
Pressure Monitor*

## Deltech Filtration Products

Model	Flow (scfm)	Solid Particles (down to micron)	Remaining Oil Content (ppm by weight)	Pressure Drop at Rated Conditions psid (bar)		Applications and Features
				Dry	Wet	
<b>DF Series</b>						
Grade A	20-21,250	0.01	0.0008	2(0.14)	6(0.42)	Maximum Efficiency Oil Removal
Grade B	20-21,250	0.01	0.008	1 (0.07)	3 (0.21)	High Efficiency Oil Removal
Grade C	20-21,250	1	1	1 (0.07)	2 (0.14)	General Purpose
Grade D	20-21,250	3	5	1 (0.07)	1.5 (0.11)	Separator/Filter
Grade E	20-21,250	-	-	0.8 (0.06)	0.8 (0.06)	Water Separator
Grade Y	20-21,250	1	-	1 (0.07)	-	Dry Particulate
Grade Z	20-21,250	0.01	0.003	1 (0.07)	-	Oil Vapor Removal
<b>DTA Series</b>	100-11,400	1.0	N/A for High Temperature Applications	1 (0.07)	N/A	High Temperature Dry Particulate
<b>810 Series</b>	1,000-15,000	0.01	0.001	0.4 (0.03)	3.5 (0.24)	Heavy oil loading, low pressure drop
<b>ME Series</b>	125-3,000	0.1	0.5	0.5 (0.03)	0.5 (0.24)	Low pressure drop 10 year element life

## Three Typical Contaminant Types...

- 1) Solid particles come from ambient air contaminants like dust and from rusted, oxidized pipework. They will cause pneumatic equipment to malfunction, cause instrument and control failures, and contaminate end products.
- 2) Condensed water droplets come from the humidity in ambient air. Water will oxidize pipework and pneumatic equipment, ruin paint finishes and end products.
- 3) Liquid oil and oil vapors are introduced by compressor lubricants and by hydrocarbon vapors present in ambient air. Oil-free compressed air is particularly important in food and pharmaceutical processes.



## Serious Savings with Pressure Monitor

Titans of industry know how costly compressed air generation can be. Companies that are serious about reducing costs generally consult professional compressed air system auditors to analyze their air generation systems and plant air demands so they can strategize on areas to eliminate waste and improve efficiencies. It is no wonder that many Filters are ordered and installed with an optional Pressure Monitor.

## Annual Energy Saving Potential

Flow SCFM	System Pressure Reductions				
	2 psig	4 psig	6 psig	8 psig	10 psig
100	\$143.77	\$ 287.54	\$ 431.31	\$ 575.08	\$ 718.85
250	359.42	718.85	1,078.27	1,437.69	1,797.11
500	718.85	1,437.69	2,156.54	2,875.38	3,594.23
1000	1,437.69	2,875.38	4,313.07	5,750.76	7,188.46
2000	2,875.38	5,750.76	8,626.15	11,501.53	14,376.91
5000	7,188.46	14,376.91	21,565.37	28,753.82	35,942.28
10,000	14,376.91	28,753.82	43,130.74	57,507.65	71,884.56

\* Assumes 5 scfm/HP, \$0.10 per kWh, 8,760 hours of operation per year  
 Pressure Monitor's accuracy lets you manage element condition to reduce costly system pressure.  
 Example: 500 scfm air system - change filter element at 2 psig vs. 10 psig to add \$2,875.38 to your bottom line.

## Take Control

Pressure Monitor uses advanced microprocessor technology to help you take control with 3 complementary modes of operation - as standard.

- Time Monitoring Mode - provides notification when it is time to change the filter element per your selection from 1-15 months.
- Differential Pressure Mode - select the exact pressure differential you will tolerate to initiate the warning to minimize the cost of pressure drop.
- Filter Performance Mode - Pressure Monitor automatically analyzes your systems flow dynamics 1,800 times per hour to chart its unique operating characteristics. It references the parameters you selected and continually plots your system's profile to forecast the days left until it will cost more to operate the dirty element than to replace it. A warning is triggered 60 days before change-out is recommended and the day's countdown until the filter element is changed.



## DF Series Filters

### An Innovative Design for all Applications

DF Series Filters incorporate industry-leading technology in user-friendly, World-Class Designs. Offering the most comprehensive range of elements in the industry, select from 7 Grades of application engineered elements to arrive at the best system to meet your air quality requirements.

#### Gauge

- Standard on 100 - 21,250 scfm models
- Dual gauge face allows housings to be mounted in any flow direction
- Indicates element change-out based on differential pressure
- Large easy-to-read gauge face
- Remote mounting possible

#### Simple Maintenance

- 1/8" turn, self-locking bayonet head to bowl connection (up through 1" connection sizes)
- Audible warning by escaping air if housing is not depressurized before disassembly
- Ribbed bowls allow use of C-spanner
- Color-coded elements for easy identification

#### Modular Housings Save Space and Time

- Standard on 20 - 780 scfm models
- Large flow paths reduce pressure drop
- Chromated and epoxy powder painted (interior and exterior) add durability and corrosion resistance
- MWP 300 psig (21 bar)
- Can be mounted for left or right entry
- High-quality aluminum, zinc, and steel materials



#### Energy Saving

##### Pressure Monitor

- Optional on all models
- Three modes determine element change: time, differential pressure, element performance



##### Slide Indicator

- Standard on 20 - 60 scfm models
- Changes color based on differential pressure



#### Element Grades Offer Superior Filtration

- Large effective surface areas ensure high capture rates
- Large open areas minimize pressure drop
- Silicone-free, withstand temperatures to 150°F (66°C)
- Push-on elements for quick replacement
- Corrosion resistant, stainless steel cores

#### Internal Automatic Drains

- Reliable discharge of condensate
- Pilot operated, pneumatically actuated, particulate-resistant mechanism
- Viton seals and inlet screen for additional protection



### As easy as 1, 2, 3

The job of an DF Series Filter Element is to remove contaminants from your air system. Contaminants gradually build-up on the element and restrict flow thereby reducing pressure.

Regular maintenance allows your system to operate at peak energy efficiency while reducing maximum system pressure to save on power costs. Replacing a fouled element at the right time reduces pressure loss and repays the cost of the element many times over. Modular DF Series Filters make sure maintenance is as easy as 1, 2, 3.

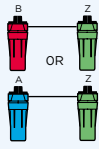

## Filtration from A to Z

Element Type	Description	CAGI, PNEUROP, and ISO Performance Data	Where	
<b>Grade A</b>  Ultra High Efficiency Oil Removal Element	Ultra fine coalescer for oil free air for critical applications <ul style="list-style-type: none"> <li>Where air contacts product</li> <li>Conveying</li> <li>Agitating</li> <li>Electronics manufacturing</li> <li>Nitrogen replacement</li> </ul>	<b>Removes:</b> Solids and liquids 0.01 micron and larger 99.999+% of oil aerosols; remaining oil content 0.0008 ppm ISO 8573.1 Quality Class - Solids: Class 1, Oil Content: Class 1 Maximum inlet liquid load: 100 ppm w/w	Upstream of desiccant or membrane dryers; use a Grade 7 as a prefilter if heavy liquid loads are present Downstream of refrigerated dryers	
<b>Grade B</b>  High Efficiency Oil Removal Element	Fine coalescer for oil free air for industrial use <ul style="list-style-type: none"> <li>Painting</li> <li>Injection molding</li> <li>Instruments</li> <li>Control valves</li> </ul>	<b>Removes:</b> Solids and liquids 0.008 micron and larger 99.99+% of oil aerosols; remaining oil content 0.01 ppm w/w ISO 8573.1 Quality Class - Solids: Class 1, Oil Content: Class 2 Maximum inlet liquid load: 1,000 ppm w/w	Upstream of desiccant or membrane dryers Downstream of refrigerated dryers Downstream of pressure-swing desiccant dryers for fine Particulate removal At point-of-use (may be used if light liquid load is present)	
<b>Grade C</b>  Air Line Element	General Purpose 1 micron coalescer for shop air operating <ul style="list-style-type: none"> <li>Tools</li> <li>Motors</li> <li>Cylinders</li> </ul>	<b>Removes:</b> Solids and liquids 1 micron and larger Remaining oil content 1 ppm w/w ISO 8573.1 Quality Class - Solids: Class 2, Oil Content: Class 4 Maximum inlet liquid load: 2,000 ppm w/w	Upstream of ultra high efficiency oil removal filters At point-of-use if aftercooler/separator installed upstream	
<b>Grade D</b>  Separator / Element	Mechanical separator and 3 micron coalescer removes <ul style="list-style-type: none"> <li>Liquid</li> <li>Large particles</li> </ul>	<b>Removes:</b> Solids and liquids 3 microns and larger Remaining oil content 5 ppm w/w ISO 8573.1 Quality Class - Solids: Class 3, Oil Content: Class 5 Maximum inlet liquid load: 25,000 ppm w/w	At point-of-use if no aftercooler/separator used upstream	
<b>Grade E</b>  Water Separator Element	Bulk Liquid Separator <ul style="list-style-type: none"> <li>Bulk Liquid</li> </ul>	<b>Removes:</b> Liquids and Solids 10 microns and larger Maximum inlet liquid load: 30,000 ppm w/w	Downstream of aftercoolers	
<b>Grade Y</b>  Dry Particulate Element	Dry Solids Removal <ul style="list-style-type: none"> <li>Pipeline Protection from abrasive desiccant dust</li> </ul>	<b>Removes:</b> Solids 1 microns and larger No liquid should be present at filter inlet	Downstream of pressure-swing (heatless) desiccant dryers	
<b>Grade Z</b>  Oil Vapor Removal Element	Activated carbon filter for odor free air for <ul style="list-style-type: none"> <li>Food and drug manufacturing</li> <li>Breathing air</li> <li>Gas processing</li> </ul>	<b>Removes:</b> Oil vapor: remaining oil content 0.003 ppm w/w (as a vapor) Solids 0.01 micron and larger ISO 8573.1 Quality Class - Solids: Class 1, Oil Content: Class 1 No liquid should be present at filter inlet - use a high efficiency oil removal filter upstream of Grade Z filters to prevent liquid oil contamination	Downstream of high efficiency oil removal filters	
<b>Filter Type</b>				
<b>DTA Series</b>  High Temperature Dry Particulate	High Temperature Dry Particulate After Filter	<b>Removes:</b> Solids 1 micron and larger No liquid should be present at filter inlet	Downstream of heat reactivated desiccant dryers	

# 810 Series Filters

## Save Space and Save Energy from 1,000 to 15,000 scfm

Deltech 810 Series Filters are designed to integrate all filtration into one single housing. The result of using one filter instead of two is high quality filtration with much less installation space required and lower pressure drops. 810 Series Filters feature:

- Space-savings: one filter housing provides solid particulate filtration to 0.01 micron and oil aerosol and droplet filtration to 0.001 ppm
- Energy-savings: wetted element pressure drop of only 3.5 psig - compared to total wetted pressure drop of 7 psig required when using two filters to achieve the same filtration performance.
- Less maintenance: air flow design prolongs element life and service intervals. Air enters the filter and bulk water and particulates are removed through centrifugal separation. Multiple layers of coalescing media, with gradually decreasing pore sizes, impinge solid particles and coalesce liquid mists as the air travels through the filter media.

Models 820 through 829

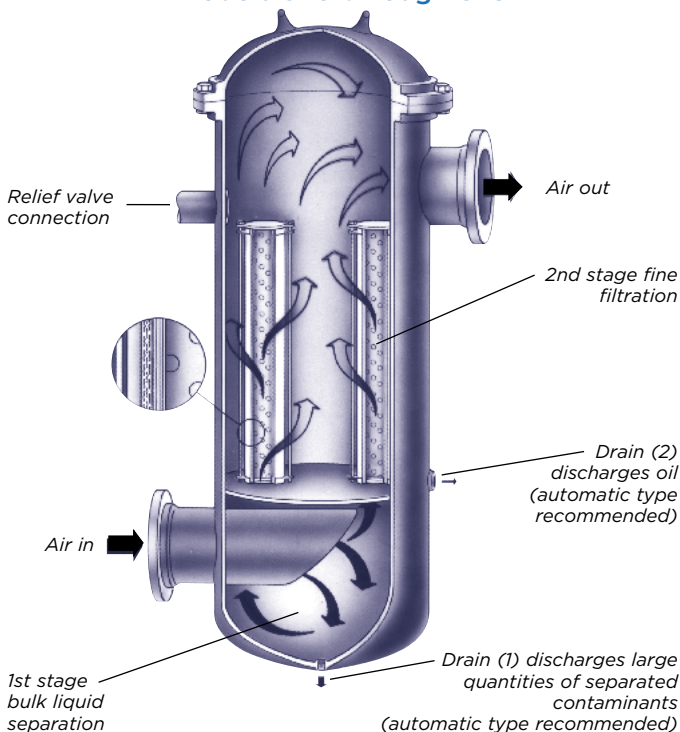

## Materials & Construction <sup>a, b</sup>

Component	Material for Models 820-829 <sup>1</sup>
Vessel head, bowl	Cast aluminum alloy
Bolts	A 449
Nuts	A 194, Grade 2H
Surface finish	Painted
Gasket	-
O-rings	Buna N
Element:	
Filter media	Glass fiber
End caps	Stainless steel and nylon
Support core	Perforated carbon steel

Maximum operating temperature: 150°F (65°C)

Maximum recommended filtration temperature: 120°F (49°C)

Minimum inlet filtration temperature: 34°F (1°C)

<sup>1</sup> Maximum pressure: 150 psig

<sup>a</sup> Element and materials of construction are compatible with most compressor lubricants, except phosphate ester base types.

<sup>b</sup> All filters are registered within all provinces of Canada and are provided stamped with CRN registration numbers.

# ME Series Mist Eliminators

## Designs for Lowest System Pressure Drops

Air auditors always consider ME Series Mist Eliminators due to the 0.5 psig wetted pressure drop of the filter element. The unique housing and filter design is becoming the solution of choice for compressed air users who have decided to reduce the air compressor horsepower required to maintain stable air pressures in their plant. The ME Series provides many unique benefits:

- Flows from 125 through 3,000 scfm
- Energy Savings: 0.5 psig wetted-element pressure drop vs 4-7 psig for comparable filtration performance from traditional designs
- 10 Year Element Life: reduce maintenance costs by not having to change elements once a year
- Performance: remove 99.95% of solid particulates and liquids to 0.1 micron. Remove oil droplets and mists to 0.5 ppm
- Flood protection: the generously-sized housing and filter element designs provide insurance against the downstream damage a flood of water can cause should the condensate drains of the upstream aftercoolers next to the air compressors fail
- Differential pressure indicator is standard



ME Series filter  
Shown with optional  
NLD-24T Drain Valve

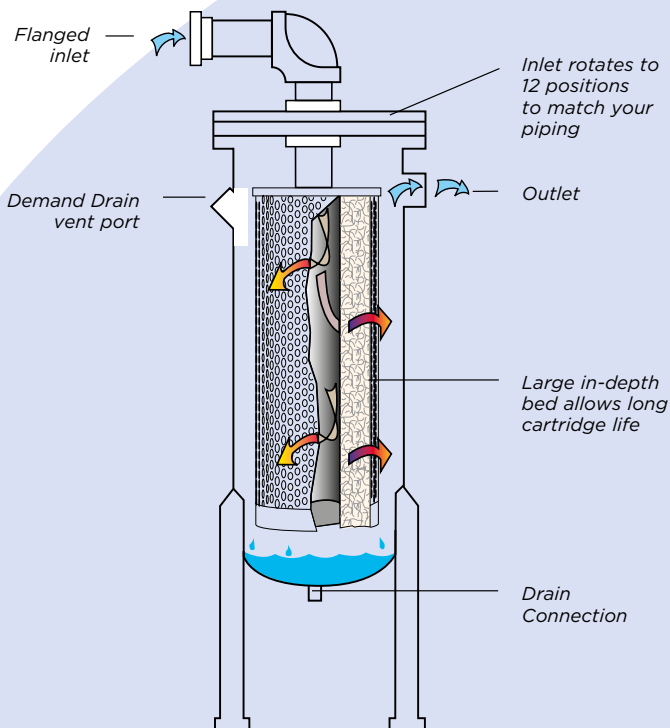

## How it Works

The compressed air stream enters the interior cavity of the filter element via the top inlet connection. Dense layering of filter media allows the irregular, zigzagging Brownian motion to progressively capture finer liquids and particulates on each layer. Smooth laminar flow characteristics maintain efficiency and low pressure drop across the entire range of flow. Coalesced liquids drain by gravity into the sump. Re-entrainment is prevented due to low velocities. A dedicated drainage port is provided.

## 100 Series

**Color-change inspection at a glance**  
Quick, easy check on oil removal: element turns red to signal on-time replacement for continuous high performance

**Built-in prefiltration**  
Brushes, wire mesh, air direction changes and velocity drop remove coarse contaminants and liquids to protect replacement element and reduce pressure drop

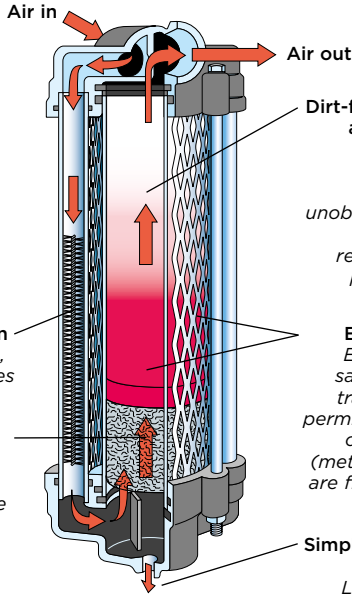

**Dirt-free coalescing and adsorption media**  
Air flows freely through unobstructed paths: pressure drop remains low (2-3 psi) throughout element life

**Easy inspection**  
Expanded mesh safety shield and transparent tube permit clear viewing of color-change (metal tube models are fitted with sight ports)

**Simple contaminant discharge**  
Large sump and high capacity drain connection allow convenient discharge of separated contaminants; automatic drain valve recommended for most reliable performance

## KC Series

Heavy particles impinge and drop out of the air stream

Smaller particles are scrubbed out by coarse brushes

separated particles and bulk liquids drop into sump

Oil mist coalesces into larger droplets and drain into sump

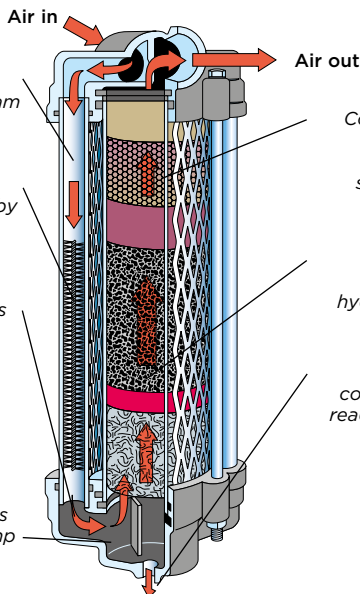

Color band turns from purple to brown to signal cartridge replacement

Oil vapor and other gaseous hydrocarbons are absorbed

Separated contaminants are readily discharged through high capacity drain connection

## Deltech Color Change Filtration 100 Series...the Original Deltech Filter

In 1961, the original award winning Deltech 100 Series color change filters redefined compressed air filtration. The 100 Series Filter delivers 3-stage filtration for the majority of common uses. Designed to remove oil mists, a transparent densely packed column of polymeric resin granules turn red when saturated with oil. A transparent tubular housing ensures high visibility.

100 Series Filters deliver:

- Efficient Filtration... exceeds 99.99% lubricant and water aerosol removal at 0.5 micron particle size; featuring 95% coalescing stage particle and droplet removal by weight
- Low Pressure Drop... only 2-3 psi initial pressure drop
- Filter Element Lifespan... typically 2-5 months
- High Visibility... gradually changes to red from bottom-to-top to know when to change the element

## KC Series...For maximum vapor protection

Hydrocarbon vapors and most organic vapors are targeted for removal by KC Series color change filters. The KC Series uses a transparent column of activated carbon for the adsorption of odors and objectionable tastes. This densely packed element lasts 25 times longer than impregnated carbon filters. A color-change band layer of indicator granules follows that changes from purple to brown as the usable life of the element is exhausted.

### Special Safety Features

Deltech KC & 100 Series filters are fitted with transparent tubes and expanded-metal safety shields. The loose-fitting shields guard against damage from external blows or air system upsets.

The filters may be fitted with metal tubes in place of the transparent tube and safety shield. Metal tubes must be ordered if the filter is expected to be in contact with solvent type paints, phosphate ester-based lubricants, aromatic or chlorinated hydrocarbon solvents, methanol, acetone or other ketones or lacquer solvents. These materials attack the transparent tube and cause it to dissolve or stress crack. Metal tubes are fitted with sight glasses for viewing the color change in the replacement elements.



100 Series filter with insert



## Materials & Construction

100 Series Model KC Series Model	020B	110 KC12, KC13, KC14, KC16	120, 130, 140 KC11	150 KC15
Component	Material			
Tube	Molded Polycarbonate (Lexan) (complete housing)	Extruded Polycarbonate (Lexan)	Double-annealed cast methyl methacrylate	Double-annealed cast methyl methacrylate or Extruded polycarbonate
(Lexan)				
Vessel head, bowl	Heat treated ASTM 356-T6 aircraft-quality aluminum alloy casting			
Downcomer tubes	Electrogalvanized steel			
Tie rods & nuts	Electrogalvanized steel			
Wire mist separator	0.010" aluminum-wire mesh			

## Specifications & Dimensions

### Sizing

To find the maximum flow at pressures other than 100 psig (7 kgf/cm<sup>2</sup>), multiply the flow (from each of the following tables) by the Correction Factor corresponding to the minimum pressure at the inlet of the filter. Do not select filters by pipe size; use flow rate and operating pressure.

Minimum inlet Pressure	psig	20	30	40	60	80	100	120	150	200	250	300
		kgf/cm <sup>2</sup>	1.4	2.1	2.8	4.2	5.6	7.0	8.4	10.6	14.1	17.6
Correction Factor		0.30	0.39	0.48	0.65	0.82	1.00	1.17	1.43	1.87	2.31	2.74

### 100 Series Filter Engineering Data

Models	Flow Capacity scfm	Dimensions inches				Maximum Operating Pressure	Connections inches			Approx. Ship Wt.			
		A	B	C	D		Inlet NPT	Outlet NPT	Drain NPT	Transparent Tube		Metal tube	
										lbs.	kg.	lbs.	kg.
020B	2 1/4	1.3	4.0	-	-	60	1/8	1/8	-	1 1/4	0.57	NA	NA
110	12	2.5	16.0	13.3	2.5	150	1/2	1/2	1/4	4	1.81	8	3.63
120	30	6.0	15.8	0.8	4.0	150	1/2	1/2	1/4	8	3.63	14	6.35
130	50	6.5	16.3	1.0	5.0	150	1	1	1/4	10	4.54	17	7.71
140	100	8.5	18.5	1.0	6.0	150	1	1	1/2	22	9.98	37	16.78
150	190	10.0	19.3	1.3	7.8	150	1 1/2	1 1/2	1/2	28	12.70	47	21.32

### KC Series Filter Engineering Data

Models	Flow Capacity scfm	Dimensions inches				Maximum Operating Pressure	Connections inches			Approx. Ship Wt.			
		A	B	C	D		Inlet NPT	Outlet NPT	Drain NPT	Transparent Tube		Metal tube	
										lbs.	kg.	lbs.	kg.
KC11	12	2.5	16.0	13.3	2.5	150	1/2	1/2	1/4	4	1.81	8	3.63
KC12	30	6.0	15.8	0.8	4.0	150	1/2	1/2	1/4	8	3.63	14	6.35
KC13	50	6.5	16.3	1.0	5.0	150	1	1	1/4	10	4.54	17	7.71
KC14	100	8.5	18.5	1.0	6.0	150	1	1	1/2	23	10.43	38	17.24
KC15	190	10.0	19.3	1.3	7.8	150	1 1/2	1 1/2	1/2	29	13.15	48	21.77
KC16	280	12.5	21.5	1.0	9.3	150	1 1/2	1 1/2	1/2	47	21.32	78	35.38

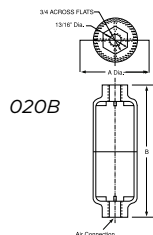

110\*  
KC11\*  
\*Note: Shown  
without sight  
ports for clarity

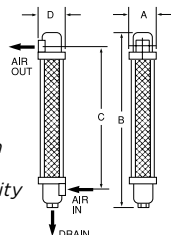

120-160  
KC12-KC16

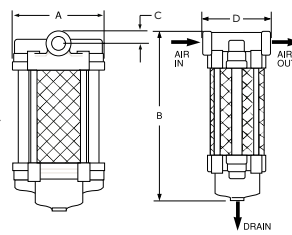

# Specifications and Dimensions

## 810 Series Engineering Data

Models	Std. ASME Stamp <sup>b</sup>	Flow Capacity scfm	Dimensions inches						Maximum Operating Pressure	In-Out	Connections (in.)			Approx. Ship Wt.	
			A	B	C	D	E	F			Relief Valve NPT	Drain (1) NPT	Drain (2) NPT	lbs.	kg.
820	U	1000	22.8	73.0	8.6	61.0	11.4	12.9	150	3 FLG	1 1/2	3/4	3/4	450	204
821	U	1500	24.8	76.0	9.6	63.0	12.4	14.4	150	4 FLG	2	3/4	3/4	575	261
822	U	2000	26.0	82.0	11.0	67.0	13.0	17.3	150	6 FLG	2	3/4	3/4	725	329
823	U	3000	30.0	84.0	12.0	68.0	15.0	18.3	150	6 FLG	2 1/2	3/4	3/4	940	426
824	U	4000	34.0	91.0	14.0	72.4	17.0	21.8	150	8 FLG	3	3/4	3/4	1,175	533
825	U	5000	38.0	94.0	15.0	73.4	19.0	22.8	150	8 FLG	3	3/4	3/4	1,475	669
826	U	7500	42.0	100.0	17.0	78.1	21.0	26.4	150	10 FLG	4	3/4	3/4	1,650	748
827	U	10000	46.0	102.0	17.6	78.6	23.0	27.0	150	10 FLG	4	3/4	3/4	1,850	839
828	U	12500	52.0	110.0	20.0	83.1	26.0	30.4	150	12 FLG	4	3/4	3/4	2,475	1,123
829	U	15000	58.0	114.0	21.6	84.6	29.0	32.0	150	12 FLG	6	3/4	3/4	3,200	1,451

## ME Series Engineering Data

Model	Flow @ 100 psig scfm	Replacement Cartridge	Dimensions		Connections <sup>1</sup>		Maximum Operating Pressure	Weight lbs
			H in.	W in.	Inlet in.	Drain in.		
ME125	125	4001416	40	17	2" FLG	1 NPT	150	194
ME250	250	4001417	40	17	2" FLG	1 NPT	150	200
ME500	500	4001418	52	18	2 1/2" FLG	1 NPT	150	231
ME1100	1,100	4001419	77	26	4" FLG	1 NPT	150	368
ME1500	1,500	4001421	85	27	4" FLG	1 NPT	150	410
ME2100	2,100	4001422	94	33	4" FLG	1 NPT	150	735
ME2400	2,400	4001423	94	33	4" FLG	1 NPT	150	751
ME3000	3,000	4001424	94	33	4" FLG	1 NPT	150	767

Maximum working pressure: 150 psig (10.5 kgf/cm<sup>2</sup>), Maximum operating temperature: 150°F (66°C)

<sup>1</sup> Consult factory for BSP or DN flanges

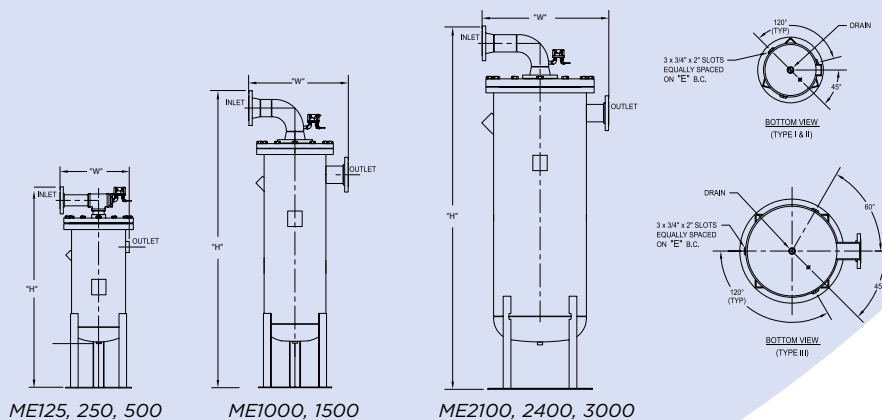
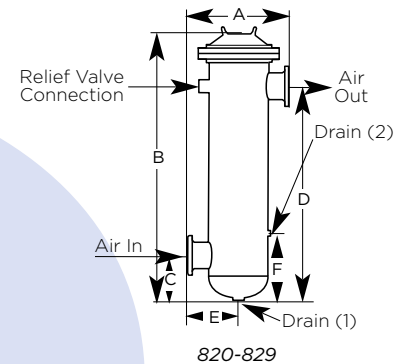

## DTA Series Engineering Data

Model Number	Max. Flow @ 100 psig scfm	MWP' @ 450°F psig	In/Out Connection <sup>2</sup>	Dimensions in.		Weight lbs
				W	H	
DTA100	100	250	1" NPT	4.25	14.31	13
DTA200	200	250	1" NPT	4.25	23.81	19
DTA400	400	165	3" NPT	10.25	39.56	95
DTA600	600	165	3" NPT	10.25	39.56	95
DTA1200	1,200	165	3" NPT	16.00	41.44	159
DTA1800	1,800	165	3" NPT	16.25	43.25	219
DTA2400	2,400	165	4" ANSI Flange	20.00	54.69	236
DTA3000	3,000	165	4" ANSI Flange	20.00	54.69	239
DTA4800	4,800	165	6" ANSI Flange	24.00	53.00	319
DTA6600	6,600	165	6" ANSI Flange	28.00	62.00	548
DTA8400	8,400	165	6" ANSI Flange	28.00	62.00	548
DTA11400	11,400	165	8" ANSI Flange	33.00	68.19	772

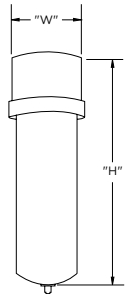

- <sup>1</sup> Units with higher MWP are available; contact factory. Model DTA1200 and larger are ASME code constructed and stamped. Pressure drop: At rated flow conditions pressure drop will be less than 1 psid (0.07 kgf/cm<sup>2</sup>). Pressure drop will increase only as the filter cartridges become loaded with solid particles. Filter cartridge replacement: Filter cartridges should be replaced when pressure drop across the cartridge exceeds 10 psid (0.7 kgf/cm<sup>2</sup>). Maximum temperature: 450°F (232°C)
- <sup>2</sup> BSP connections and DIN Flanges are available.

## DF Series Engineering Data

Replacement Model	Capacity scfm	Connections NPT/ ANSI Flg.	Standard Features Filter Grades						Max Pressure and Temp Manual Drain With		Dimensions			Element			
			E	D	A,B,C	Y	Z	Drain	D	H in	W in	Weight lb	Model	Qty.			
<b>Modular Type Housings</b>																	
DF20(Grade)(Connection)(Features)	20	3 - 3/8" NPTF or 4 - 1/2" NPTF	D	D, P	D, P	P	N	O	300 psig	250 psig	150°F	150°F	8.15	4.13	4.2	FE20(Grade)	1
DF35(Grade)(Connection)(Features)	35												11.05	4.13	8.1	FE35(Grade)	
DF60(Grade)(Connection)(Features)	60												13.40	4.13	8.5	FE60(Grade)	
DF100(Grade)(Connection)(Features)	100	6 - 3/4" NPTF or 8 - 1" NPTF	D	D, G	D, G	G	O	N	150°F	150°F	15.32	5.25	6.3	FE100(Grade)			
DF170(Grade)(Connection)(Features)	170										19.57	5.25	6.9	FE170(Grade)			
DF250(Grade)(Connection)(Features)	250	8 - 1" NPTF or 10 - 1-1/4" NPTF or 12 - 1-1/2" NPTF	(1)	G	D, G	G	O	N	150°F	150°F	22.80	6.44	10.2	FE250(Grade)			
DF375(Grade)(Connection)(Features)	375										27.29	6.44	11.3	FE375(Grade)			
DF485(Grade)(Connection)(Features)	485	16 - 2" NPTF or 20 - 2-1/2" NPTF	(1)	G	D, G	G	O	N	150°F	150°F	31.08	7.63	28	FE485(Grade)			
DF625(Grade)(Connection)(Features)	625										36.83	7.63	33	FE625(Grade)			
DF780(Grade)(Connection)(Features)	780	20 - 1/2" NPTF	(1)	G	D, G	G	O	N	150°F	150°F	42.96	7.63	38	FE780(Grade)			
<b>ASME Pressure Vessels</b>																	
DF1000(Grade)(Connection)(Features)	1,000	24 - 3" NPTM	(1)	G	(1)	G	O	N	225 psig	225 psig	150°F	150°F	48.00	16.00	91	FE1000(Grade)	2
DF1250(Grade)(Connection)(Features)	1,250												48.00	16.00	91	FE1250(Grade)	
DF1875(Grade)(Connection)(Features)	1,875	24 - 3" NPTM	(1)	G	(1)	G	O	N	225 psig	225 psig	150°F	150°F	49.00	16.25	120	FE1875(Grade)	
DF2500(Grade)(Connection)(Features)	2,500	4F - 4" ANSI Flange											52.25	20.00	179	FE2500(Grade)	
DF3125(Grade)(Connection)(Features)	3,125	6F - 6" ANSI Flange	(1)	G	(1)	G	O	N	225 psig	225 psig	150°F	150°F	52.25	20.00	182	FE3125(Grade)	
DF5000(Grade)(Connection)(Features)	5,000												54.63	24.00	271	FE5000(Grade)	
DF6875(Grade)(Connection)(Features)	6,875	6F - 6" ANSI Flange	(1)	G	(1)	G	O	N	225 psig	225 psig	150°F	150°F	62.56	28.00	518	FE6875(Grade)	
DF8750(Grade)(Connection)(Features)	8,750												62.56	28.00	527	FE8750(Grade)	
DF11875(Grade)(Connection)(Features)	11,875	8F - 8" ANSI Flange	(1)	G	(1)	G	O	N	225 psig	225 psig	150°F	150°F	69.13	33.00	709	FE11875(Grade)	
DF16250(Grade)(Connection)(Features)	16,250	8F - 8" ANSI Flange											67.94	39.00	918	FE16250(Grade)	
DF21250(Grade)(Connection)(Features)	21,250	10F - 10" ANSI Flange	(1)	G	(1)	G	O	N	225 psig	225 psig	150°F	150°F	70.94	45.88	1412	FE21250(Grade)	

### Filter Grades

- A - Maximum Efficiency Oil Removal Filter (0.0008 ppm)
- B - High Efficiency Oil Removal Filter (0.008 ppm)
- C - Air Line Filter (1 micron)
- D - Separator/Filter (3 micron and bulk liquid)
- E - Mechanical Separator (bulk liquid)
- Y - Dry Desiccant Afterfilter (1 micron)
- Z - Oil Vapor Removal Filter (activated carbon)

### Features:

- D - Internal Automatic Drain Mechanism
- P - Differential Pressure Slide Indicator
- G - Differential Pressure Gauge Indicator
- S - Corrosion Proof Stainless Steel element
- M - Pressure Monitor

- (1) Drain plugs standard. Externally mounted automatic drains are available.
- (2) Time-based Pressure Monitor recommended

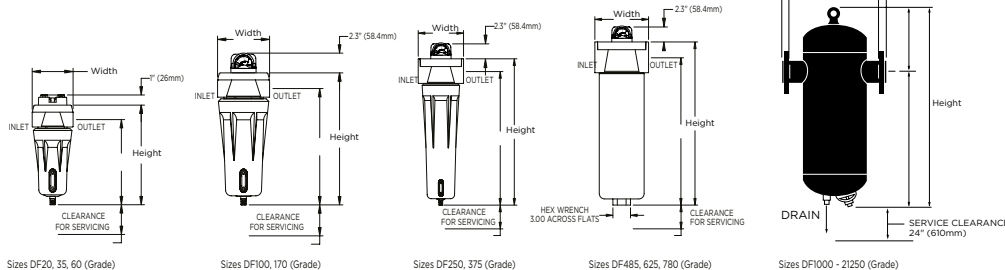



# Compressed Air Filtration Technologies

## DF Series | 810 Series | DTA Series | ME Series | Color-Change

Design features, materials of construction and dimensional data, as described in this bulletin, are provided for your information only and should not be relied upon unless confirmed in writing.

Please contact your local sales representative for product availability in your region.



### **Deltech Headquarters**

4647 SW 40th Avenue  
Ocala, Florida 34474-5788 U.S.A.

**Tel.:** (724) 745-1555

**Fax:** (724) 745-6040

[deltechair.com](http://deltechair.com)