

DATA SHEET

**U 4.630**

# ROTARY VANE- VACUUM PUMPS

oil-lubricated  
air-cooled

---

**MAKE IT BECKER.**



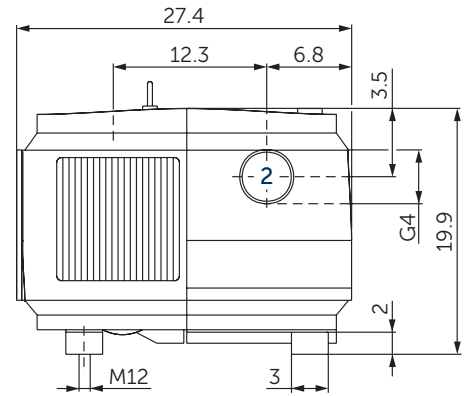
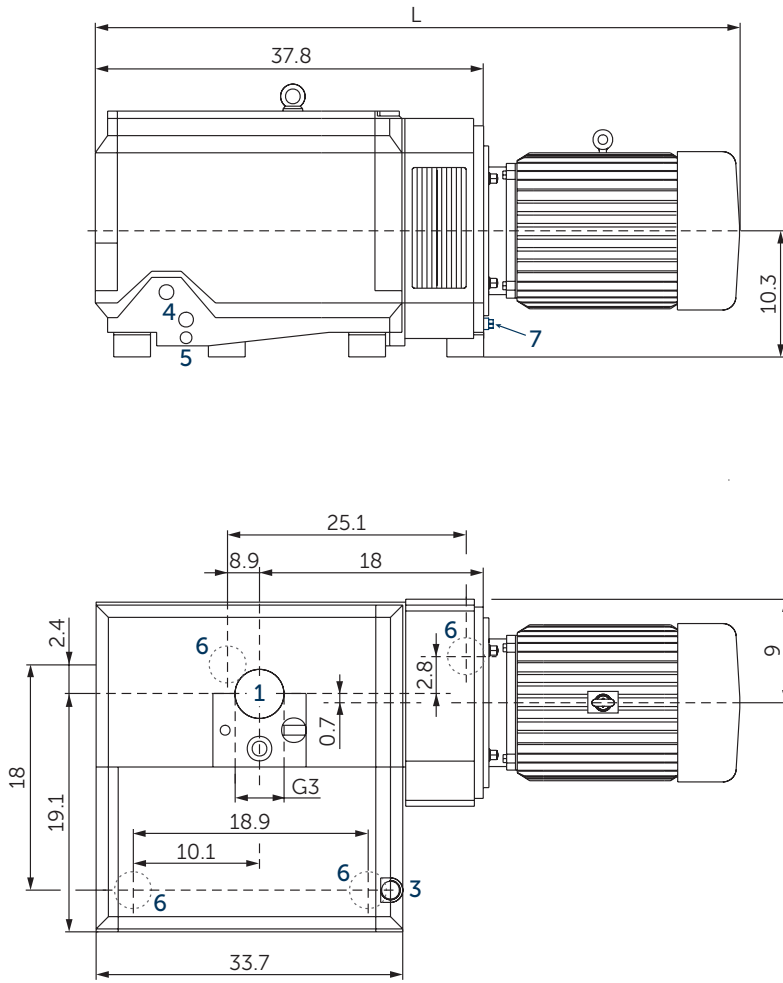

- 1 Vacuum connection (G3)
- 2 Exhaust air connection (G4)
- 3 Oil filler cap
- 4 Oil sight glas
- 5 Screw plug for oil drain
- 6 Rubber buffer position
- 7 PT100
  - incl. non-return valve and oil separator
  - The motor illustration may vary
  - Dimensions in inch

	Nominal capacity		Vacuum		Emission sound pressure level <sup>1)</sup>		Weight w/o motor	Oil <sup>2)</sup>
	CFM		Torr		dB(A)			
	50 Hz	60 Hz	50 Hz	60 Hz	50 Hz	60 Hz	lbs	U.S. gal.
<b>U 4.630 SA/K</b>	366	430	2.25	2.25	80	83	816	3.7
<b>U 4.630 F/K</b>	366	430	0.375	0.375	80	83	816	3.7

<sup>1)</sup> DIN EN ISO 3744 (KpA = 3 dB(A)) interval of 39.4 inch, at medium load, both connection sides piped

<sup>2)</sup> Becker Synthetic Oil, Becker Premium Synthetic Oil (PAO) and Becker Food Grade Vacuum Pump Oil

3~ Motors												L	
#	50 Hz					60 Hz				Version	Weight lbs	inch	
	hp	V	rpm	A	hp	V	rpm	A					
01	20.1	Δ400	IE3	985	33.4	24.1	Δ460	IE3	1183	33.7	UL (E235514) • CSA CC329B IP 55 • ISO F • bimetal	432.2	60.9
							Δ400						
02						24.1	YY230/Y460	IE3	1183	69.1/34.6	UL (E235514) • CSA CC329B IP 55 • ISO F • bimetal	358.3	60.9
							YY208						
03	20.1	Δ200/Y350	IE3	987	68.6/39.6	24.1	Δ200/Y380-400	IE3	1185	69.7/40.2-39.6	UL (E235514) • CSA CC329B IP 55 • ISO F • bimetal	359.4	60.9
							Δ200/Y350	IE3	1180	73.1/42.2			
04						24.1	Δ400/Y490	IE3	1185	38.9/22.4	UL (E235514) • CSA CC329B IP 55 • ISO F • bimetal	434.4	60.9

- Type plate data on current consumption and rotation speed of the motors may vary. Tolerance -1.5/+2% in each case.

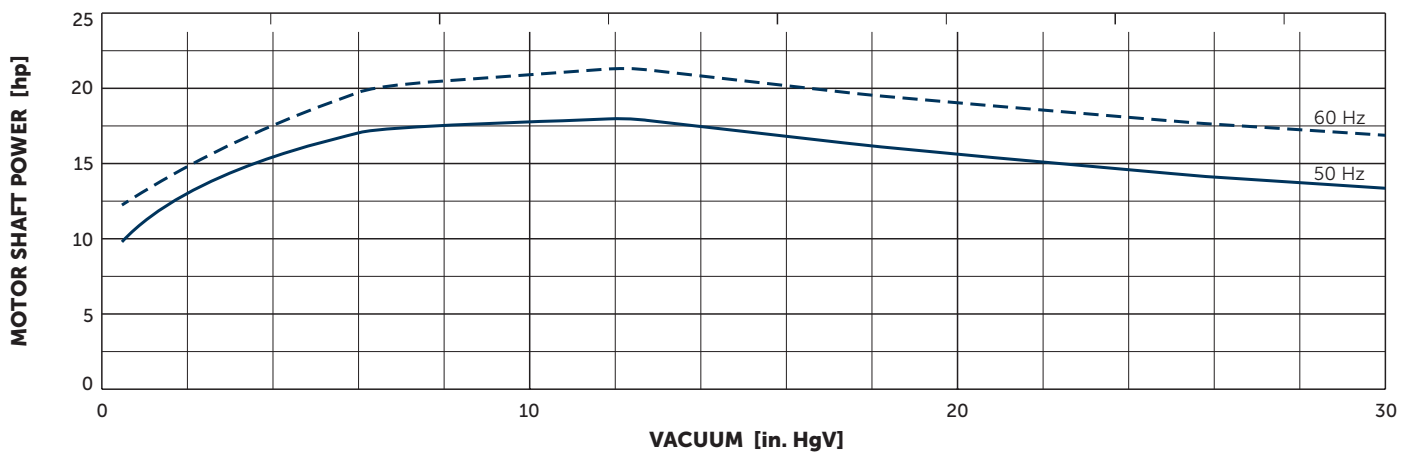
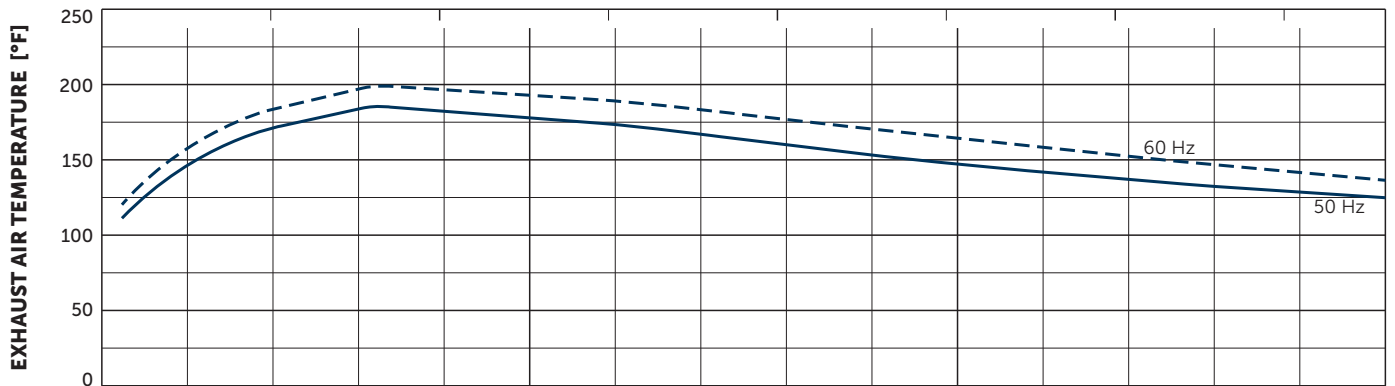
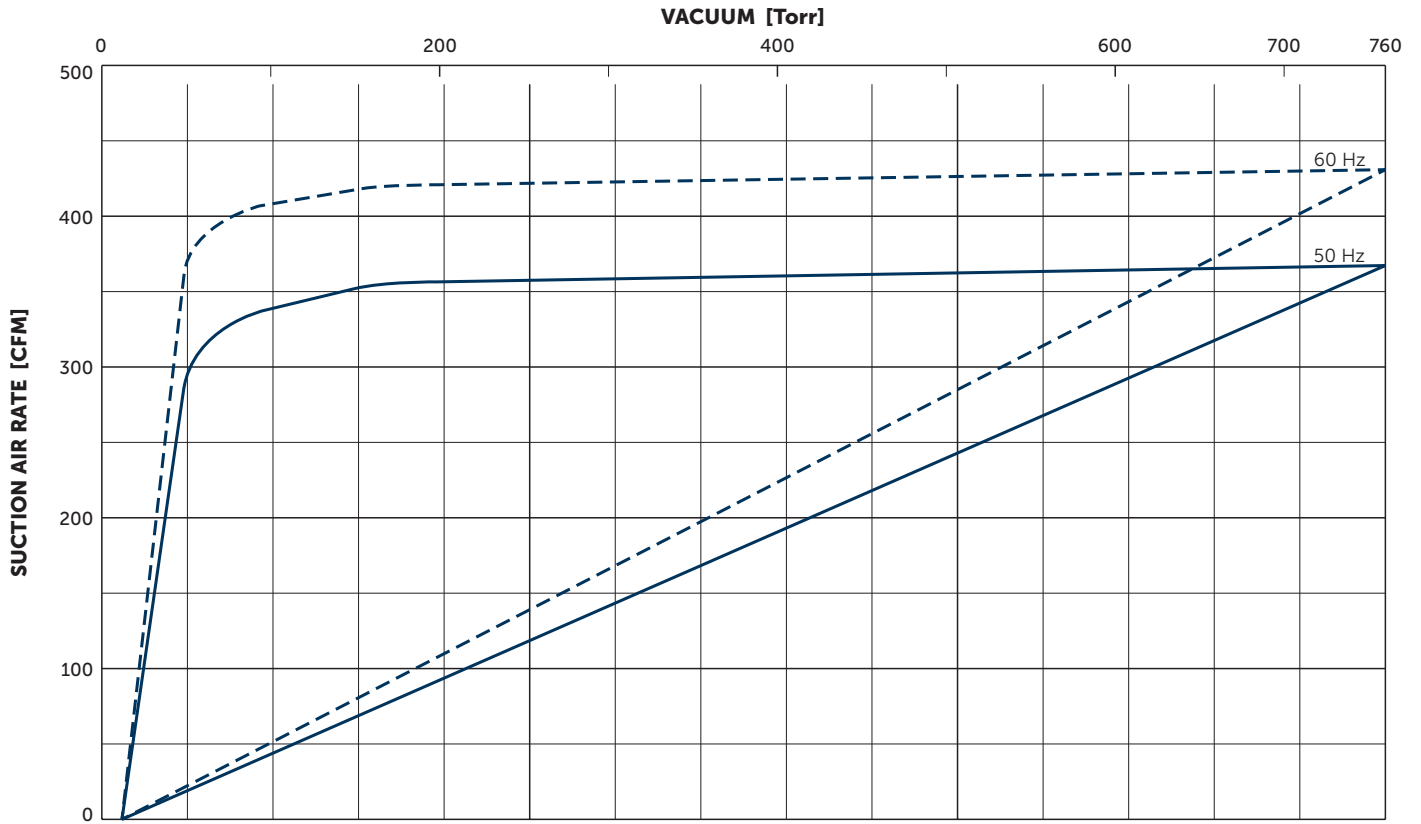

Suction air rate refers to the intake pressure  
 Reference data (atmosphere): 0 In. HgV / 760 Torr, 68°F; Tolerance: ±5%

## + ACCESSORIES

- Gas ballast valve ST 626-0-4 (no. 76870499626)
- Temperature trigger unit for monitoring the pump temperature with the use of the integrated temperature sensor PT100<sup>1)</sup>
- Temperature monitor TW for monitoring the oil temperature<sup>1)</sup>
- Oil level switch ST 682-0-2 for monitoring the oil level<sup>1)</sup>
- Oil bath heating and thermostat
- Maintenance indicator ST 691-0-1 for oil separating elements (no. 91680099691)
- Oil-to-water heat exchanger
- External suction filter, e.g. FV 540<sup>1)</sup>
- Oil: Becker Lube M100 mineral, S100 synthetic and SL100 food

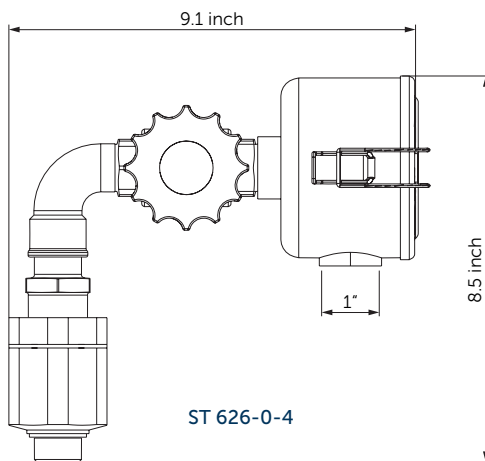

Temperature trigger unit



Temperature monitor TW



Oil level switch ST 682-0-2



Maintenance indicator ST 691-0-1



Example for an external suction filter

<sup>1)</sup> See separate data sheet

- Combination options on request



**MAKE IT BECKER.**