

DATA SHEET

U 4.400

ROTARY VANE- VACUUM PUMPS

oil-lubricated
air-cooled

MAKE IT BECKER.



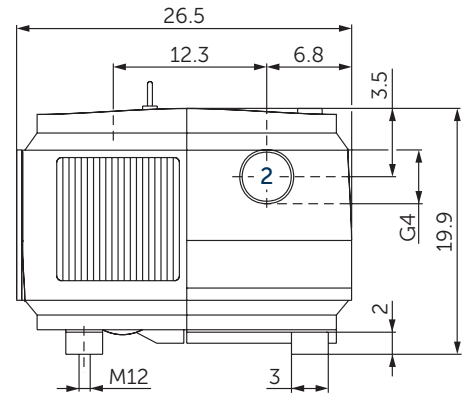
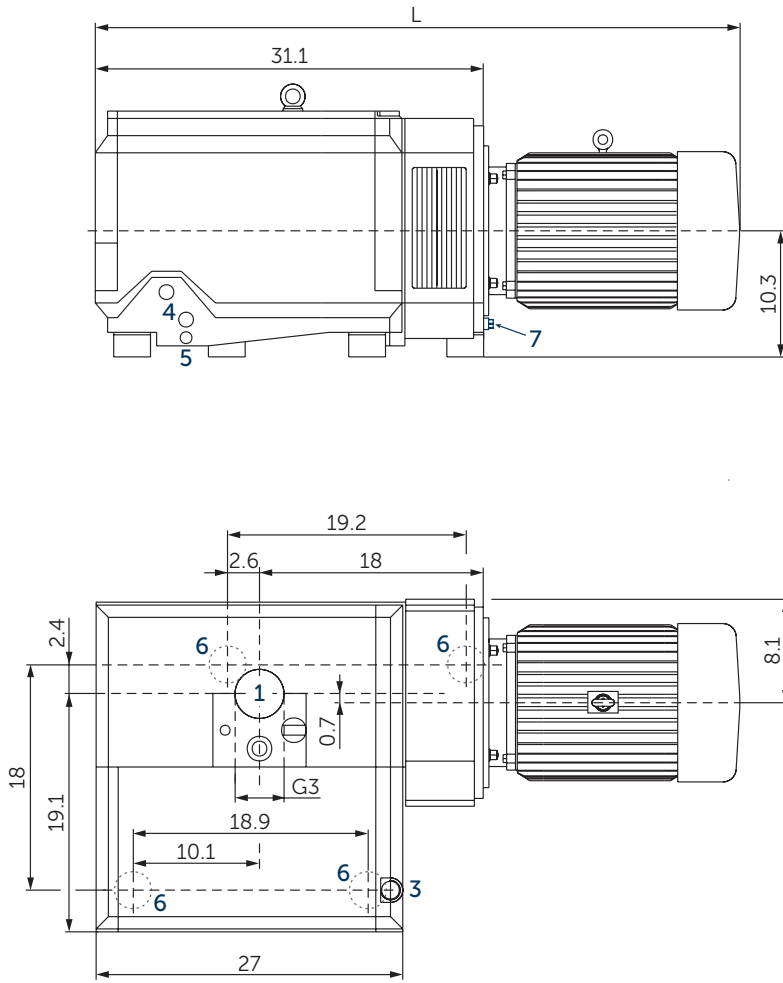

- 1 Vacuum connection (G3)
- 2 Exhaust air connection (G4)
- 3 Oil filler cap
- 4 Oil sight glas
- 5 Screw plug for oil drain
- 6 Rubber buffer position
- 7 PT100
 - incl. non-return valve and oil separator
 - The motor illustration may vary
 - Dimensions in inch

	Nominal capacity		Vacuum		Emission sound pressure level ¹⁾		Weight w/o motor	Oil ²⁾
	CFM		Torr		dB(A)			
	50 Hz	60 Hz	50 Hz	60 Hz	50 Hz	60 Hz	lbs	U.S. gal.
U 4.400 SA/K	256	299	2.25	2.25	78	81	613	3.7
U 4.400 F/K	256	299	0.375	0.375	78	81	613	3.7

¹⁾ DIN EN ISO 3744 (KpA = 3 dB(A)) interval of 39.4 inch, at medium load, both connection sides piped

²⁾ Becker Synthetic Oil, Becker Premium Synthetic Oil (PAO) and Becker Food Grade Vacuum Pump Oil

3~ Motors												L	
#	50 Hz				60 Hz				Version	Weight lbs	inch		
	hp	V	rpm	A	hp	V	rpm	A					
01	14.8	Δ230/Y400	IE3	987	43.5/25.1	17.7	Δ265/Y460	IE3	1186	43.8/25.3	IP 55 • ISO F • PTC	359.4	54.2
							Δ230/Y400		1180	46.9/27.1			
02	14.8	Δ230/Y400	IE3	987	43.5/25.1	17.7	Δ265/Y460	IE3	1186	43.8/25.3	UL (E235514) • CSA CC329B IP 55 • ISO F • bimetal	359.4	54.2
							Δ230/Y400		1180	46.9/27.1			
03	14.8	Δ400	IE3	987	24.9	17.7	Δ460	IE3	1185	22.1/11.1	IP 55 • ISO F • bimetal	359.4	54.2
							Δ400		1180	23.3			
04	14.8	Δ400	IE3	987	24.9	17.7	Δ460	IE3	1185	25.0	UL (E235514) • CSA CC329B IP 55 • ISO F • bimetal	359.4	54.2
							Δ400		1180	27.3			
05						17.7	YY230/Y460	IE3	1185	50.6/25.3	UL (E235514) • CSA CC329B IP 55 • ISO F • bimetal	358.3	54.2
							YY208		1180	52.9			
06	14.8	Δ200/Y350		985	45.9/26.5	17.7	Δ200/Y380–400	IE3	1185	49.0/28.3–27.2	UL (E235514) • CSA CC329B IP 55 • ISO F • bimetal	359.4	53.9
							Δ200/Y350		1177	52.8/30.5			
07						17.7	Δ400/Y490	IE3	1185	27.8/15.9	UL (E235514) • CSA CC329B IP 55 • ISO F • bimetal	366.0	54.2

• Current consumption and rotation speed may vary. Tolerance in each case -1.5/+2%

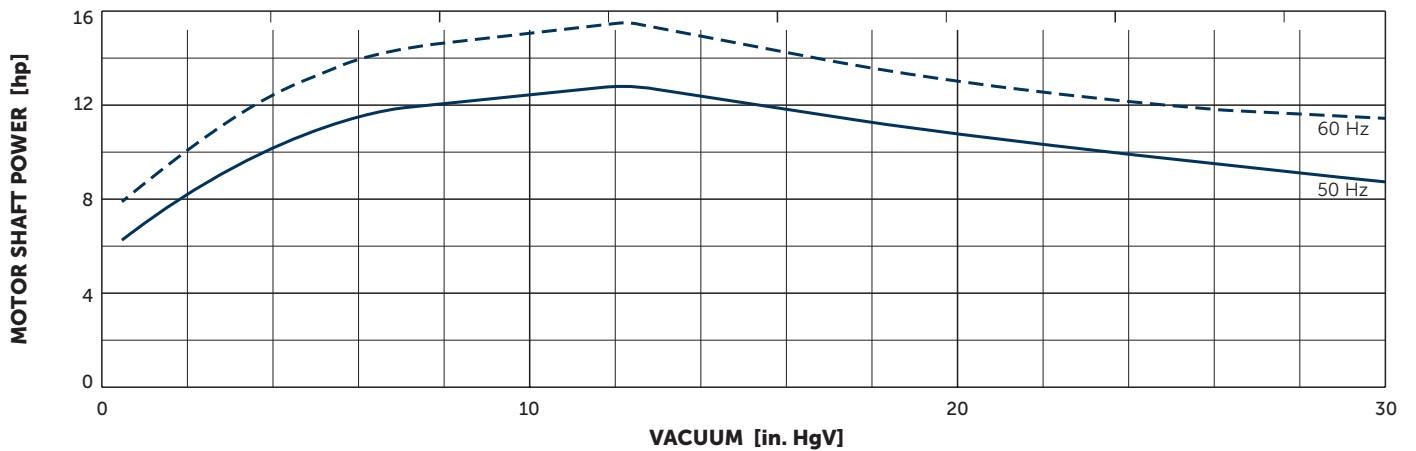
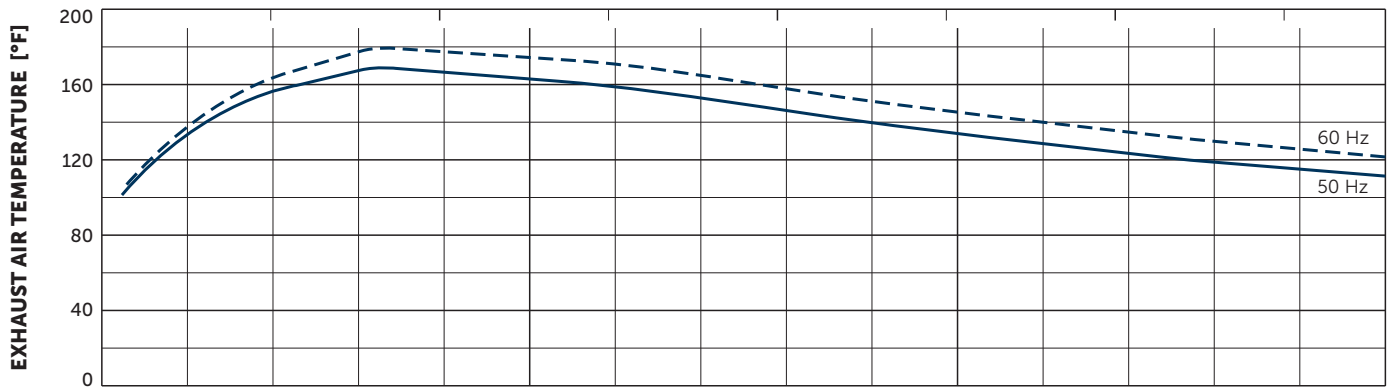
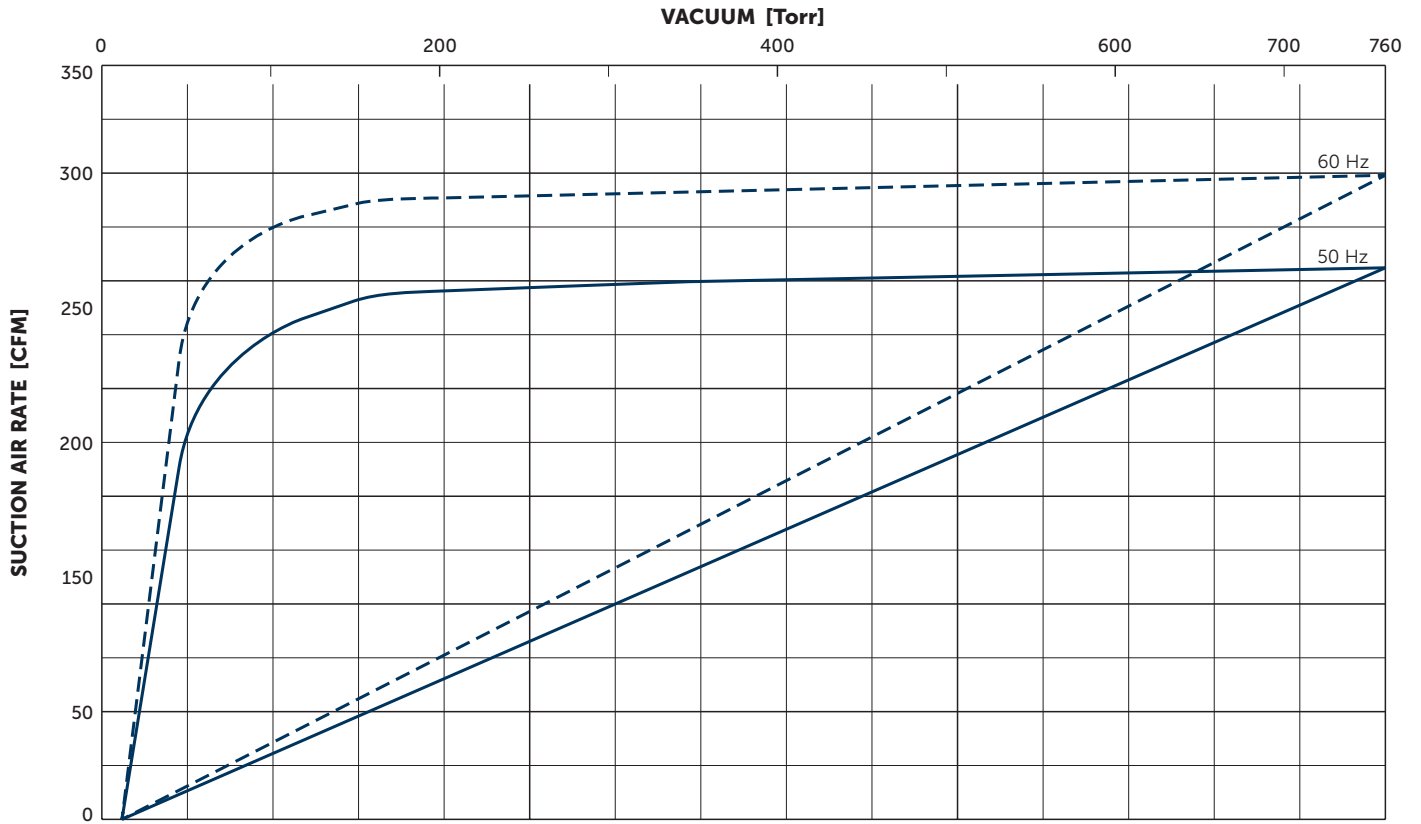

Suction air rate refers to the intake pressure
 Reference data (atmosphere): 0 In. HgV / 760 Torr, 68°F; Tolerance: ±5%

+ ACCESSORIES

- Gas ballast valve ST 626-0-4 (no. 76870499626)
- Temperature trigger unit for monitoring the pump temperature with the use of the integrated temperature sensor PT100¹⁾
- Temperature monitor TW for monitoring the oil temperature¹⁾
- Oil level switch ST 682-0-2 for monitoring the oil level¹⁾
- Oil bath heating and thermostat
- Maintenance indicator ST 691-0-1 for oil separating elements (no. 91680099691)
- Oil-to-water heat exchanger
- External suction filter, e.g. FV 540¹⁾
- Oil: Becker Lube M100 mineral, S100 synthetic and SL100 food

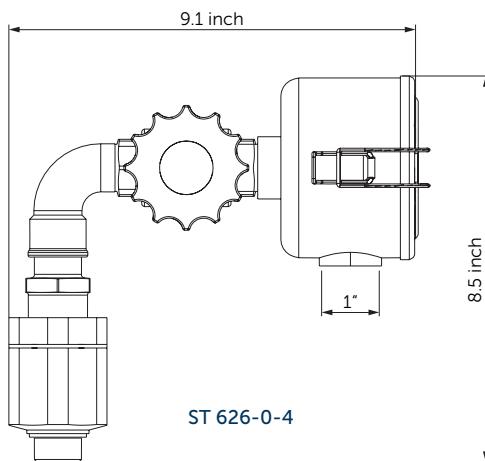

Temperature
trigger unit



Temperature monitor
TW



Oil level switch
ST 682-0-2



Maintenance indicator
ST 691-0-1



Example for an
external suction filter

¹⁾ See separate data sheet

- Combination options on request



MAKE IT BECKER.