

Less Waste Maximum Efficiency



What is Optiflo?

Simply stated, Optiflo is an advanced technology designed to optimize your compressed air usage. Every air system, no matter how good, has leaks. When reducing an air system's working pressure, the volume of air lost through leakage is dramatically reduced. The reduction in lost air volume directly relates to power savings on the running of your air compressor and increases your bottom line.

Even tools benefit. Air tools are designed to work at specific pressures, so ensuring the correct pressure to your tools will optimize their performance, increase life and reduce maintenance, all in addition to preventing wasted energy.

Installing an Optiflo in your system will not only provide considerable power savings but also increase the life expectancy of your compressor and radically reduce maintenance costs. Minimizing lost air volume will reduce the amount of time your compressor has to run. The less it runs the longer its life expectancy and the less maintenance it will require.

- > **Significantly Reduce Energy**
- > **Improve Productivity**
- > **Enhance Compressor Life**
- > **Minimize Maintenance Costs**

Optiflo 10/7 Equation

Every 10 psi in plant pressure reduction will gain you 7% energy savings. Installing an Optiflo in conjunction with suitable storage, allows compressed air to be stored at a high pressure while delivering consistent, low-pressure air to the balance of the system.

Typical Compressor Usage

15 HP (11kw) compressor running 3000 hours per year at 10¢ per KW = \$3,300 annual power cost.

Savings with Optiflo



Optiflo Features:

- Nitrile seals for high level of chemical resistance.
- Balanced valve design is the most robust available and provides immediate response to changes in air demands.
- NPT threads to connect easily to new or existing pipe systems.
- Glycol filled, stainless steel dual gauge design for easy reference of pressure at inlet and outlet.
- Unit can be fixed to wall or secured directly to the piping system.
- Powder coated steel chassis for enhanced durability.
- Tamper proof dial centrally located for quick adjustment and easy calibration.
- Unit can be ordered for left to right or right to left flow to meet your install needs.
- Compatible with both rotary and reciprocating compressor technology.

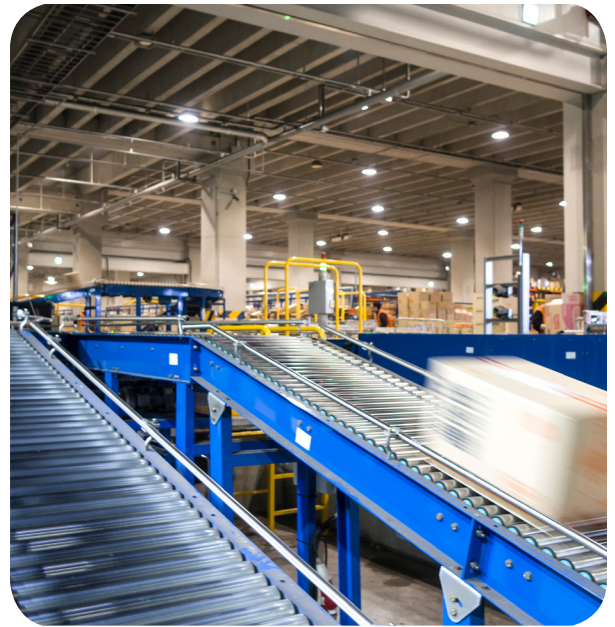

Typical Optiflo System

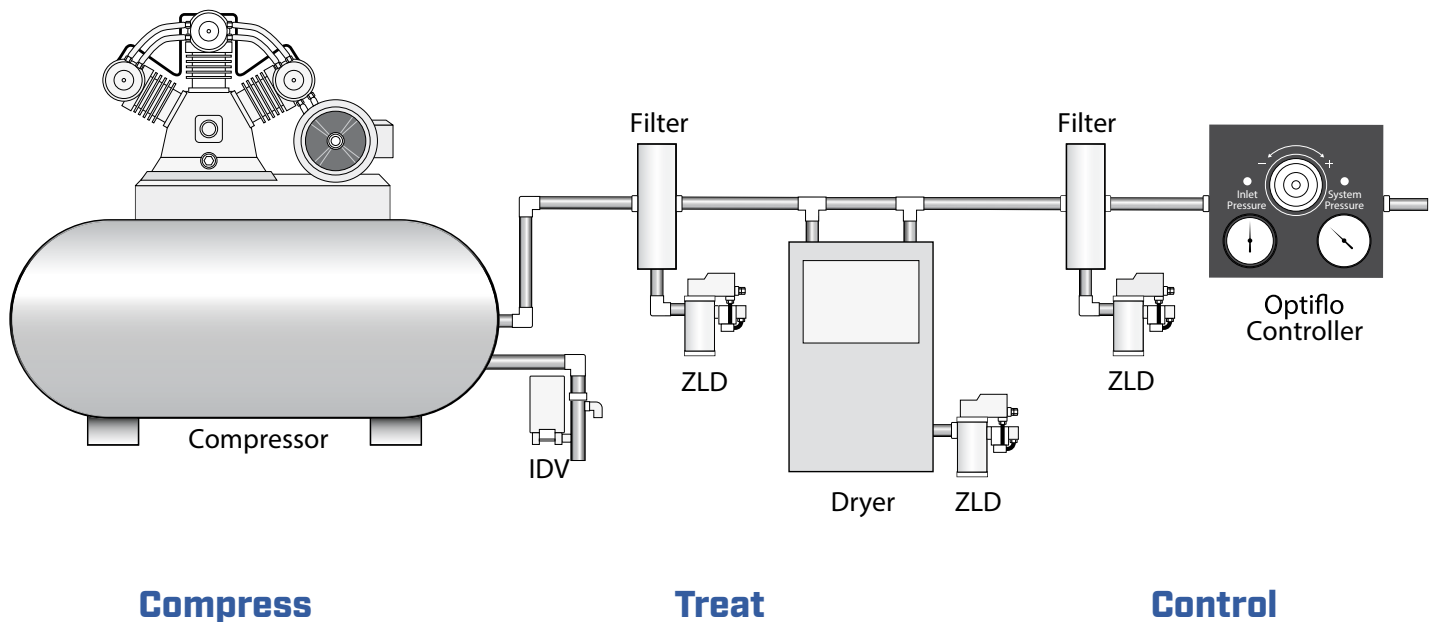

Optiflo Technical Data

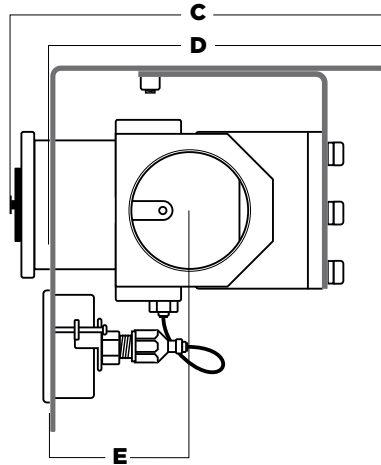
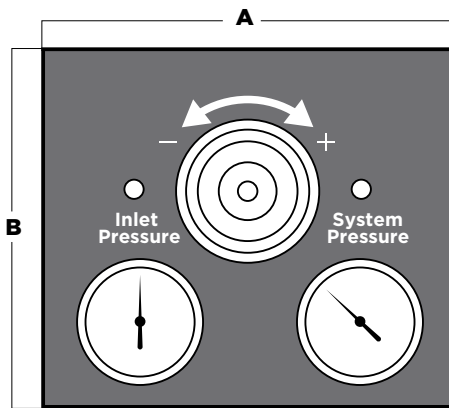

Inlet Size	Max Flow	A	B	C	D	E	Weight
1/2"	75 scfm	8.11"	7.28"	8.57"	7.36"	1.89"	8.4lbs
1"	200 scfm					2.21"	10.45 lbs
2"	1000 scfm					2.78"	14.65 lbs

Optiflo color choices to match your system



Inlet Size	Frame Color	Max Flow	Max Inlet Pressure	Control Range	Temp Range	Sensitivity	Repeatability
1/2"	Green	75 scfm	300 psig	0-160 psig	-4°F to +176°F	0.2% of full span	±0.5% of full span
	Blue						
	Black						
1"	Green	200 scfm	300 psig	0-160 psig	-4°F to +176°F	0.2% of full span	±0.5% of full span
	Blue						
	Black						
2"	Green	1000 scfm	300 psig	0-160 psig	-4°F to +176°F	0.2% of full span	±0.5% of full span
	Blue						
	Black						

Optiflo - TruLink



BLACK CHASSIS

Black Chassis, 75 cfm, 1/2" NPT Left to Right Flow	TP-75-BLK-LR
Black Chassis, 200 cfm, 1" NPT Left to Right Flow	TP-200-BLK-LR
Black Chassis, 1000 cfm, 2" NPT Left to Right Flow	TP-1000-BLK-LR
Black Chassis, 75 cfm, 1/2" NPT Right to Left Flow	TP-75-BLK-RL
Black Chassis, 200 cfm, 1" NPT Right to Left Flow	TP-200-BLK-RL
Black Chassis, 1000 cfm, 2" NPT Right to Left Flow	TP-1000-BLK-RL



GREEN CHASSIS

Green Chassis, 75 cfm, 1/2" NPT Left to Right Flow	TP-75-GRN-LR
Green Chassis, 200 cfm, 1" NPT Left to Right Flow	TP-200-GRN-LR
Green Chassis, 1000 cfm, 2" NPT Left to Right Flow	TP-1000-GRN-LR
Green Chassis, 75 cfm, 1/2" NPT Right to Left Flow	TP-75-GRN-RL
Green Chassis, 200 cfm, 1" NPT Right to Left Flow	TP-200-GRN-RL
Green Chassis, 1000 cfm, 2" NPT Right to Left Flow	TP-1000-GRN-RL



BLUE CHASSIS

Blue Chassis, 75 cfm, 1/2" NPT Left to Right Flow	TP-75-BLU-LR
Blue Chassis, 200 cfm, 1" NPT Left to Right Flow	TP-200-BLU-LR
Blue Chassis, 1000 cfm, 2" NPT Left to Right Flow	TP-1000-BLU-LR
Blue Chassis, 75 cfm, 1/2" NPT Right to Left Flow	TP-75-BLU-RL
Blue Chassis, 200 cfm, 1" NPT Right to Left Flow	TP-200-BLU-RL
Blue Chassis, 1000 cfm, 2" NPT Right to Left Flow	TP-1000-BLU-RL