



VIPER 
DIESEL

 AIR COMPRESSOR

Smart, Fuel Efficient, Powerful and Dependable Air Power!

With the Vanair® Viper™ Diesel you get all the air power you need to get the job done at half the cost of tow behinds or cross mounts. Engineered with smart technology to provide automatic variable speed control for fuel savings, the Viper™ is perfect for running 90 Lb. jackhammers, operating up to 4" piercing tools and blowing out irrigation systems. Designed with a simple push start control panel, the Viper™ is compact enough to fit into even the smallest pickup truck bed.

SPECIFICATIONS			
Model	D60	D70	D80
Capacity (CFM)	60	70	80 <small>(48 CFM at Idle)</small>
Air (PSI)	150	125 <small>(100 PSI at altitudes of 3500+ Ft.)</small>	100
Engine (RPM)	3600	3600	3600
Engine (HP)	24.8	24.8	24.8
Fuel Capacity	9 Gallon	9 Gallon	9 Gallon

Viper™ Diesel Unit Dimensions with fittings (In.):
 48L x 21W x 33H | Dry Weight (Lbs.): 735



VIPER

DIESEL

FEATURES

- Automatic Variable Speed Control
Reduces Fuel Consumption
- 60 AMP Alternator
- Integrated Battery
- Cooling Baffle Ensures Proper Ventilation,
Protects Machine from Debris and
Reduces Noise
- Extra DC Power for Air After Cooler Use
- Sized to Fit Behind the Cab or Side Pack

AIR COMPRESSOR

- Lifetime Warranty on Air End
- Direct Drive - No Belts
- Oil Injected Rotary Screw Encapsulated
Air End

ENGINE

- Auto Shut Off and Start for Fuel Savings
- Kubota® Tier 4 Certified
- Diesel
- Liquid Cooled
- 3 Cylinder
- 24.8 HP
- 9 Gallon Fuel Tank
- Glow Plugs

INSTRUMENTATION

- Conveniently Located Electronic
Easy-To-Start Instrumentation Panel
- Features an Hour Meter, Pressure and
Temperature Readout, Fuel Gauge and
Engine RPM

CANOPY

- Powder-Coated, Galvannealed Sheet
Metal Enclosure
- Lifting Bail

MAINTENANCE

- Easy Service Access - Removable Front
Panel and Hinged Top for Serviceability
- Features an Hour Meter, Pressure and
Spin-On Air-To-Oil Separating Element for
Easy Maintenance

SAFETY EQUIPMENT

- High-Temperature Shutdown Compressor
and Engine
- Low Engine Oil Pressure Shutdown
- Air Pressure-Relief Safety Valve
- Minimum Pressure Valve
- Automatic Blowdown On Shutdown
- Oil Fill Plug Safety Relief
- High Pressure Shutdown for Compressor

OPTIONS/ACCESSORIES

- Service/Control Line Moisture Separators
- Filter/Lubricator/Regulator (FLR)
- Air Hoses, Hose Reels, and Fittings
- OSHA Safety Valve (Velocity Fuse)
- Tool Oiler/Lubricator
- Cold Weather Package to Prevent
Freeze-Ups
- Remote Instrument Panel
- Air After Cooler
- Remote Fuel Tank Option
- Maintenance Kits
- DOT Trailer
- Hand Cart

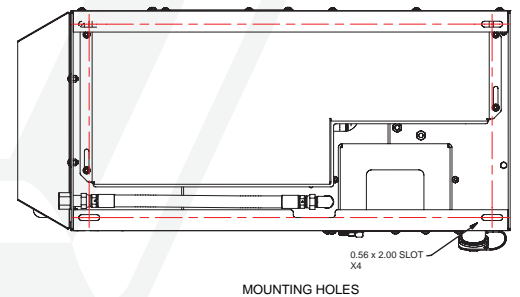
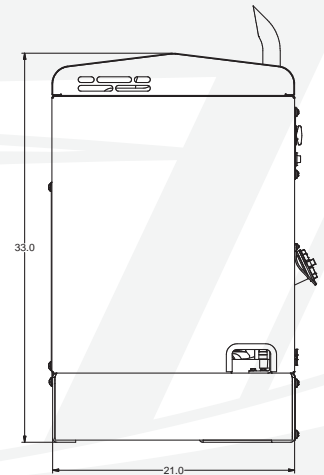
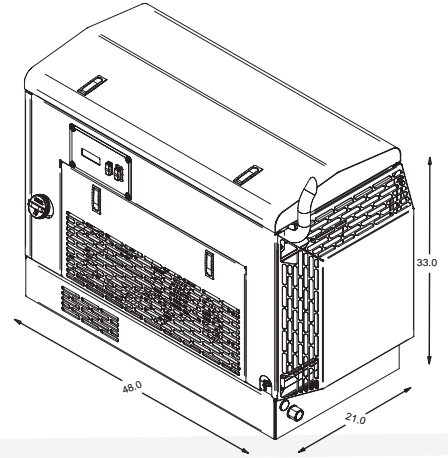

Vanair reserves the right to make changes in engineering, design, and specifications; add improvements; or discontinue manufacturing at any time without notice or obligation. Vanair, the Vanair logo and MOBILE POWER SOLUTIONS are registered trademarks or trademarks of Vanair Manufacturing, Inc., Michigan City, IN, USA. © 2021 All Rights Reserved.

