

# StarlettePlus-E Refrigeration Dryers

SPS 10 - 250  
60Hz - UL Listed



Untreated compressed air is wet. 100% saturated as it leaves the compressor aftercooler, water vapor in the compressed air cools as it enters the air receiver and distribution piping, resulting in the formation of condensed liquid water and water aerosols. Wet compressed air leads to corrosion, the growth of micro-organisms and the formation of oily, acidic compressor condensate.

For a manufacturing facility reliant on compressed air for automation, these contaminants can directly impact safety, productivity and efficiency.

Compressed air treatment is essential and for non-critical uses of compressed air, the refrigeration dryer is an ideal choice.

## Refrigeration Dryers

Refrigeration dryers use a closed loop cooling system to lower the temperature of the compressed air to just above freezing, causing condensation of water vapor.

Most of the condensed liquid is then removed by an integral water separator and drained away. Prior to leaving the dryer, the compressed air is re-heated by the incoming compressed air to prevent condensation on the outside of the downstream distribution piping.

Designed with environmentally friendly, low Global Warming Potential (GWP) refrigerant gas, R513A, Parker's SPS Series Refrigeration Dryers are the best choice for quality, performance and the environment.



## Advantages

- Parker StarlettePlus-E refrigeration dryers are developed around a state-of-the-art aluminum heat exchanger (E-Pack), with a patent pending all-in-one design.
- The E-Pack heat exchanger is designed with a large air/air heat exchanger to pre-cool the incoming hot, saturated compressed air and therefore reduce energy consumption.
- The highly efficient E-Pack design results in a refrigeration circuit that uses a smaller volume of refrigerant than other comparable dryers and offers one of the lowest absorbed powers in the industry.
- The E-Pack design utilizes low pressure drop, cross flow heat exchangers to reduce operational costs.
- The E-pack heat exchanger includes a high efficiency stainless steel demister separator for liquid removal over all operating conditions.
- Environmentally friendly, low Global Warming Potential (GWP) refrigerant gas, R513A, on all units.
- All models are equipped as standard with a digital controller that includes an indication of compressed air temperature, volt free alarm contact, service reminder and integral timed drain control.
- All StarlettePlus-E models are ETL listed.
- Optional Energy Saving (ES) models (SPS075 – SPS0250) saves energy by matching power consumption to compressed air demand. The ES models adjust to partial load conditions by allowing the refrigerant compressor to cycle off.



ENGINEERING YOUR SUCCESS.

## Technical Data

Dryer Models		Min Operating Pressure		Max Operating Pressure		Min Operating		Max Operating		Max Ambient		Electrical Supply	Electrical Supply (Optional)	Thread	Noise Level	Refrigerant Type
		psi g	bar g	psi g	bar g	°F	°C	°F	°C	°F	°C				dB(A)	
SPS 010 - 050	ISO 8573-1 Class 5	29	2	232	16	41	5	149	65	122	50	115V 1ph 60Hz	N/A	NPT	<75	R513A
SPS 075-175				203	14								230V 1Ph 60Hz			
SPS 200 - 250				230V 1ph 60Hz	N/A											

## Flow Rates

Model	Pipe Size	Inlet Flow Rate				kW
		cfm	m³/min	m³/hr	L/s	
SPS 010	1/2"	10	0.28	17.0	4.7	0.16
SPS 015	1/2"	15	0.42	25.5	7.1	0.17
SPS 025	1/2"	25	0.71	42.5	11.8	0.19
SPS 035	3/4"	35	0.99	59.5	16.5	0.18
SPS 050	3/4"	50	1.42	85.0	23.6	0.20
SPS 075	1"	75	2.12	127.4	35.4	0.36
SPS 0100	1"	100	2.83	169.9	47.2	0.37
SPS 0125	1"	125	3.54	212.4	59.0	0.38
SPS 0150	1 1/2"	150	4.25	254.9	70.8	0.56
SPS 0175	1 1/2"	175	4.96	297.3	82.6	0.69
SPS 0200	1 1/2"	200	5.66	339.8	94.4	0.90
SPS 0250	1 1/2"	250	7.08	424.8	118.0	0.91

Stated flows are for operation at the following climatic conditions: 100°F (38°C) Ambient Temperature, 100°F (38°C) Inlet Temperature and 100 psi g (7 bar g) Inlet Pressure.

For flows at other conditions, apply the correction factors shown below.

## Product Selection & Correction Factors

For correct operation, compressed air dryers must be sized using for the maximum inlet temperature, maximum ambient temperature, minimum inlet pressure and maximum flow rate of the installation. To select a dryer, first calculate the MDC (Minimum Drying Capacity) using the formula below then select a dryer from the flow rate table above with a flow rate equal to or above the MDC.

**Minimum Drying Capacity = System Flow x CFIT x CFAT x CFMIP**

### CFIT - Correction Factor Minimum Inlet Temperature

Minimum Inlet Temperature	°F	90	95	100	110	120	130	140	149
	°C	32	35	38	43	49	54	60	65
Correction Factor		0.74	0.82	1	1.33	1.76	2.38	2.60	2.67

### CFAT - Correction Factor Maximum Ambient Temperature

Maximum Ambient Temperature	°F	60	70	80	90	95	100	110	120	122
	°C	16	21	27	32	35	38	43	49	50
Correction Factor		0.93	0.93	0.93	0.93	0.96	1	1.08	1.16	1.18

### CFMIP - Correction Factor Minimum Inlet Pressure

Minimum Inlet Pressure	psi g	45	60	80	100	125	150	160	175	203	232
	bar g	3	4	5.5	7	8.5	10	11	12	14	16
Correction Factor		1.40	1.17	1.09	1	0.88	0.82	0.81	0.79	0.75	0.71

## Controller Functions

Dryer Model	Power On Indication	Visual Fault Indication	Compressed Air Temperature	EST - Energy Saving Technology	Dryer Service Indicator	Fault Relay: Power Loss	4-20mA for Dewpoint Retransmission
SPS 010 - 250	X	X	X		X	X	
SPS 075 - 250 w/ EST Option	X	X	X	X	X	X	X

## Recommended Filtration

Model	Pipe Size	Dryer Inlet	Dryer Outlet	Filtration Performance	General Purpose Pre-filter	High Efficiency After Filter
		General Purpose Pre Filter	High Efficiency After Filter			
SPS 010	½"	AOP010CNFI	AAP010CNFI	<b>Filtration Grade</b>	Grade AO	Grade AA
SPS 015	½"	AOP015CNFI	AAP015CNFI	<b>Filtration Type</b>	Coalescing	Coalescing
SPS 025	½"	AOP015CNFI	AAP015CNFI	<b>Particle Reduction (inc water &amp; oil aerosols)</b>	Down to 1 micron	Down to 0.01 micron
SPS 035	¾"	AOP020DNFI	AAP020DNFI	<b>Maximum Remaining Oil Aerosol Content at 70°F (21°C)</b>	≤0.5 mg/m³ (≤0.5 ppm(w))	≤0.01 mg/m³ (≤0.01 ppm(w))
SPS 050	¾"	AOP020DNFI	AAP020DNFI			
SPS 075	1"	AOP025ENFI	AAP025ENFI			
SPS 0100	1"	AOP025ENFI	AAP025ENFI			
SPS 0125	1"	AOP025ENFI	AAP025ENFI			
SPS 0150	1 ½"	AOP030GNFI	AAP030GNFI			
SPS 0175	1 ½"	AOP030GNFI	AAP030GNFI			
SPS 0200	1 ½"	AOP035GNFI	AAP035GNFI			
SPS 0250	1 ½"	AOP035GNFI	AAP035GNFI			

## Weights & Dimensions

Model	Pipe Size	Dimensions						Weight	
		Height (H)		Width (W)		Depth (D)		lbs	kg
		ins	mm	ins	mm	ins	mm		
SPS 010	½"	20.5	520	11.8	300	15.7	400	53	24
SPS 015	½"	20.5	520	11.8	300	15.7	400	53	24
SPS 025	½"	20.5	520	11.8	300	15.7	400	55	25
SPS 035	¾"	22.8	580	13.0	330	21.7	550	77	35
SPS 050	¾"	22.8	580	13.0	330	21.7	550	79	36
SPS 075	1"	25.6	650	15.7	400	24.8	630	101	46
SPS 0100	1"	25.6	650	15.7	400	24.8	630	101	46
SPS 0125	1"	25.6	650	15.7	400	24.8	630	104	47
SPS 0150	1 ½"	25.6	650	15.7	400	24.8	630	117	53
SPS 0175	1 ½"	25.6	650	15.7	400	24.8	630	121	55
SPS 0200	1 ½"	33.1	840	17.7	450	30.7	780	176	80
SPS 0250	1 ½"	33.1	840	17.7	450	30.7	780	176	80

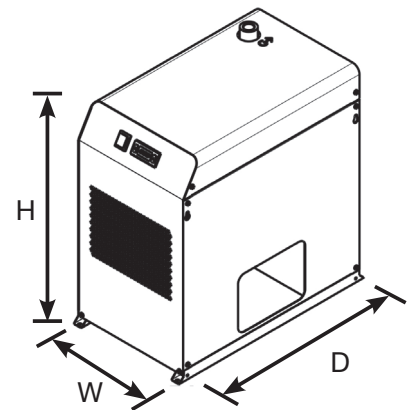

## Quality Assurance / IP Rating / Pressure Vessel Approvals

Development / Manufacture	ISO 9001 / ISO 14001
Ingress Protection Rating	IP22 Indoor Use Only
For use with compressed air only	

# Parker Filtration Group

**Aerospace Filtration Division**  
Greensboro, North Carolina  
336 668 4444

**Bioscience & Water Filtration Division**  
Bioscience Filtration  
Oxnard, California  
877 784 2234

Water Purification  
Carson, California  
310 608 5600

**Engine Mobile Aftermarket Division**  
Kearney, Nebraska  
308 234 1951

**Engine Mobile Original Equipment Division**  
Modesto, California  
209 521 7860

**HVAC Filtration Division**  
Jeffersonville, Indiana  
866 247 4827

**Hydraulic & Fuel Filtration Division**  
Metamora, Ohio  
419 644 4311

**Industrial Gas Filtration & Generation Division**  
Lancaster, NY  
800 343 4048

**Industrial Process Filtration Division**  
Mineral Wells, Texas  
940 325 2575

**Bioscience Engineering Filtration Division EMEA**  
Birtley, United Kingdom  
+44 (0) 191 410 5121

**Engine Mobile Filtration Division EMEA**  
Dewsbury, United Kingdom  
+44 (0) 1924 487 037

**Gas Separation & Filtration Division EMEA**  
Team Valley, United Kingdom  
+44 (0) 191 402 9000

**Gas Turbine Filtration Division**  
Alton, United Kingdom  
+44 (0) 1420 541188

**Hydraulic & Industrial Filtration Division EMEA**  
Arnhem, Netherlands  
+31 (0) 26 376 0376

**Australia Filtration Division**  
Castle Hill, Australia  
+61 2 9634 7777

**China Filtration Division**  
Shanghai, China  
+86 21 2067 2067

**India Filtration Division**  
Chennai, India  
+91 22 4391 0700

**Korea Filtration Division**  
Hwaseon City, Korea  
+82 31 359 0852

**Latin America Filtration Division**  
Sao Paulo, Brazil  
+55 12 4009 3500

