



MAKE POWER MOVES.



Portable Air Compressors
185 — 1600 cfm

DOOSAN[®]
Portable Power

Table of Contents

- About Us 1
- Powerful Solutions 2
- Small Air 3-6
 - P185
 - P185 Utility
 - XP185
 - C185
 - P250/HP210
- Medium Air 7-8
 - P425/HP375
 - HP450/VHP400
- Large Air 9-10
 - XP825/HP750
- Extra Large Air/
Low Pressure 11-12
 - HP915
 - HP1600
- Extra Large Air/
High Pressure 13-14
 - XHP750
 - XHP1170
- Drill Modules 15
- IQ System 16
- Specifications 17-20
- Doosan Portable Power
Full Line Overview 21-22



DOOSAN® Portable Power

About Us

Doosan Portable Power has more than 100 years of manufacturing expertise and application experience, with a focus on providing the highest quality machines with unrivaled customer service. Our market leading product line of portable air compressors, generators and light towers are proudly built in the USA. Doosan Portable Power is headquartered in Statesville, North Carolina, and was established in 2007 when Doosan Infracore purchased Ingersoll-Rand's Utility Equipment division.

Today, Doosan Portable Power is a subsidiary of Doosan Bobcat Inc. Doosan Bobcat is an industry leader in the engineering, manufacturing and marketing of construction equipment, and also represents the Bobcat brand. Doosan Bobcat is committed to delivering innovative products and services that provide quality and value.





Powerful Solutions

At Doosan Portable Power, we do more than provide superior products. We deliver powerful solutions to move your business forward. Robust compressors that perform on the most demanding job sites. Generators and light towers that are reliable and efficient. Factor in our industry-leading service and support, and it's quite clear that partnering with us is a smart return on your investment.

Dependability

Our equipment is built to last with corrosion-resistant galvanized steel enclosures and a durable, baked-on powder coat finish. Extensive testing at our Statesville, North Carolina facility includes a test track, tilt table, and cold chamber to ensure our machines will perform in the harshest conditions and applications.

Doosan is fully committed to delivering quality machines that maximize uptime and minimize downtime to give you peace of mind.

“The quality is a 10. The durability is a 10.”

-Jack Anderson, Papé Material Handling

Performance

Doosan Portable Power gives you the power you need in the most efficient manner. We provide leading fuel economy and performance while ensuring compliance with the latest emissions standards.

Doosan also offers unmatched versatility to support almost every job or application. With user friendly controls and diagnostics, anyone can operate our equipment with minimal instruction.

“Doosan has always performed well for us.”

-Mark Grimes, Industrial Marine

Serviceability

Doosan has an extensive and knowledgeable dealer network. Our dealer-partners have a deep understanding of your business and can provide the solutions you demand.

All of our products are engineered and designed with an emphasis on accessibility to make sure routine maintenance is quick and easy to perform without having to take the machine apart.

“Parts and service are always there when we need it.”

- Mike Venuti, Meruelo Group



MORE STORAGE

The industry's largest full-length toolbox provides over 8,700 cubic inches of convenient tool and accessory storage.

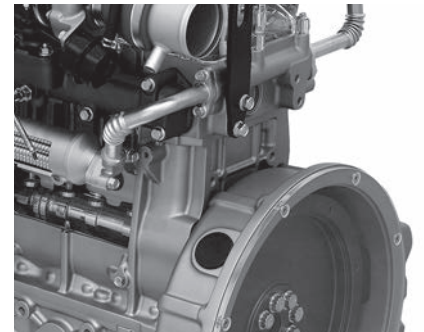

DOC ONLY

The high performance Doosan D24 engine features a diesel oxidation catalyst (DOC) aftertreatment system, which is virtually maintenance-free.

P185

Full specifications on page 18



FREE AIR DELIVERY | PRESSURE

185 cfm (5.2 m³/min) | 100 psig (6.9 bar)

With the most available options in the industry, the P185 can be customized to meet any job site need. This durable workhorse is powered by a Doosan D24 engine with a diesel oxidation catalyst (DOC) after-treatment system which is virtually maintenance-free.

The high-performance Doosan engine provides the P185 with reliable power, over 10 hours of run-time, and improved cold-starting capability. Its spin-on oil separation system offers the easiest and quickest maintenance in the industry. The P185 also boasts the industry's largest and deepest full-length toolbox, providing you with over 8,700 cubic inches of storage.

P185 Utility

Full specifications on page 18



FREE AIR DELIVERY | PRESSURE

185 cfm (5.2 m³/min) | 100 psig (7.0 bar)

The P185 utility compressor sets the standard for a skid-mounted, space-saving solution. Designed for above-deck installation and packaged with assorted options, the P185 utility blends performance and serviceability with curbside, digital controls and gauges. This quick-view, eye-level access improves safety and convenience.

An efficient, high performance Doosan D24 engine delivers 49 HP, and a runtime of 10 hrs. The engine's limiting air temperature (LAT) of 130° helps maximize uptime in hot conditions.

XP185

Full specifications on page 18



FREE AIR DELIVERY | PRESSURE

185 cfm (5.2 m³/min) | 125 psig (8.6 bar)

Doosan strives to provide its customers with products that maximize their productivity while also providing versatility on the job site.

The XP185 is just that, a compressor that provides 185cfm @125psi while simultaneously giving you the ability to provide power to what you need. Equipped with a 4kW onboard generator you can rest assured that the XP185 is up for whatever task the job site throws at it.

MAKE POWER MOVES.

DoosanPowerMoves.com

800.633.5206





SERVICEABILITY

Easy lift canopy provides ample room to work when performing routine maintenance.



EASE OF MAINTENANCE

Doosan's patented spin-on oil separation system allows for an industry leading replacement time of under 2-minutes

C185

Full specifications on page 18



FREE AIR DELIVERY | PRESSURE

185 cfm (5.2 m³/min) | 100 psig (6.9 bar)

For reliable power in a cost-efficient machine, turn to the C185. Packed with quality, performance, and serviceability for a wide variety of applications, the C185 delivers unmatched value in small package for effortless towing and maneuverability.

Inside, a simple spin-on separator element expedites service and maintenance, while the cool-box airflow design directs heat away from the unit to prolong life and minimize dust recirculation. Outside, the C185's polymer canopy combines strength with easy-access to routine service items. Its ample toolbox conveniently stores tools and accessories.

P250 / HP210

Full specifications on page 19



FREE AIR DELIVERY | PRESSURE

250 cfm (7.0 m³/min) / 210 cfm (5.9 m³/min)
100 psig (6.9 bar) / 150 psig (10.3 bar)

With dual-pressure and flow ratings, the indispensable P250/HP210 serves as two compressors in one. Able to increase productivity for a wide variety of jobs, including general construction, abrasive blasting and pipeline pressure testing, the unit is also ideal for powering hand-held pneumatic tools.

A robust frame, drawbar and independent suspension assures stability on and off the road. Its spin-on oil separation system offers the easiest and quickest maintenance in the industry. In addition, LED backlit gauges and durable engine start/push controls promote long-term, user-friendly operation.

MAKE POWER MOVES.

DoosanPowerMoves.com

800.633.5206



P425
HP375

DOOSAN

DOOSAN

P425/HP375

Full specifications on page 19



FREE AIR DELIVERY | PRESSURE

425 cfm (12 m³/min) / 375 cfm (10.6 m³/min)
100 psig (7 bar) / 150 psig (10.3 bar)



FUEL SAVINGS

An electronically controlled engine-driven cooling fan with a hydraulic clutch improves fuel efficiency and reduces noise.

HP450/VHP400

Full specifications on page 19



FREE AIR DELIVERY | PRESSURE

450 cfm (12.7 m³/min) / 400 cfm (11.3 m³/min)
150 psig (10.3 bar) / 200 psig (13.8 bar)



PRODUCTIVITY

The Doosan designed and manufactured DSN275 airend is efficient and delivers the high-volume cfm output to power applications like sand blasting.

Powered by a reliable Cummins 4.5L engine, the P425 and HP450 pair performance with productivity. A corrosion-resilient galvanized steel enclosure, A-frame drawbar, and heavy-duty axles promote durability, as a thermostatic cooling fan reduces noise and cuts fuel costs by an average 10% (in cold weather conditions).

With dual pressure and flow options, each compact unit easily switches from low- to high-pressure, meeting the needs of a wide range of applications. A five-gallon diesel exhaust fluid tank, small footprint and state-of-the-art control panel ease user operation, and Doosan's highly efficient airend demands less horsepower for high-volume cfm output.

MAKE POWER MOVES.

DoosanPowerMoves.com
800.633.5206



RBI4072

DOOSAN

**XP825
HP750**

4500 LBS

GALV ANNEALED STEEL
PER SAE J413

XP825/HP750

Full specifications on page 19



FREE AIR DELIVERY | PRESSURE

825 cfm (23.4 m³/min) / 750 cfm (21.2 m³/min)
125 psig (8.6 bar) / 150 psig (10.3 bar)

Intuitive machine diagnostics, low cost of ownership and job flexibility define the XP825/HP750. Backed by a Cummins engine, corrosion-resilient steel enclosure, and robust drawbar and axles, this durable model lets operators change from low- to high-pressure at the touch of a button.

As a thermostatic, clutch-driven cooling fan minimizes noise and fuel costs, a 100-gallon fuel tank delivers nine hours of runtime. Doosan's high-efficiency airend offers high-volume cfm output with less horsepower. And a diesel oxidation catalyst with selective catalytic reduction virtually eliminates emissions maintenance with no regeneration cycles.



AT-A-GLANCE

The redesigned control panel on the XP825/HP750 provides improved operator interface and easy-to-understand diagnostics.

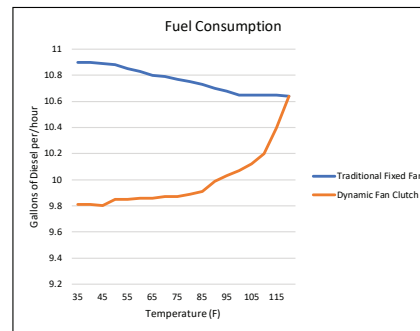

FUEL EFFICIENCY

The dynamic fan clutch provides over 12% fuel savings in cold environments.



EASY ACCESS

Airend consumables, fuel filters and dipstick are all centrally located for quick and easy maintenance.

**MAKE
POWER
MOVES.**

DoosanPowerMoves.com
800.633.5206



DOOSAN

488187

ATS EQUIPMENT

IQ SYSTEM

DoosanPortablePower.com

DOOSAN

HP1600

IQ SYSTEM

HP915

Full specifications on page 20



Built to excel in rugged conditions, the HP915 offers unparalleled serviceability for maximum uptime. Operation is equally easy with centralized fluid drain locations and a detailed control panel with more preloaded resources than any other model.

Compact yet powerful, the unit offers over 9 hours of reliable runtime and Doosan's patented IQ System for instrument-quality air and zero discharge condensate removal.

FREE AIR DELIVERY | PRESSURE

915 cfm (25.9 m³/min) | 150 psig (10.3 bar)



INSTRUMENT QUALITY AIR

We offer clean air systems — compressors, aftercoolers and water separation — that enable you to precisely meet ISO standards for your industry.

HP1600

Full specifications on page 20



Designed for long-term use and maximum productivity, the HP1600 packs advanced power and features in a modest footprint. Equipped with a tier 4 final compliant Cummins QSX15 engine, the HP1600 balances 580 horsepower at 1,800 rpm with quiet operation.

An environmentally friendly containment basin offers 110% fluid containment, and Doosan's coolbox design prolongs system life and eliminates lengthy cool-downs. An enhanced ViewPort control panel, easy access to manuals, full-color back-lit LED displays, and industry-leading service intervals streamline machine operation.

FREE AIR DELIVERY | PRESSURE

1600 cfm (45.3 m³/min) | 150 psig (10.3 bar)

**MAKE
POWER
MOVES.**

DoosanPowerMoves.com
800.633.5206



DOOSAN

XHP1170

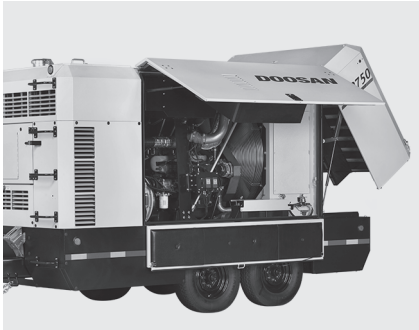

EASE OF MAINTENANCE

The enclosure design of the XHP750 provides industry-leading accessibility for ease of service and maintenance.

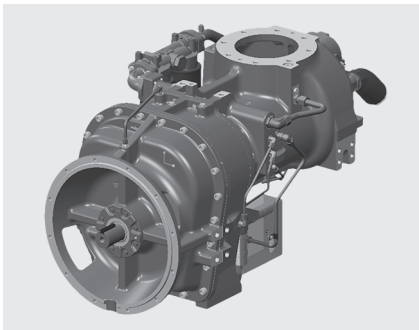

DURABILITY

The XHP750 and XHP1170 models are equipped with a Doosan HR350 airend that requires less horsepower to deliver a high volume cfm output.

XHP750

Full specifications on page 20



FREE AIR DELIVERY | PRESSURE

750 cfm (21.2 m³/min)
140 – 365 psig (9.7 – 24.1bar)

The XHP750 provides high pressure air in the smallest package in the industry. Exterior design includes gull-wing doors, drop-down tailgate, and a cooler access hatch to provide the industry's best servicing capability.

Intuitive joystick control, instant access to 15 operational parameters, a built-in machine maintenance schedule, and handy spare parts and manual information simplify operation further.

XHP1170

Full specifications on page 20



FREE AIR DELIVERY | PRESSURE

1170 cfm (33.1 m³/min)
365 psig (25.1 bar)

The industry's first Tier4 Final-compliant high-pressure air compressor with dual pressure of 250 or 365 psi, the XHP1170 houses premium features without the added cost. Fitted with a Doosan-manufactured HR350 airend, the unit delivers a high volume of air with less horsepower for 5% greater fuel economy.

A powerful Cummins QSX15 engine includes a selective catalytic reduction (SCR) and diesel particulate filter (DPF) after-treatment system. Twin, over 100 gallon fuel tanks combine for eight hours of runtime at 100% load.

MAKE POWER MOVES.

DoosanPowerMoves.com
800.633.5206



Drill Modules

Doosan Portable Power offers a full line of drill modules from low pressure to high pressure to meet all your requirements for drilling. These reliable and robust modules are built to perform and deliver a solid return on your investment.

- Heavy-duty, single and two-stage rotary screw compressors are designed for mobile applications.
- Single-stage rotary screw compressor modules feature a hydraulically driven fan for oil cooling.
- Two-stage, high-pressure modules offer choice of shaft drive (CM or CMH) or direct engine coupling (CMH only).
- All packages are built with a heavy-gauge sheet metal housing for durability, and external airend lines are made of steel tubing to ensure a long life.
- User-friendly instrumentation includes analog gauges for separator discharge pressure and airend discharge temperature.
- Shutdown switches have been installed for airend and separator discharge temperature (normally closed at 248°F).
- Modules are designed to provide easy access for maintenance and serviceability.

TWO-STAGE HIGH PRESSURE MODULES

RATED CAPACITY – cfm (m³/min)
750 (21.2) to 1250 (35.4)

PRESSURE – psi (bar)
350 (24.1)



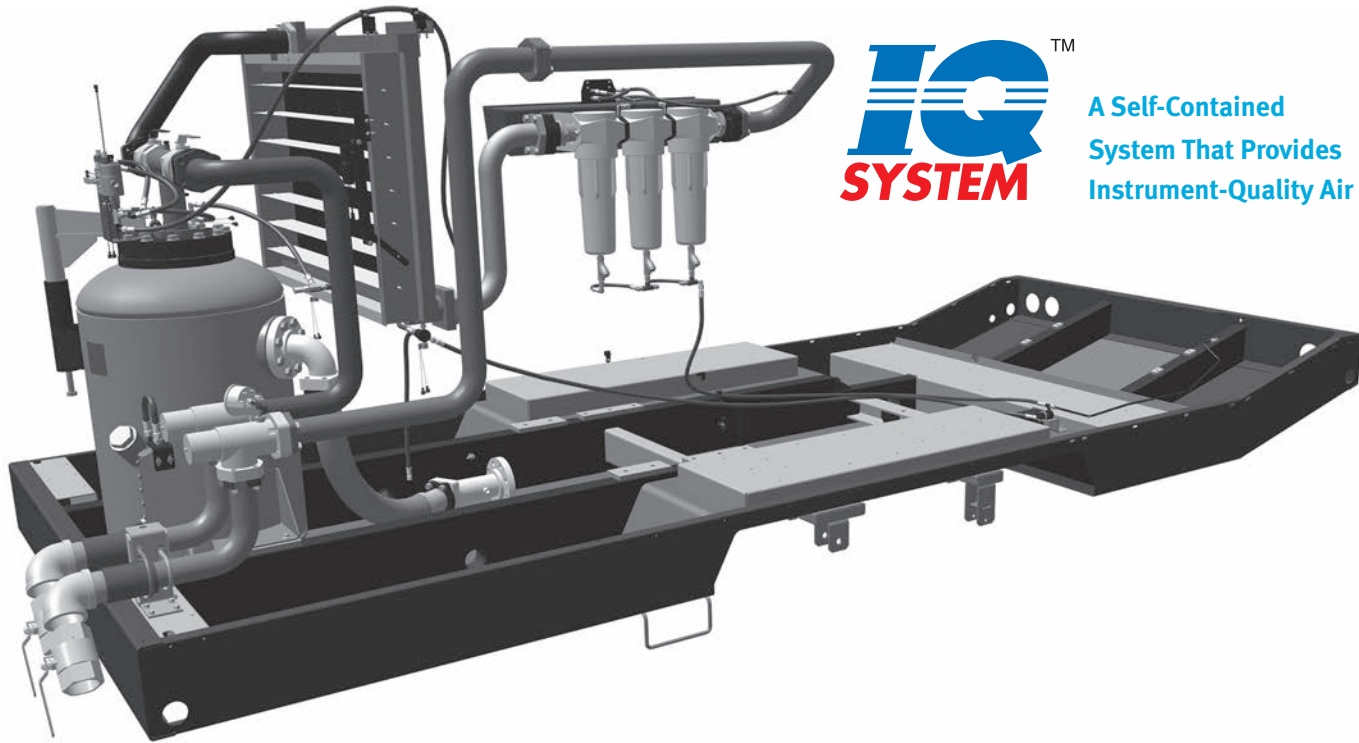

Water Separator and IQ Filters

IQ System

Clean air is essential to the safety and efficiency of compressed air applications. From highly regulated jobsites to finished products such as steel structure painting, the need for clean, dry air continues to grow.

Doosan Portable Power IQ System air compressors provide instrument-quality air that is 99.99 percent free of contaminants — removing harmful dust, dirt, moisture and oil that are present in untreated air. The IQ system is equipped with a patented condensate removal process that vaporizes any moisture present

in ambient air to provide zero discharge and an internal aftercooler ensures compressed air is 20 degrees F above ambient air temperature.

A dual-filter system includes early warning indicators when filters require maintenance, while a pressure differential feature senses buildup in the filters and will safely shutdown the unit to ensure a consistent, reliable source of high-quality air. The result is clean, dry, cool, portable, compressed air.

The unique, onboard IQ system is fully-enclosed within the Doosan air compressor design. The all-in-one package provides the same portability customers expect from Doosan Portable Power equipment. The IQ system also delivers on versatility with the ability to select instrument-quality air or standard compressed air for applications that don't require pure, dry air. A lockable valve system makes it easy to instantly switch between the two options to tackle a variety of applications all in one day, saving time and money.



Specifications

DOOSAN

Model	P185WDO-T4F	P185WDOU-T4F	XP185WDO-T4F	C185WDO-T4F
COMPRESSOR ROTARY SCREW/SINGLE-STAGE				
Free-Air Delivery – cfm (m3/min)	185 (5.2)	185 (5.2)	185 (5.2)	185 (5.2)
Rated Operating Pressure – psig (bar)	100 (6.9)	100 (6.9)	125 (8.6)	100 (6.9)
Pressure Range – psig (bar)	80 – 125 (5.5 – 8.6)	80 – 125 (5.5 – 8.6)	80 – 125 (5.5 – 8.6)	80 – 125 (5.5 – 8.6)
Air Discharge Outlet NPT Size – in (mm)	0.75 (19)	0.75 (19)	0.75 (19)	0.75 (19)
Air Discharge Outlet Quantity	2	2	2	2
Fuel Tank Capacity – gal (L)	34.5 (130.6)	27 (102)	34.5 (130.6)	34.5 (130.6)
ENGINE				
Make/Model	Doosan D24	Doosan D24	Doosan D24	Doosan D18
Emissions Tier Level	Tier 4 Final (T4F)	Tier 4 Final (T4F)	Tier 4 Final (T4F)	Tier 4 Final (T4F)
Number of Cylinders	4	4	4	3
Displacement – cu in (L)	147 (2.4)	147 (2.4)	147 (2.4)	110 (1.8)
Rated Speed – rpm	2600	2600	2600	2600
Idle Speed – rpm	1700	1700	1700	1700
Bhp @ Rated Speed (kW)	49 (36.6)	49 (36.4)	74 (55)	49 (36.6)
Electrical – volts	12	12	12	12
Hours of Operation @ Full Load	12.2	12.2	11	12.6
DIMENSIONS WITH RUNNING GEAR				
Length – in (mm)	136.7 (3473)	N/A	136.7 (3473)	137.4 (3490)
Width – in (mm)	68.8 (1746)	N/A	68.8 (1746)	68.5 (1740)
Height – in (mm)	67.3 (1710)	N/A	67.3 (1710)	67.5 (1715)
Track Width – in (mm)	60.3 (1530)	N/A	60.3 (1530)	60 (1524)
Tire Size – in	15	N/A	15	13
Shipping Weight – w/o fuel – lb (kg)	2305 (1046)	N/A	2305 (1046)	2209 (1002)
Working Weight – w fuel – lb (kg)	2551 (1157)	N/A	2551 (1157)	2455 (1113)
DIMENSIONS WITHOUT RUNNING GEAR				
Length – in (mm)	88.5 (2248)	84 (2133)	88.5 (2248)	88.8 (2256)
Width – in (mm)	49.3 (1252)	33.3 (846)	49.3 (1252)	49.2 (1250)
Height – in (mm)	56.3 (1431)	52.5 (1334.59)	56.3 (1431)	64.4 (1636)
Shipping Weight – w/o fuel – lb (kg)	2095 (950)	2034 (922)	2095 (950)	1994 (904)
Working Weight – w fuel – lb (kg)	2341 (1062)	2300 (1043.3)	2341 (1062)	2240 (1016)

Specifications

Model	P250/HP210WDO-T4F		P425/HP375WCU-T4F		HP450/VHP400WCU-T4F		XP825/HP750WCU-T4F	
COMPRESSOR ROTARY SCREW/SINGLE-STAGE	LOW PRESSURE	HIGH PRESSURE	LOW PRESSURE	HIGH PRESSURE	LOW PRESSURE	HIGH PRESSURE	LOW PRESSURE	HIGH PRESSURE
Free-Air Delivery – cfm (m3/min)	250 (7.0)	210 (5.9)	425 (12.0)	375 (10.6)	450 (12.7)	400 (11.3)	825 (23.4)	750 (21.2)
Rated Operating Pressure – psig (bar)	100 (7.0)	150 (10.3)	100 (6.9)	150 (10.3)	150 (10.3)	200 (13.8)	125 (8.6)	150 (10.3)
Pressure Range – psig (bar)	80 – 175 (5.5 – 12.1)		80 - 175 (5.5 - 12.1)		80 - 225 (5.5 - 15.5)		80-175 (5.5-12.1)	
Air Discharge Outlet NPT Size – in (mm)	0.75 (19)		1.25 (31.8)		1.25 (31.8)		2-inch NPT (50.8)	
Air Discharge Outlet Quantity	2		1		1		1	
Fuel Tank Capacity – gal (L)	34.5 (130.6)		60 (227)		60 (227)		100 (379)	
ENGINE								
Make/Model	Doosan D24		Cummins/F3.8L		Cummins/F3.8L		Cummins/QSB6.7	
Emissions Tier Level	Tier 4 Final (T4F)		Tier 4 Final (T4F)		Tier 4 Final (T4F)		Tier 4 Final (T4F)	
Number of Cylinders	4		4		4		6	
Displacement – cu in (L)	147 (2.4)		231 (3.8)		231 (3.8)		408 (6.7)	
Rated Speed – rpm	2550	2200	2300	2075	2500	2250	2100	1935
Idle Speed – rpm	1700		1500		1500		1300	
Bhp @ Rated Speed (kW)	74 (55.2)	72.6 (54.1)	135 (100.6)	134 (99)	173 (129)	172 (128)	266 (198)	262 (195)
Electrical - volts	12		24		24		24	
Hours of Operation @ Full Load	8.7	9.1	10	9	8	8	9.1	9.3
DIMENSIONS WITH RUNNING GEAR								
Length – in (mm)	142.7 (3625)		152.5 (3874)		152.5 (3874)		203 (5164)	
Width – in (mm)	68.8 (1746)		78.2 (1986)		78.2 (1986)		90.2 (2291)	
Height – in (mm)	67.3 (1710)		69.9 (1775)		69.9 (1775)		88.5 (2248)	
Track Width – in (mm)	60.3 (1530)		66.6 (1692)		66.6 (1692)		80.3 (2040)	
Tire Size – in	15		15		15		15	
Shipping Weight – w/o fuel – lb (kg)	2375 (1069)		4334 (1966)		4334 (1966)		8620 (3910)	
Working Weight – w fuel – lb (kg)	2595 (1177)		4776 (2166)		4776 (2166)		9330 (4230)	
DIMENSIONS WITHOUT RUNNING GEAR								
Length – in (mm)	94.6 (2403)		104.2 (2647)		104.2 (2647)		152.4 (3871)	
Width – in (mm)	49.3 (1252)		60.7 (1542)		60.7 (1542)		80.6 (2047)	
Height – in (mm)	56.3 (1431)		61 (1549)		61 (1549)		79 (2007)	
Shipping Weight – w/o fuel – lb (kg)	2147 (974)		4071 (1846)		4071 (1846)		7840 (3560)	
Working Weight – w fuel – lb (kg)	2385 (1082)		4513 (2047)		4513 (2047)		8550 (3880)	

Model	HP915WCU-T4F	HP1600WCU-T4F
COMPRESSOR ROTARY SCREW/SINGLE-STAGE		
Free-Air Delivery – cfm (m ³ /min)	915 (25.9)	1600 (45.3)
Rated Operating Pressure – psig (bar)	150 (10.3)	150 (10.3)
Pressure Range – psig (bar)	80 - 175 (5.5 - 12.1)	80 - 175 (5.5 - 12.1)
Air Discharge Outlet NPT Size – in (mm)	2 (50.8)	3 (76.2)
Air Discharge Outlet Quantity	1	1 (2 with IQ)
Fuel Tank Capacity – gal (L)	128 (485)	231 (876)
ENGINE		
Make/Model	Cummins/QSL9	Cummins/QSX15
Emissions Tier Level	Tier 4 Final (T4F)	Tier 4 Final (T4F)
Number of Cylinders	6	6
Displacement – cu in (L)	543 (8.9)	912 (14.9)
Rated Speed – rpm	1800	1800
Idle Speed – rpm	1200	1200
Bhp @ Rated Speed (kW)	303 (226)	580 (433)
Electrical - volts	24	24
Hours of Operation @ Full Load	8.7	8.13
DIMENSIONS WITH RUNNING GEAR		
Length – in (mm)	226.6 (5748)	292.4 (7427)
Width – in (mm)	82.6 (2098)	90.1 (2289)
Height – in (mm)	101.3 (2573)	99.5 (2527)
Track Width – in (mm)	69.3 (1760)	71 (1803)
Tire Size – in	16	17.5
Shipping Weight – w/o fuel – lb (kg)	10461 (4745)	17874 (8108)
Working Weight – w fuel – lb (kg)	11309 (5130)	19565 (8875)
DIMENSIONS WITHOUT RUNNING GEAR		
Length – in (mm)	171 (4343)	228.2 (5796)
Width – in (mm)	83 (2108)	90.1 (2289)
Height – in (mm)	95 (2413)	98.2 (2494)
Shipping Weight – w/o fuel – lb (kg)	9740 (4418)	16899 (7665)
Working Weight – w fuel – lb (kg)	10765 (4883)	18590 (8432)

Model	XHP750WCU-T4F	XHP1170WCU-T4F
COMPRESSOR		
Free-Air Delivery – cfm (m ³ /min)	750 (21.2)	1170 (33.1)
Rated Operating Pressure – psi (bar)	350 (24.1)	365 (25.1)
Pressure Range – psig (bar)	140-365 (9.7-24.1)	140-365 (9.7-25.2)
Air Discharge Outlet NPT Size – in (mm)	2 (50.8)	3 (76.2)
Air Discharge Outlet Quantity	1	1 (2 with IQ)
Compressor Oil Capacity – gal (L)	26.7 (101)	55 (208)
ENGINE		
Engine Make/Model	Cummins/QSL9	Cummins/QSX15
Emissions Tier Level	Tier 4 Final (T4F)	Tier 4 Final (T4F)
# of Cylinders	6	6
Displacement – cu in (L)	543 (8.9)	912 (14.9)
Rated Speed – rpm	1800	1800
Idle Speed – rpm	1350	1200
Bhp @ Rated Speed (kW)	340 (254)	580 (433)
Electrical – volts	24	24
Engine Oil Capacity – qt (L)	23.2 (22)	48 (45)
Radiator Coolant Capacity – gal (L)	15.3 (58)	26 (98)
Altitude Capability – ft (m)	9000 (2743)	9800 (2987)
Fuel Consumption @ 100% load – gph (L/h)	15.9 (60.2)	23.5 (89)
Fuel Tank Capacity – gal (L)	128.1 (485)	222.4 (841.9)
DEF Tank Capacity - gal (L)	10 (38)	15.6 (59)
DIMENSIONS WITH RUNNING GEAR		
Overall Length – in (mm)	226.3 (5748)	292.4 (7427)
Overall Width – in (mm)	82.6 (2099)	90.1 (2289)
Overall Height – in (mm) excluding exh pipe	101.3 (2573)	99.5 (2527)
Track Width – in (mm)	69.3 (1760)	71 (1803)
Tire Size – in	16	17.5
Shipping Weight w/o fuel – lb (kg)	11067 (5020)	17355 (7871)
Working Weight w/ fuel – lb (kg)	12213 (5540)	18835 (8542)
DIMENSIONS WITHOUT RUNNING GEAR		
Overall Length – in (mm)	171 (4343)	228.2 (5796)
Overall Width – in (mm)	83 (2109)	90.1 (2289)
Overall Height – in (mm) w/ shockmounts	95 (2413)	98.2 (2494)
Shipping Weight w/o fuel – lb (kg)	10346 (4693)	16169 (7333)
Working Weight w/ fuel – lb (kg)	11669 (5293)	17860 (8100)

Lighting Systems



LCV & BALLOON LIGHT

For reliable illumination of special events, road and bridge construction, emergency and disaster relief, and general construction sites, choose a Doosan Portable Power lighting system. Our LCV light tower has a compact footprint and an industry leading runtime of 105 hours on a single fill. The BL2000 balloon light provides 2,000 watts of light and is the optimal choice for applications where glare-free light is required.

Light Compaction

Upright Rammers



RX-264H | RX-304H | RX-344H

Charged with industry-leading impact forces

Reversible Vibratory Plate Compactors



BXR-60H | BXR-100H | BXR-200H | BXR-300H

Built to perform, built to last

Forward Vibratory Plate Compactors



BX-60WH | BX-80WH | BX-120WH

Versatility & reliability

Walk-Behind Vibratory Rollers



**SX-170H | DX-500E | DX-600H | DX-600E
DX-700H | DX-700E**

Smooth, efficient compaction in complex applications

Generators

Small



G25 | G40 | G50

Doosan Portable Power features a comprehensive mobile generator line up, ready to supply the power you need at the touch of a button. With customer friendly control panels, no generator has ever been easier to use.

Medium



G70 | G125 | G150

Challenging applications demand powerful alternators. Doosan specifies high-output, separately excited alternators that ensure unmatched motor starting capability and precision voltage control.

Large



G190 | G240 | G325 | G400

Doosan mobile generators have been designed with the service technician in mind. With 500 hour intervals between fluid and filter exchanges, you can be sure that downtime for maintenance is minimized. All maintenance points are easily accessible and designed for fast and easy service.



OIL, FILTERS & LUBRICANTS

Protect your investment in quality equipment with genuine OEM parts. Doosan Portable Power is your source for the highest-quality parts, filters and lubricants for your Doosan Portable Power products.

For information, please contact:
800-633-5206
portablepowersales@doosan.com

Or visit the Doosan Portable Parts Store:
www.doosanportableparts.com

AVOID WET STACKING



AUTONOMOUS OPERATION



COLD TEMP



INCREASED UPTIME



ILMS - INTELLIGENT LOAD MANAGEMENT SYSTEM

Light loads and extreme cold can wreak havoc on your diesel generator. The Doosan Portable Power optional Intelligent Load Management System (ILMS) solves the wet stacking problem and keeps your generator operating longer and stronger - reducing costly repairs and downtime.

ILMS automatically raises the engine and exhaust temperature with supplemental heat, achieving the optimal operating temperature to prevent diesel generator wet stacking and ensure generator performance in light load and fluctuating conditions. Engine manufacturers require a minimum of 30% load on the engine for optimum performance. If you have a small load at your jobsite, the ILMS option will allow you to meet that requirement, resulting in increased performance and reliability without sacrificing capacity or fuel economy.

DOOSAN[®]

Portable Power

Experience Doosan Portable Power and our industry-leading support and service. Whatever the job, we have the solution. From our comprehensive range of reliable air compressors, to lighting systems and generators, we have a solution to fit your needs. Running a successful business takes more than powerful equipment. That's why Doosan Portable Power partners with an experienced dealer network to stand beside you every step of the way. Doosan Portable Power — more than 100 years of providing excellence.



Doosan Portable Power
1293 Glenway Drive
Statesville, NC 28625
DoosanPowerMoves.com

©2020 Doosan Infracore Portable Power
Rev 1

Product improvement is a continuous goal at Doosan Infracore Portable Power. Specifications and design are subject to change without notice or obligation. Warranty terms and conditions on new product sales are subject to change. All products are subject to the terms of the applicable warranty in effect on the date of purchase; contact your local Doosan dealer for the current applicable warranty. DOOSAN and the Doosan logo are trademarks of Doosan Corporation.