

CDAS – Clean Dry Air System

CDAS HL 050 - CDAS HL 085



Adsorption Dryers

Whether a compressed air user wants to control the growth of micro-organisms (essential for direct and in-direct contact applications in the food, beverage & pharmaceutical industries), ensure air used for critical applications / instrumentation is free from water contamination or has external piping where low ambient temperature can cause condensation, adsorption dryers are the go to dryer technology.

There are many different adsorption dryer technologies available and whilst they all reduce water from the compressed air in the same way, they differ in the way they regenerate the desiccant material.

Heatless Adsorption Dryers

The simplest and most common method used to regenerate the adsorbent desiccant material is the 'heatless' method (so called as it does not use heat for desiccant regeneration).

Using a proportion of the clean, dry process air for regeneration, heatless dryers typically have the lowest capital costs of all adsorption dryer types (due to the simplicity of the heatless design).

Being very robust and having fewer components, they typically have the lowest maintenance cost of all the adsorption technologies.

Heatless dryers are available to suit all compressed air flow rates from small to large, whereas the more complicated regeneration methods are often only available for higher flow rates due to cost and complexity of the designs.



Advantages

- Parker CDAS dryers provide a constant outlet dewpoint in accordance with ISO8573-1 classes 1, 2 or 3 for water vapour
- Parker CDAS dryers provide an outlet dewpoint which inhibits the growth of micro-organisms (allowing their efficient reduction using filtration)
- Parker CDAS dryers use clean, dry purge air for regeneration, eliminating any risk of damage to the adsorption bed or re-contamination of the downstream compressed air
- Parker CDAS dryer performance has been tested in accordance with ISO7183, the international standard for compressed air dryer testing
- The dewpoint performance of Parker CDAS dryers has been 3rd party validated by Lloyds Register to ISO8573-1 air purity classifications
- No heat is used for regeneration; therefore, no insulation is required and loss of dewpoint on column changeover due to inefficient cool down is eliminated
- Parker CDAS dryers include Parker OIL-X General Purpose & High Efficiency Coalescing pre-filtration and General Purpose Dry Particulate post filtration as standard
- Full feature electronic control with dewpoint display and Energy Saving Technology fitted as standard



Dryer Performance

Dryer Models	Dewpoint (Standard)		ISO8573-1:2010 Classification (Standard)	Dewpoint (Option 1)		ISO8573-1:2010 Classification (Option 1)	Dewpoint (Option 2)		ISO8573-1:2010 Classification (Option 2)
	°C	°F		°C	°F		°C	°F	
CDAS HL	-40	-40	Class 2.2.2	-70	-100	Class 2.1.2	-20	-4	Class 2.3.2

ISO8573-1 Classifications when used with Parker OIL-X pre / post filtration

Technical Data

Dryer Models	Minimum Operating Pressure		Maximum Operating Pressure		Minimum Operating Temperature		Maximum Operating Temperature		Maximum Ambient Temperature		Electrical Supply (Standard)	Electrical Supply (Optional)	Thread Type	Noise Level dB(A)
	bar g	psi g	bar g	psi g	°C	°F	°C	°F	°C	°F				
CDAS HL 050 - 085	4	58	16	232	5	41	50	122	55	131	100-240V (+/-10%) 1ph 50/60Hz	24V DC	BSPP or NPT	<75

Flow Rates

Model	Pipe Size BSPP or NPT	Inlet Flow Rate			
		L/s	m³/min	m³/hr	cfm
CDAS HL 050	½"	15	0.92	55	32
CDAS HL 055	½"	19	1.17	70	41
CDAS HL 060	½"	25	1.50	90	53
CDAS HL 065	½"	31	1.84	110	65
CDAS HL 070	¾"	42	2.51	150	88
CDAS HL 075	1"	51	3.09	185	109
CDAS HL 080	1"	61	3.67	220	129
CDAS HL 085	1½"	83	5.01	300	177

Stated flows are for operation at 7 bar (g) (102 psi g) with reference to 20°C, 1 bar (a), 0% relative water vapour pressure. For flows at other pressures, apply the correction factors shown below.

Product Selection & Correction Factors

For correct operation, compressed air dryers must be sized using for the maximum (summer) inlet temperature, maximum (summer) ambient temperature, minimum inlet pressure, required outlet dewpoint and maximum flow rate of the installation.

To select a dryer, first calculate the MDC (Minimum Drying Capacity) using the formula below then select a dryer from the flow rate table above with a flow rate equal to or above the MDC.

Minimum Drying Capacity = System Flow x CFIT x CFAT x CFMIP x CFOD

CFIT - Correction Factor Maximum Inlet Temperature

Maximum Inlet Temperature	°C	25	30	35	40	45	50
	°F	77	86	95	104	113	122
Correction Factor		1.00	1.00	1.00	1.04	1.14	1.37

CFAT - Correction Factor Maximum Ambient Temperature

Maximum Ambient Temperature	°C	25	30	35	40	45	50
	°F	77	86	95	104	113	122
Correction Factor		1.00	1.00	1.00	1.00	1.00	1.00

CFMIP - Correction Factor Minimum Inlet Pressure

Minimum Inlet Pressure	bar g	4	5	6	7	8	9	10	11	12	13	14	15	16
	psi g	58	73	87	100	116	131	145	160	174	189	203	218	232
Correction Factor		1.60	1.33	1.14	1.00	0.89	0.80	0.73	0.67	0.62	0.57	0.53	0.50	0.47

CFOD - Correction Factor Outlet Dewpoint

Outlet Dewpoint	°C	-20	-40	-70
	°F	-4	-40	-100
Correction Factor		0.91	1.00	2.00

Controller Functions

Dryer Models	Controller Function							
	Power On Indication	Visual Fault Indication	Dewpoint Display	EST - Energy Saving Technology	Filter Service Indicator	Dryer Service Indicator	Fault Relay: Power Loss Dewpoint Alarm Sensor Failure	4-20mA Dewpoint Re-transmission
CDAS HL	•	•	•	•	•	•	•	•

Included Filtration

Model	Pipe Size BSPP or NPT	Dryer Inlet		Dryer Outlet		
		General Purpose Pre-filter	High Efficiency Filter	Oil Vapour Reduction Filter	General Purpose Dry Particulate Filter	High Efficiency Dry Particulate Filter
CDAS HL 050	½"	AOPX015C	AAPX015C	-	AOPX015C	-
CDAS HL 055	½"	AOPX015C	AAPX015C	-	AOPX015C	-
CDAS HL 060	½"	AOPX020C	AAPX020C	-	AOPX020C	-
CDAS HL 065	½"	AOPX020C	AAPX020C	-	AOPX020C	-
CDAS HL 070	¾"	AOPX025D	AAPX025D	-	AOPX025D	-
CDAS HL 075	1"	AOPX025E	AAPX025E	-	AOPX025E	-
CDAS HL 080	1"	AOPX025E	AAPX025E	-	AOPX025E	-
CDAS HL 085	1 ½"	AOPX030G	AAPX030G	-	AOPX030G	-

Filtration Performance	General Purpose Pre-filter	High Efficiency Filter	Oil Vapour Reduction Filter	General Purpose Dry Particulate Filter	High Efficiency Dry Particulate Filter
Filtration Grade	Grade AO	Grade AA	-	Grade AO	-
Filtration Type	Coalescing	Coalescing	-	Dry Particulate	-
Particle Reduction (inc water & oil aerosols)	Down to 1 micron	Down to 0.01 micron	-	Down to 1 micron	-
Maximum Remaining Oil Aerosol Content at 21°C	≤0.5 mg/m³ (≤0.5 ppm(w))	≤0.01 mg/m³ (≤0.01 ppm(w))	-	N/A	-
Maximum Remaining Oil Vapour Content at System Temperature	N/A	N/A	-	N/A	-
Filtration Efficiency	99.925%	99.9999%	-	99.925%	-

Weights & Dimensions

Model	Pipe Size BSPP or NPT	Dimensions						Weight	
		Height (H)		Width (W)		Depth (D)		kg	lbs
		mm	ins	mm	ins	mm	ins		
CDAS HL 050	½"	1133	45	559	22	490	19	76	168
CDAS HL 055	½"	1313	52	559	22	490	19	84	185
CDAS HL 060	½"	1510	59	559	22	490	19	93	205
CDAS HL 065	½"	1660	65	559	22	490	19	100	220
CDAS HL 070	¾"	2020	80	559	22	490	19	120	265
CDAS HL 075	1"	1595	63	559	22	682	27	165	364
CDAS HL 080	1"	1745	69	559	22	682	27	180	397
CDAS HL 085	1 ½"	2105	83	559	22	682	27	210	463

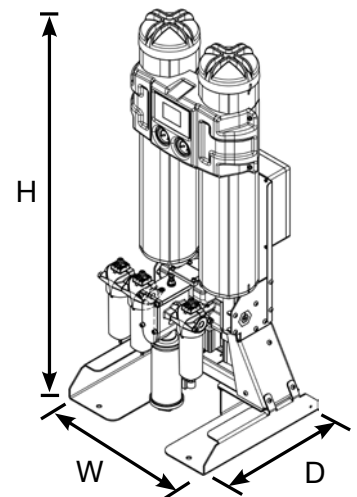

Quality Assurance / IP Rating / Pressure Vessel Approvals

Development / Manufacture	ISO 9001 / ISO 14001
Ingress Protection Rating	IP55 Indoor Use Only
EU	Pressure vessel approved for fluid group 2 in accordance with the Pressure Equipment Directive 2014/68/EU
USA	Approval to ASME VIII Div. 1 not required
AUS	Approval to AS1210 not required
GUS	TR (formerly GOST-R)
For use with Compressed Air Only	

Parker Worldwide

Europe, Middle East, Africa

AE – United Arab Emirates,

Dubai

Tel: +971 4 8127100

AT – Austria, St. Florian

Tel: +43 (0)7224 66201

AZ – Azerbaijan, Baku

Tel: +994 50 2233 458

BE/NL/LU – Benelux,

Hendrik Ido Ambacht

Tel: +31 (0)541 585 000

BY – Belarus, Minsk

Tel: +48 (0)22 573 24 00

CH – Switzerland, Etoy

Tel: +41 (0)21 821 87 00

CZ – Czech Republic,

Prague

Tel: +420 284 083 111

DE – Germany, Kaarst

Tel: +49 (0)2131 4016 0

DK – Denmark, Ballerup

Tel: +45 43 56 04 00

ES – Spain, Madrid

Tel: +34 902 330 001

FI – Finland, Vantaa

Tel: +358 (0)20 753 2500

FR – France, Contamine s/Arve

Tel: +33 (0)4 50 25 80 25

GR – Greece

Tel: +30 69 44 52 78 25

HU – Hungary, Budaörs

Tel: +36 23 885 470

IE – Ireland, Dublin

Tel: +353 (0)1 466 6370

IL – Israel

Tel: +39 02 45 19 21

IT – Italy, Corsico (MI)

Tel: +39 02 45 19 21

KZ – Kazakhstan, Almaty

Tel: +7 7273 561 000

NO – Norway, Asker

Tel: +47 66 75 34 00

PL – Poland, Warsaw

Tel: +48 (0)22 573 24 00

PT – Portugal

Tel: +351 22 999 7360

RO – Romania, Bucharest

Tel: +40 21 252 1382

RU – Russia, Moscow

Tel: +7 495 645-2156

SE – Sweden, Borås

Tel: +46 (0)8 59 79 50 00

SL – Slovenia, Novo Mesto

Tel: +386 7 337 6650

TR – Turkey, Istanbul

Tel: +90 216 4997081

UK – United Kingdom, Warwick

Tel: +44 (0)1926 317 878

ZA – South Africa, Kempton Park

Tel: +27 (0)11 961 0700

North America

CA – Canada, Milton, Ontario

Tel: +1 905 693 3000

US – USA, Cleveland

Tel: +1 216 896 3000

Asia Pacific

AU – Australia, Castle Hill

Tel: +61 (0)2-9634 7777

CN – China, Shanghai

Tel: +86 21 2899 5000

HK – Hong Kong

Tel: +852 2428 8008

IN – India, Mumbai

Tel: +91 22 6513 7081-85

JP – Japan, Tokyo

Tel: +81 (0)3 6408 3901

KR – South Korea, Seoul

Tel: +82 2 559 0400

MY – Malaysia, Shah Alam

Tel: +60 3 7849 0800

NZ – New Zealand, Mt Wellington

Tel: +64 9 574 1744

SG – Singapore

Tel: +65 6887 6300

TH – Thailand, Bangkok

Tel: +662 186 7000

TW – Taiwan, Taipei

Tel: +886 2 2298 8987

South America

AR – Argentina, Buenos Aires

Tel: +54 3327 44 4129

BR – Brazil, Sao Jose dos Campos

Tel: +55 080 0727 5374

CL – Chile, Santiago

Tel: +56 22 303 9640

MX – Mexico, Toluca

Tel: +52 72 2275 4200



EMEA Product Information Centre

Free phone: 00 800 27 27 5374

(from AT, BE, CH, CZ, DE, DK, EE, ES, FI, FR, IE, IL, IS, IT, LU, MT, NL, NO, PL, PT, RU, SE, SK, UK, ZA)

US Product Information Centre

Toll-free number: 1-800-27 27 537

www.parker.com/gsfe