



**Evolution Series
Technical Characteristics**

- Premium efficient motor
- High efficiency impeller
- Mountable in any position
- Maintenance free operation
- TEFC (IP55)

Optional Features

- Anodized aluminum components for corrosion resistance
- Increased sealing

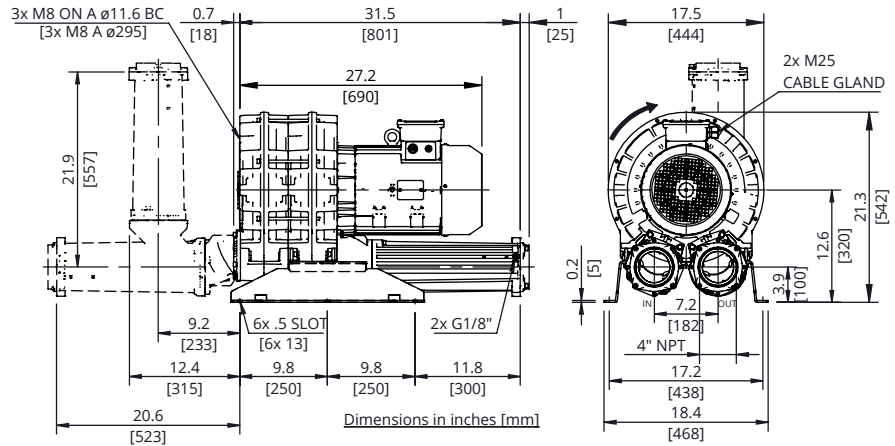

Technical Specifications

Model No.	HP	Hz	Open Flow (cfm)	Max Pressure in. H ₂ O	Max Vacuum in. H ₂ O	Efficiency	Voltage	FLA	Starting Current Ratio ¹	dB(A) ²	Weight (lb)
SCL e07-TS-7.5-3	7.5	60	582	30	30	89.5%	208-230/460	19.8-19.5/9.75	13.7	77.0	249.1
		50	491	60	60	89.2%	200/400	22.2/11.1		73.0	
SCL e07-TS-7.5-3-575	7.5	60	582	50	30	89.5%	575	7.21	13.5	77.0	249.1
SCL e07-TS-10-3	10	60	582	50	60	90.2%	208-230/460	26.1-25/12.5	13	77.0	260.1
		50	491	80	90	90.1%	200/400	28.6/14.3		73.0	
SCL e07-TS-10-3-575	10	60	582	50	60	90.2%	575	10	12.9	77.0	260.1
SCL e07-TS-15-3	15	60	582	100	110	91.0%	208-230/460	38.2-37.3/18.7	12.5	77.0	273.4
		50	491	130	-	91.0%	200/400	43.4 / 21.7		73.0	
SCL e07-TS-15-3-575	15	60	582	100	110	91.0%	575	13.9	11	77.0	273.4

Motors include normally closed thermal protector, 1.15 S.F. (60 Hz), tropicalized windings, Class F (B) insulation, and are suitable for use with a VFD (Contact FPZ for pneumatic and speed limits when used with a VFD).

¹Starting current ratio x fla = starting current

²Noise level measured at a distance of 1 m with inlet and outlet ports piped in accordance to ISO 3744

Data is subject to change without notice.

Recommended Accessories

Description	Pressure Safety Valve	Vacuum Safety Valve	Pressure Filter	Vacuum Filter	Check Valve
Part Number	VRL8 (15 HP) ³	VRL8 (15 HP) ³	FS-245P-400	CSL-2541P-400I	CV40
	VRL9 (5.5 HP - 10 HP) ³	VRL9 (5.5 HP-10 HP) ³			

³Valve selections are based on 60 Hz and standard air. Valves are supplied uncalibrated. Safety valves are easy to calibrate, but can be ordered with factory calibration.



PRESSURE

VACUUM

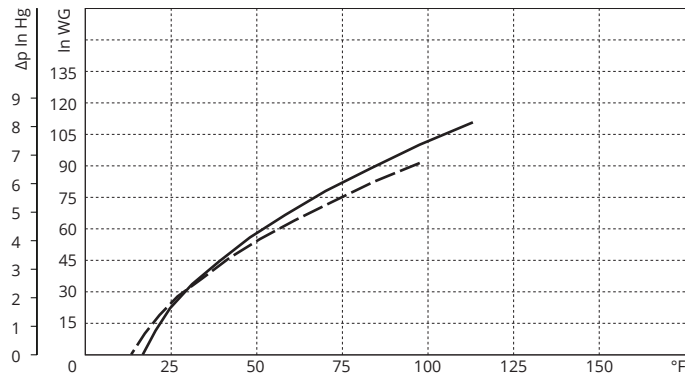
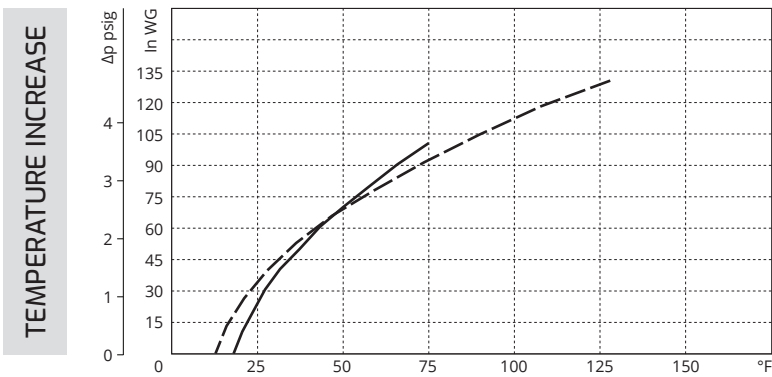
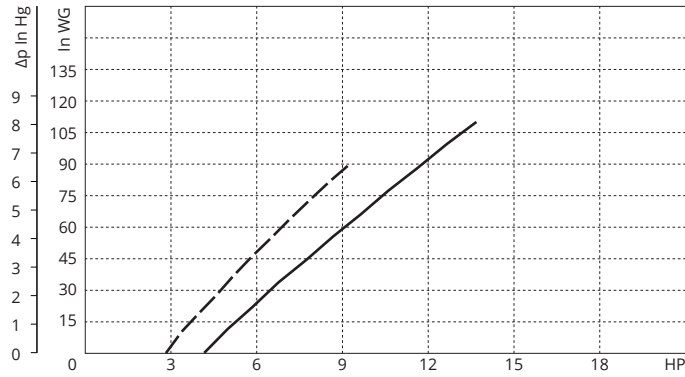
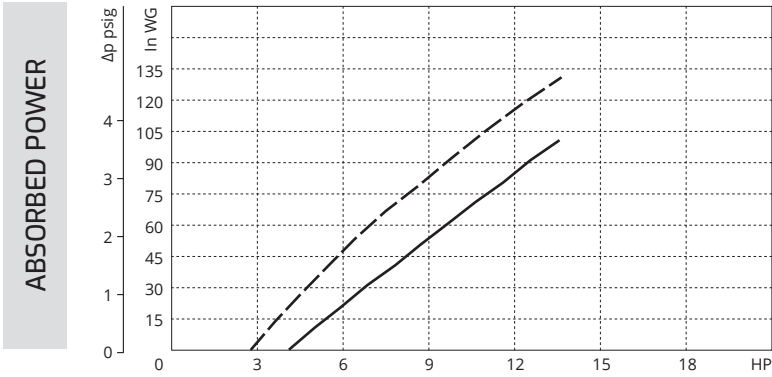
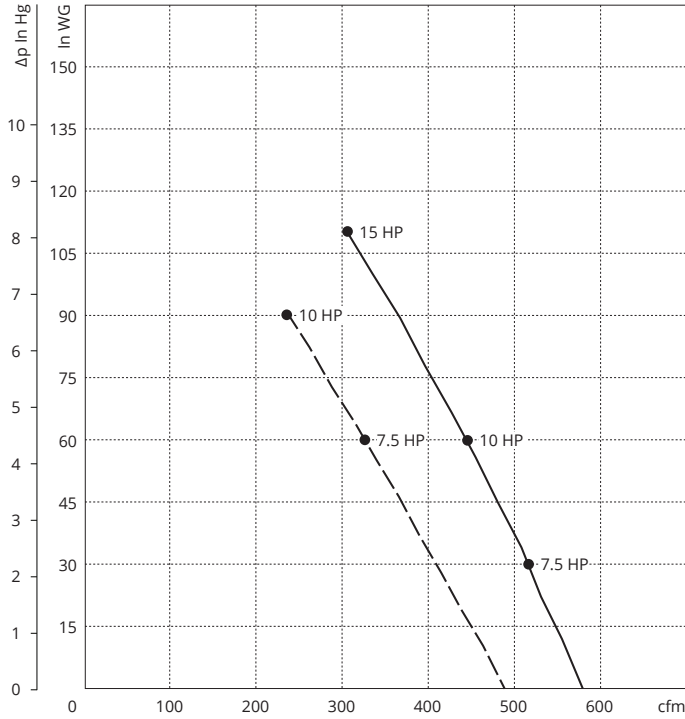
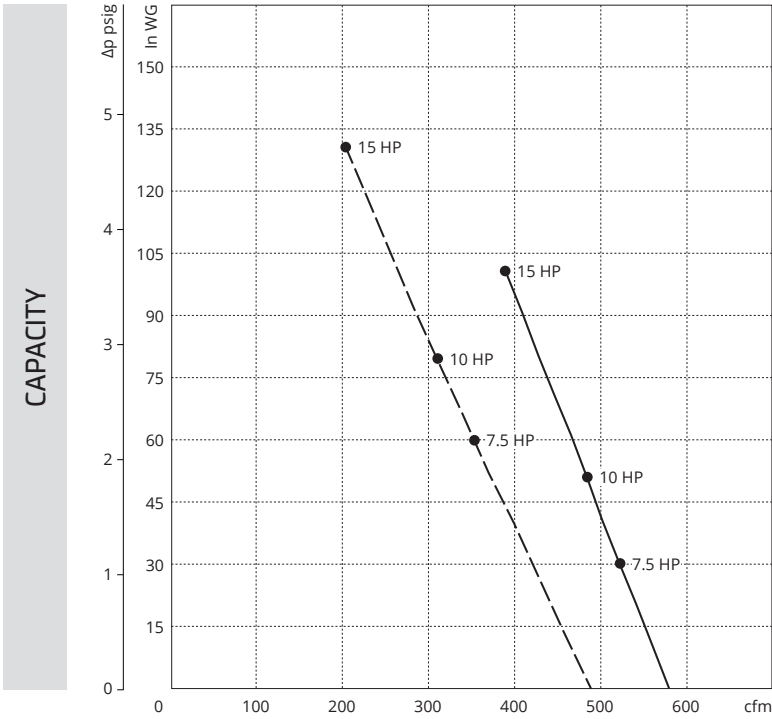

Curves refer to air at 68°F temperature and 29.92 In Hg atmospheric pressure (abs) measured at inlet port.
Values for flow, power consumption and temperature rise: +/-10% tolerance.
Data subject to change without notice.

KEY --- 50 Hz
 — 60 Hz

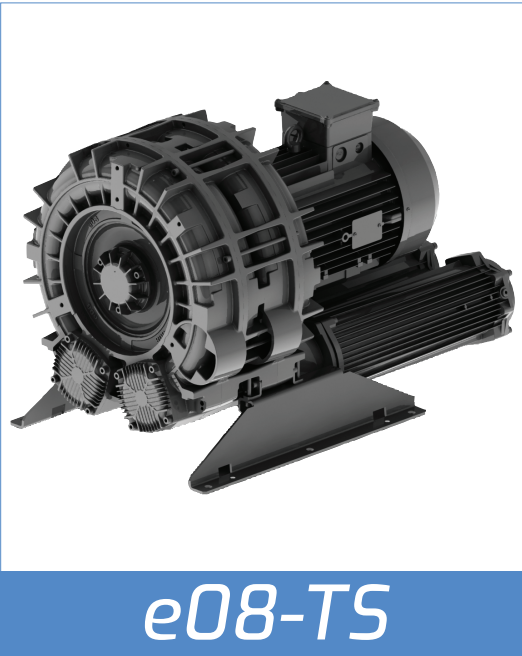

**Evolution Series
Technical Characteristics**

- Premium efficient motor
- High efficiency impeller
- Mountable in any position
- Maintenance free operation
- TEFC (IP55)

Optional Features

- Anodized aluminum components for corrosion resistance
- Increased sealing

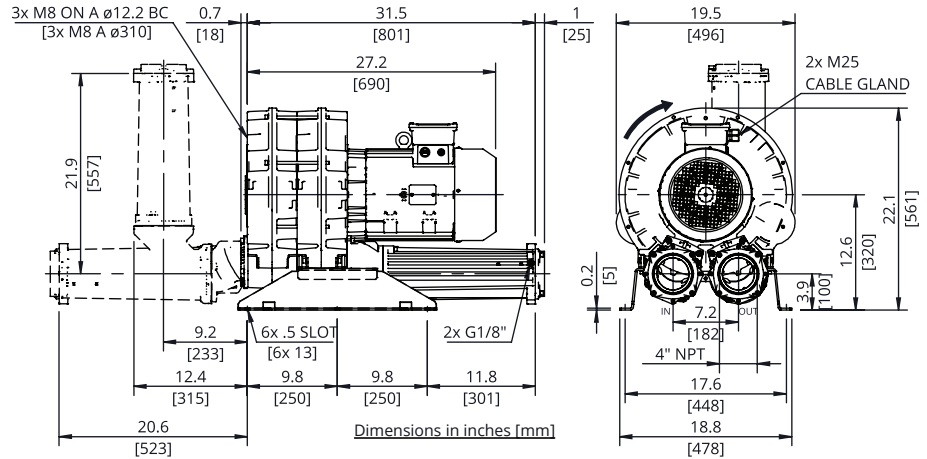

Technical Specifications

Model No.	HP	Hz	Open Flow (cfm)	Max Pressure in. H ₂ O	Max Vacuum in. H ₂ O	Efficiency	Voltage	FLA	Starting Current Ratio ¹	dB(A) ²	Weight (lb)
SCL e08-TS-15-3	15	60	712	60	60	91.0%	208-230/460	38.2-37.3/18.7	12.5	83.3	293.2
		50	593	90	90	91.2%	200/400	43.4/21.7		81.3	
SCL e08-TS-15-3-575	15	60	712	60	60	91.0%	575	13.9	11	83.3	293.2

Motors include normally closed thermal protector, 1.15 S.F. (60 Hz), tropicalized, Class F (B) insulation, and are suitable for use with VFD (Contact FPZ for pneumatic and speed limits when used with a VFD).

¹Starting current ratio x fla = starting current

²Noise level measured at a distance of 1 m with inlet and outlet ports piped in accordance to ISO 3744

Data is subject to change without notice.

Recommended Accessories

Description	Pressure Safety Valve	Vacuum Safety Valve	Pressure Filter	Vacuum Filter	Check Valve
Part Number	VRL9 ³	VRL9 ³	FS-245P-400	CSL-2541-400I	CV40

³Valve selections are based on 60 Hz and standard air. Valves are supplied uncalibrated. Safety valves are easy to calibrate, but can be ordered with factory calibration.



PRESSURE

VACUUM

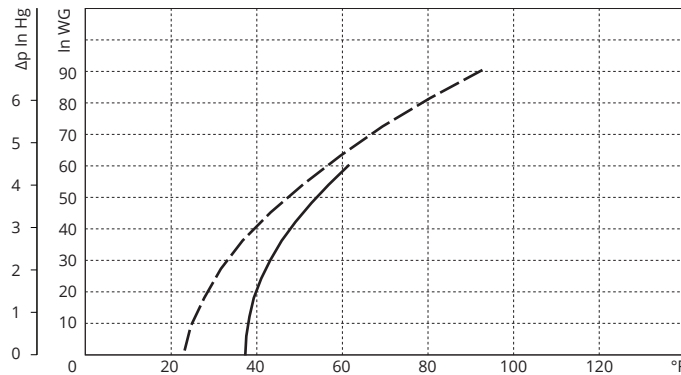
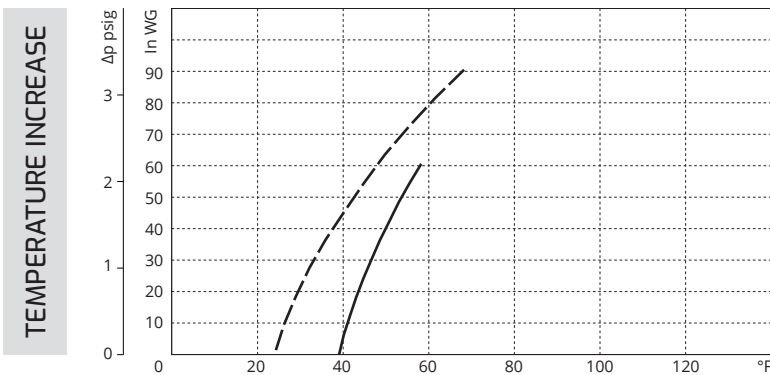
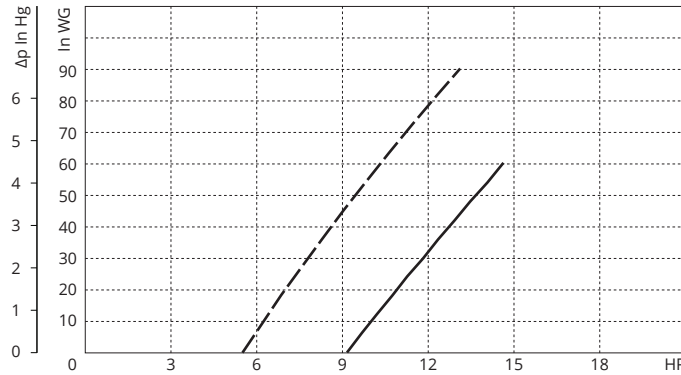
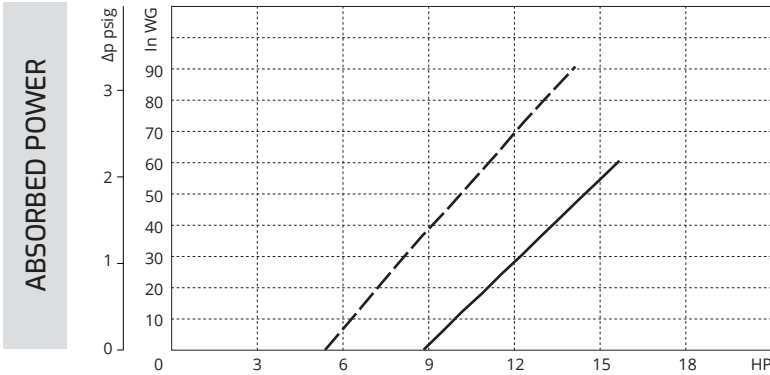
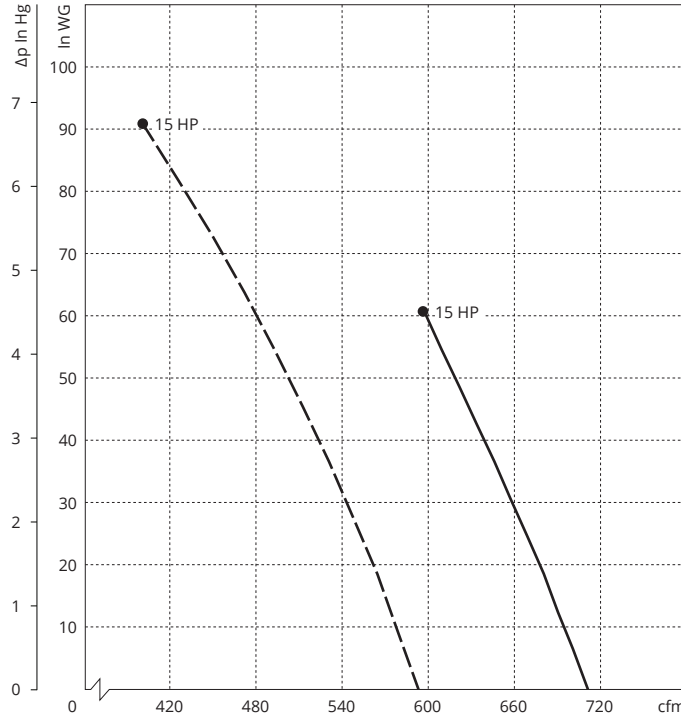
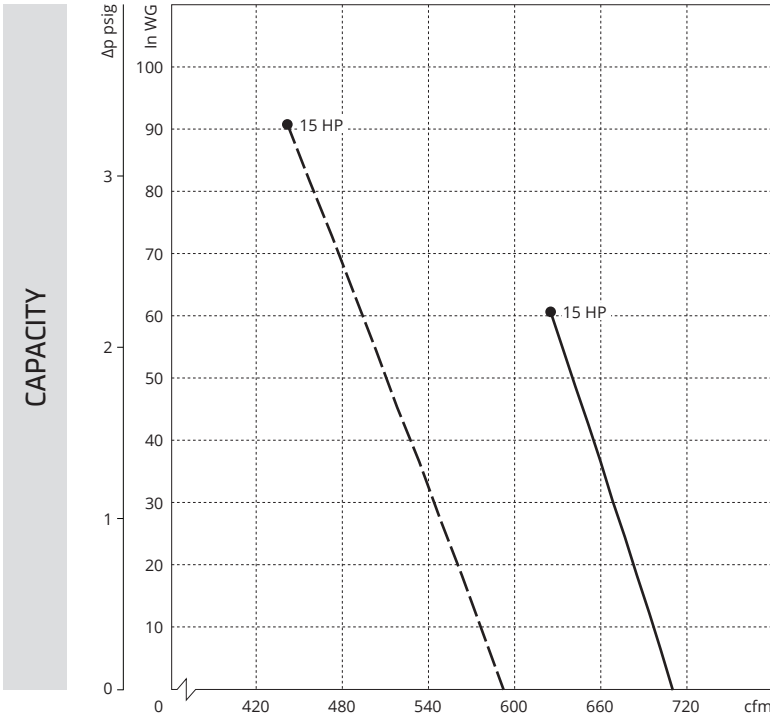

Curves refer to air at 68°F temperature and 29.92 In Hg atmospheric pressure (abs) measured at inlet port. Values for flow, power consumption and temperature rise: +/-10% tolerance. Data subject to change without notice.

KEY

- 50 Hz
- 60 Hz



**Evolution Series
Technical Characteristics**

- Premium efficient motor
- High efficiency impeller
- Mountable in any position
- Maintenance free operation
- TEFC (IP55)

Optional Features

- Anodized aluminum components for corrosion resistance
- Increased sealing

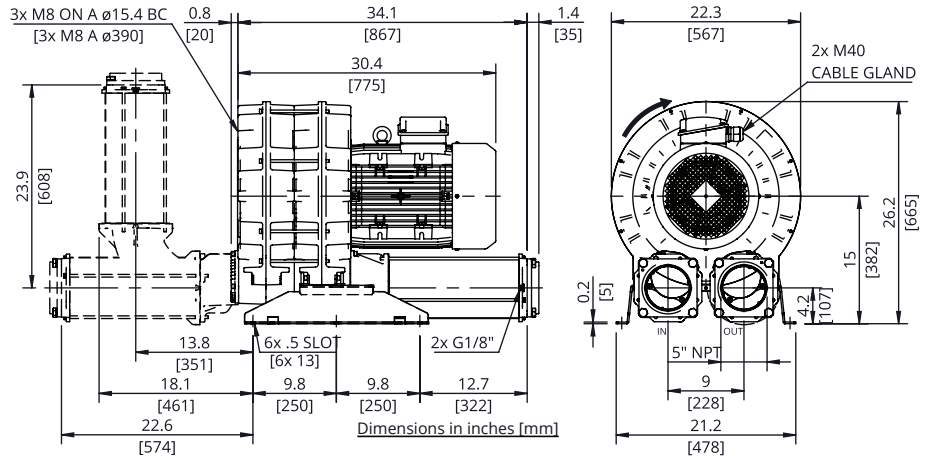

Technical Specifications

Model No.	HP	Hz	Open Flow (cfm)	Max Pressure in. H ₂ O	Max Vacuum in. H ₂ O	Efficiency	Voltage	FLA	Starting Current Ratio ¹	dB(A) ²	Weight (lb)
SCL e11-TS-25-3	25	60	1304	50	50	91.7%	208-230/460	62 / 31	12.5	86	463.0
		50	1092	90	100	92.4%	200/400	69 / 34.5		82	
SCL e11-TS-25-3-575	25	60	1304	50	50	91.7%	575	24.8	12.5	86	463.0
SCL e11-TS-30-3	30	60	1304	70	70	91.7%	208-230/460	71.6 / 35.8	10.6	86	489.4
		50	1092	110	110	92.7%	200/400	77.8 / 38.9		82	
SCL e11-TS-30-3-575	30	60	1304	70	70	91.7%	575	28.6	10.6	86	489.4

Motors include normally closed thermal protector, 1.15 S.F. (60 Hz), tropicalized windings, Class F (B) insulation, and are suitable for use with a VFD (Contact FPZ for pneumatic and speed limits when used with a VFD).

¹Starting current ratio x fla = starting current

²Noise level measured at a distance of 1 m with inlet and outlet ports piped in accordance to ISO 3744

Data is subject to change without notice.

Recommended Accessories

Description	Pressure Safety Valve	Vacuum Safety Valve	Pressure Filter	Vacuum Filter	Check Valve
Part number	(2) VRL9 (25 HP) ³	(2) VRL9 (25 HP) ³	FL10	CTD-375P-500C	CV5-502M-1330
	(2) VRL9 (30 HP) ³	(2) VRL9 (30 HP) ³			

³Valve selections are based on 60 Hz and standard air. Valves are supplied uncalibrated. Safety valves are easy to calibrate, but can be ordered with factory calibration.



PRESSURE

VACUUM

CAPACITY

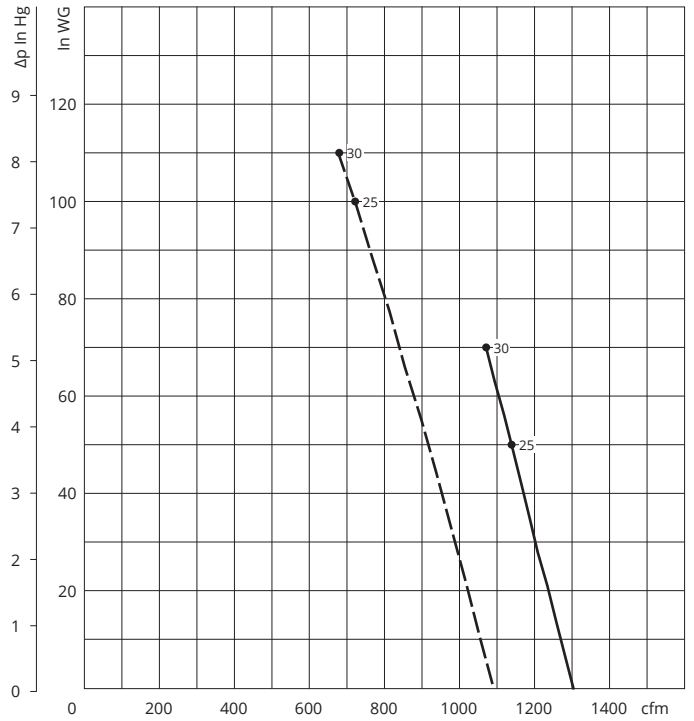
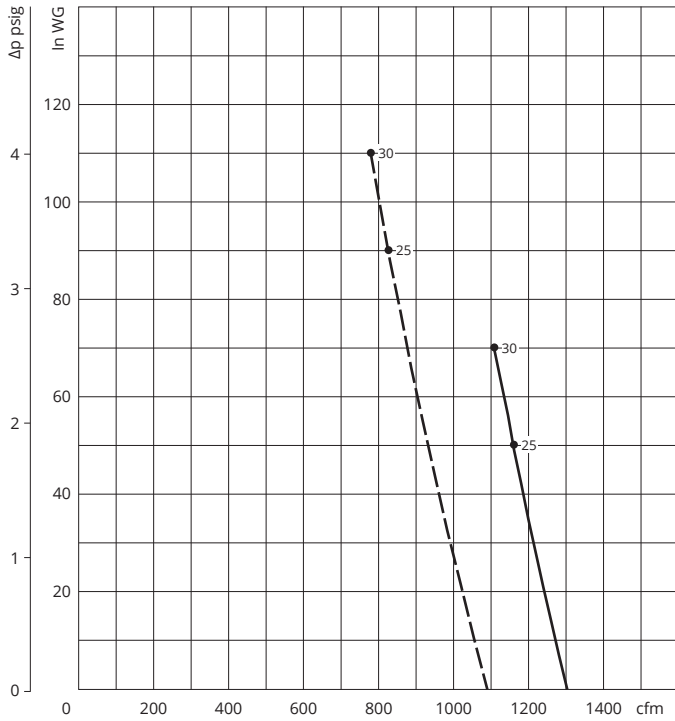

ABSORBED POWER

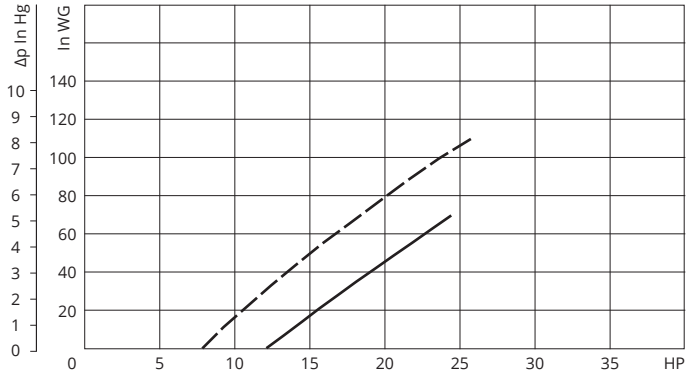
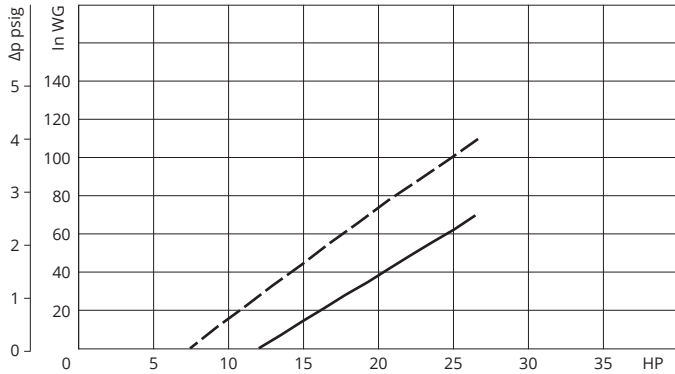

TEMPERATURE INCREASE

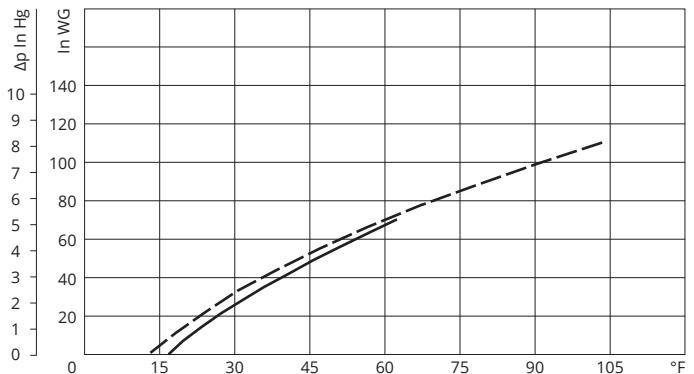
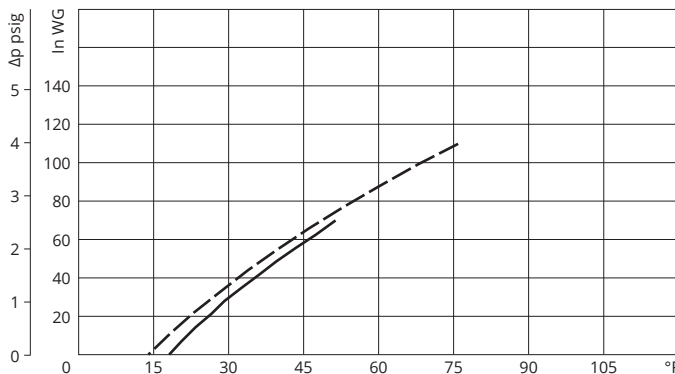

Curves refer to air at 68°F temperature and 29.92 In Hg atmospheric pressure (abs) measured at inlet port. Values for flow, power consumption and temperature rise: +/-10% tolerance. Data subject to change without notice.

KEY - - - 50 Hz
 — — — 60 Hz



e12-TS

**Evolution Series
Technical Characteristics**

- Premium efficient motor
- High efficiency impeller
- Mountable in any position
- Maintenance free operation
- TEFC (IP55)

Optional Features

- Anodized aluminum components for corrosion resistance
- Increased sealing

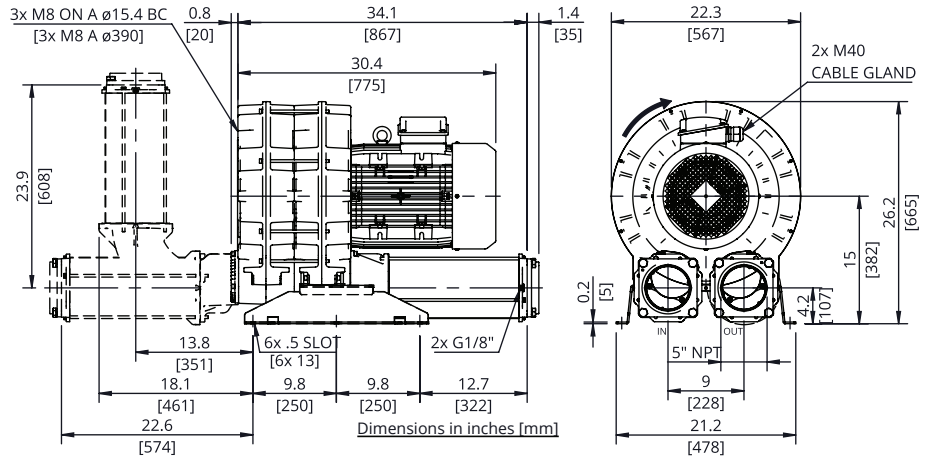

Technical Specifications

Model No.	HP	Hz	Open Flow (cfm)	Max Pressure in. H ₂ O	Max Vacuum in. H ₂ O	Efficiency	Voltage	FLA	Starting Current Ratio ¹	dB(A) ²	Weight (lb)
SCL e12-TS-30-3	30	60	1492	70	70	91.7%	460	71.6/35.8	12.5	88	493.8
		50	1238	100	100	92.7%	400	77.8/38.9	12.5	84	493.8
SCL e12-TS-30-3-575	30	60	1492	70	70	91.7%	575	28.6	10.6	88	493.8

Motors include normally closed thermal protector, 1.15 S.F. (60 Hz), tropicalized windings, Class F (B) insulation, and are suitable for use with a VFD (Contact FPZ for pneumatic and speed limits when used with a VFD).

¹Starting current ratio x fla = starting current

²Noise level measured at a distance of 1 m with inlet and outlet ports piped in accordance to ISO 3744

Data is subject to change without notice.

Recommended Accessories

Description	Pressure Safety Valve	Vacuum Safety Valve	Pressure Filter	Vacuum Filter	Check Valve
Part number	(2) VRL9 (30 HP) ³	(2) VRL9 (30 HP) ³	FL10	CTD-375P-500C	CV5-502M-1330

³Valve selections are based on 60 Hz and standard air. Valves are supplied uncalibrated. Safety valves are easy to calibrate, but can be ordered with factory calibration.



PRESSURE

VACUUM

CAPACITY

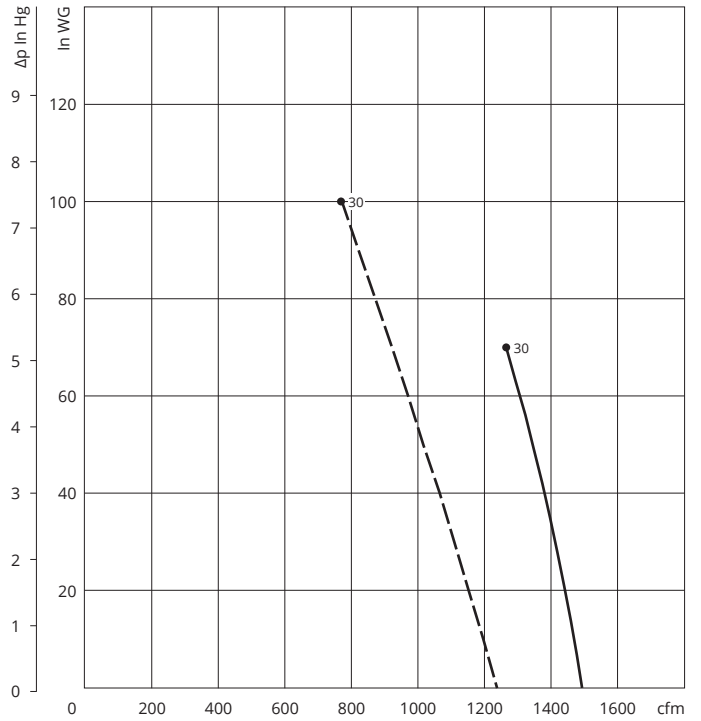
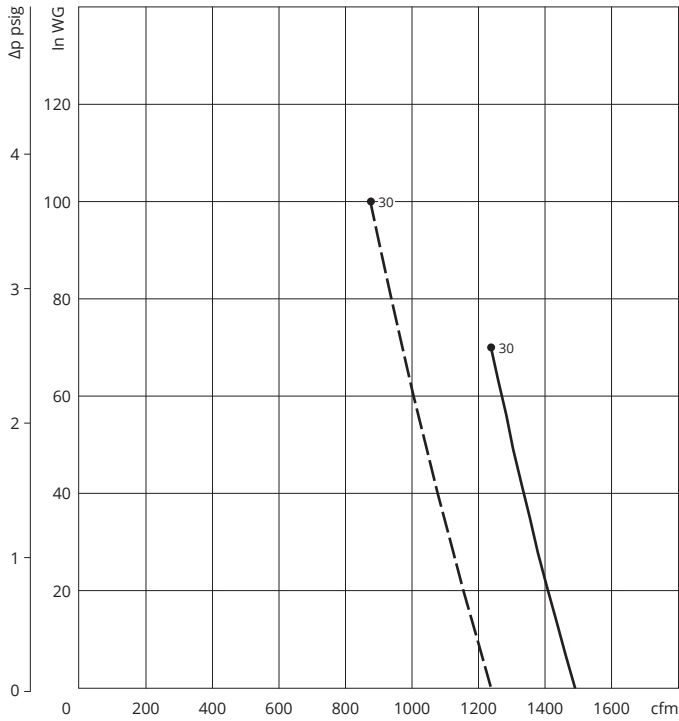

ABSORBED POWER

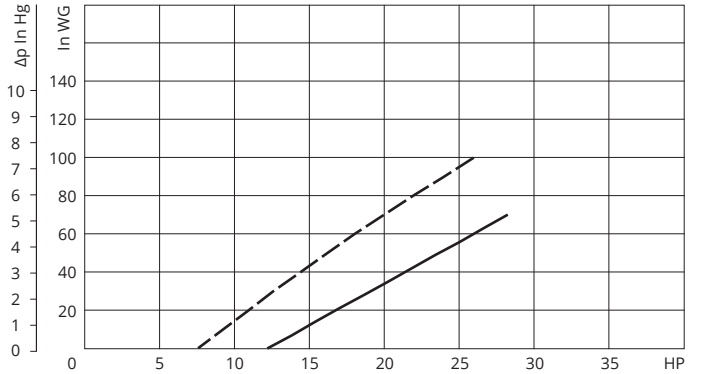
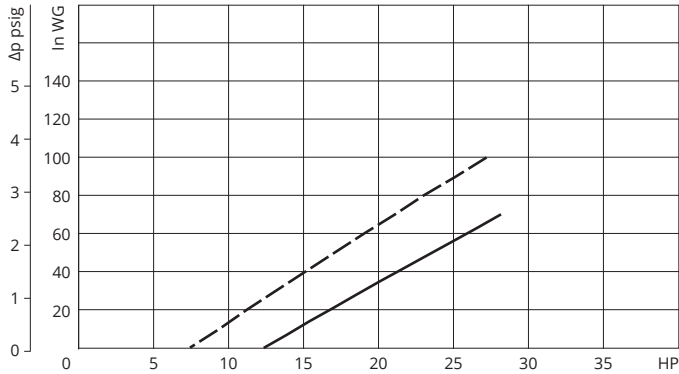

TEMPERATURE INCREASE

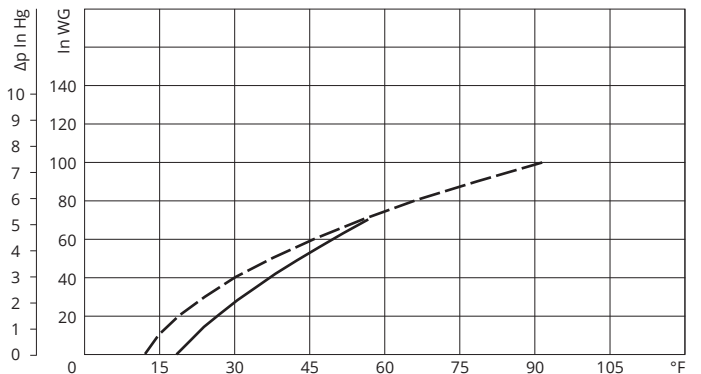
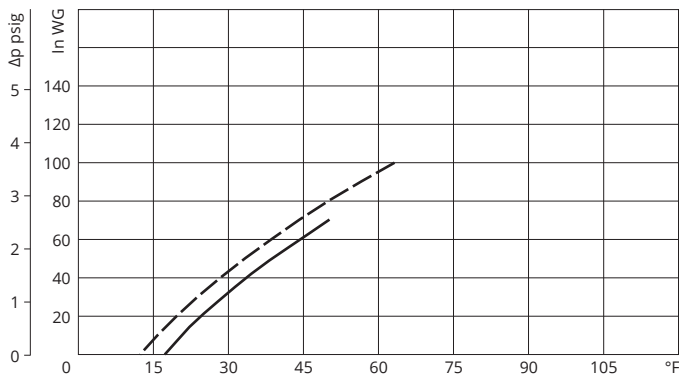

Curves refer to air at 68°F temperature and 29.92 In Hg atmospheric pressure (abs) measured at inlet port.
Values for flow, power consumption and temperature rise: +/-10% tolerance.
Data subject to change without notice.

KEY --- 50 Hz
 — 60 Hz

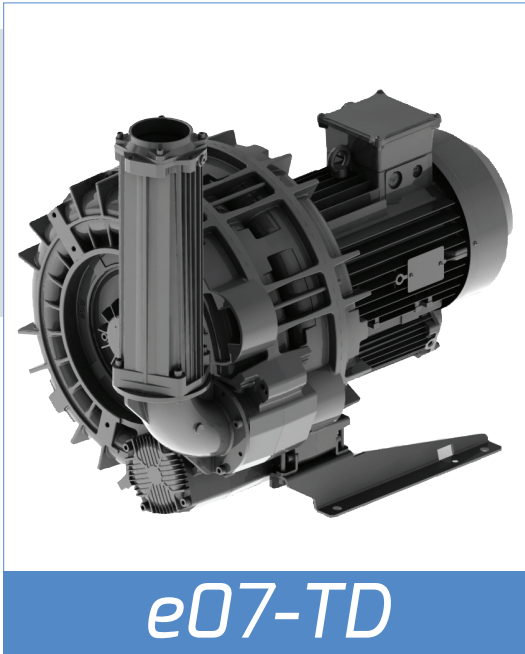

**Evolution Series
Technical Characteristics**

- Premium efficient motor
- High efficiency impeller
- Mountable in any position
- Maintenance free operation
- TEFC (IP55)

Optional Features

- Anodized aluminum components for corrosion resistance
- Increased sealing

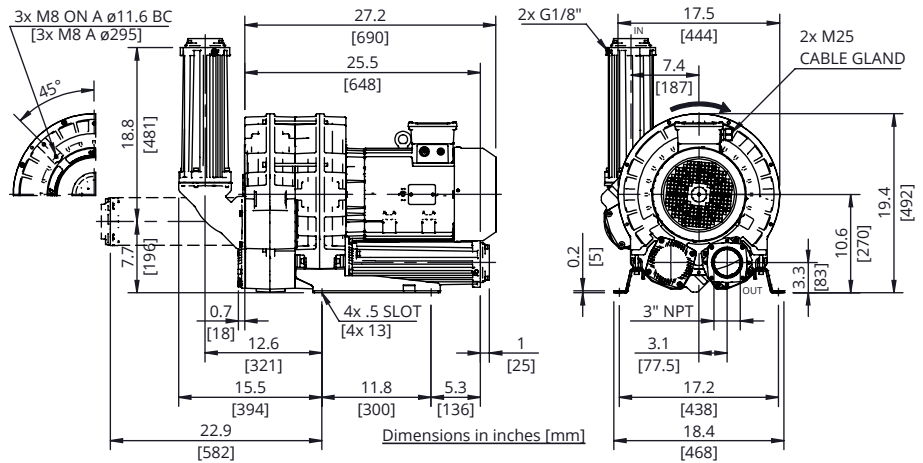

Technical Specifications

Model No.	HP	Hz	Open Flow (cfm)	Max Pressure in. H ₂ O	Max Vacuum in. H ₂ O	Efficiency	Voltage	FLA	Starting Current Ratio ¹	dB(A) ²	Weight (lb)
SCL e07-TD-15-3	15	60	304	220	170	91.0%	208-230/460	38.2-37.3/18.7	12.5	77.0	262.3
		50	255	220	160	91.2%	200/400	43.4/21.7		74.0	
SCL e07-TD-15-3-575	15	60	304	220	170	91.0%	575	13.9	11	77.0	262.3

Motors include normally closed thermal protector, 1.15 S.F. (60 Hz), tropicalized, Class F (B) insulation, and are suitable for use with VFD (Contact FPZ for pneumatic and speed limits when used with a VFD).

¹Starting current ratio x fla = starting current

²Noise level measured at a distance of 1 m with inlet and outlet ports piped in accordance to ISO 3744

Data is subject to change without notice.

Recommended Accessories

Description	Pressure Safety Valve	Vacuum Safety Valve	Pressure Filter	Vacuum Filter	Check Valve
Part Number	VRL6 ³	VRL6 ³	FS-235P-300	CT-235P-300C	CV30

³Valve selections are based on 60 Hz and standard air. Valves are supplied uncalibrated. Safety valves are easy to calibrate, but can be ordered with factory calibration.



PRESSURE

VACUUM

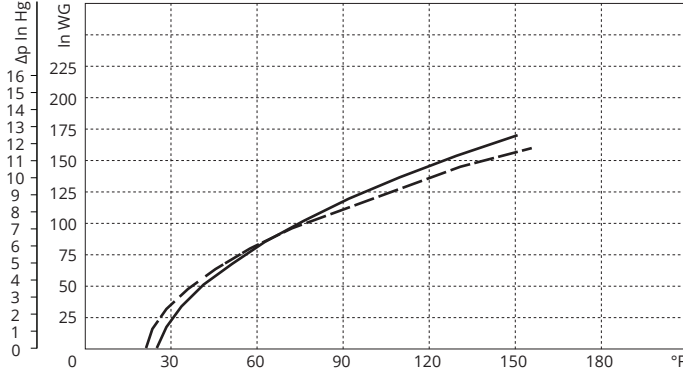
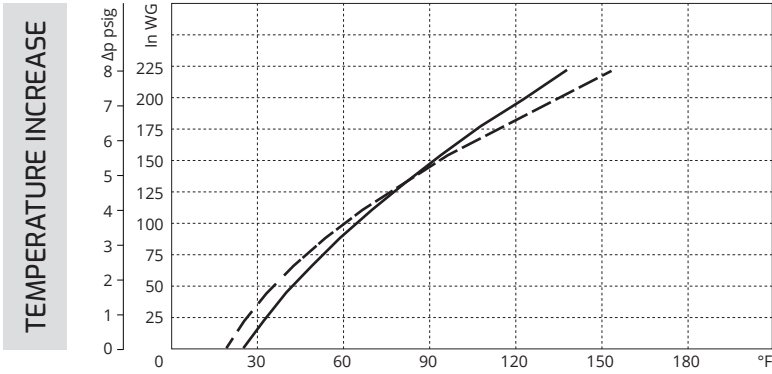
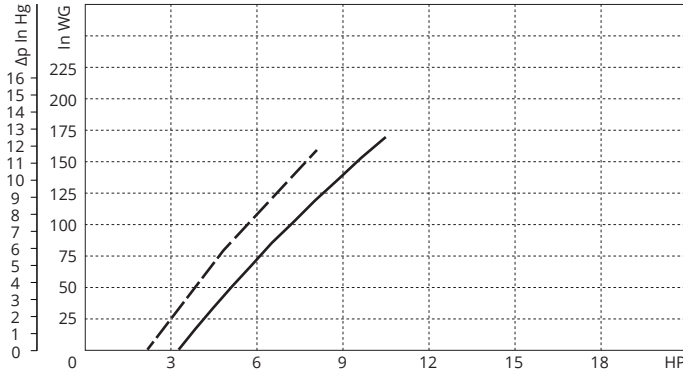
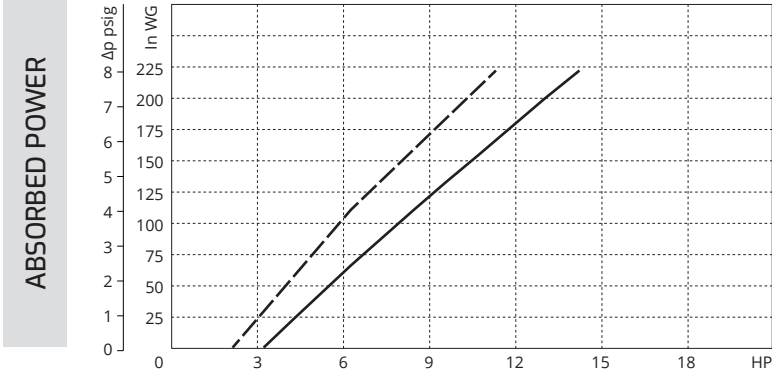
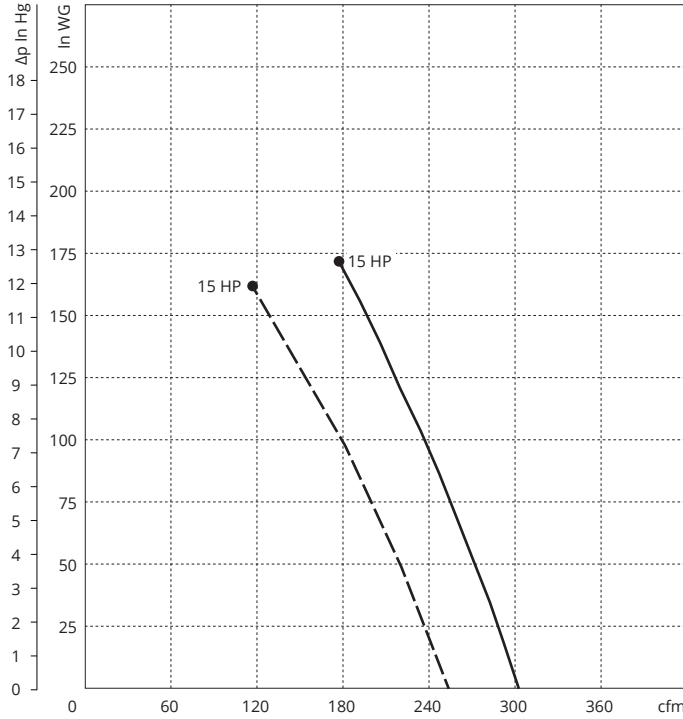
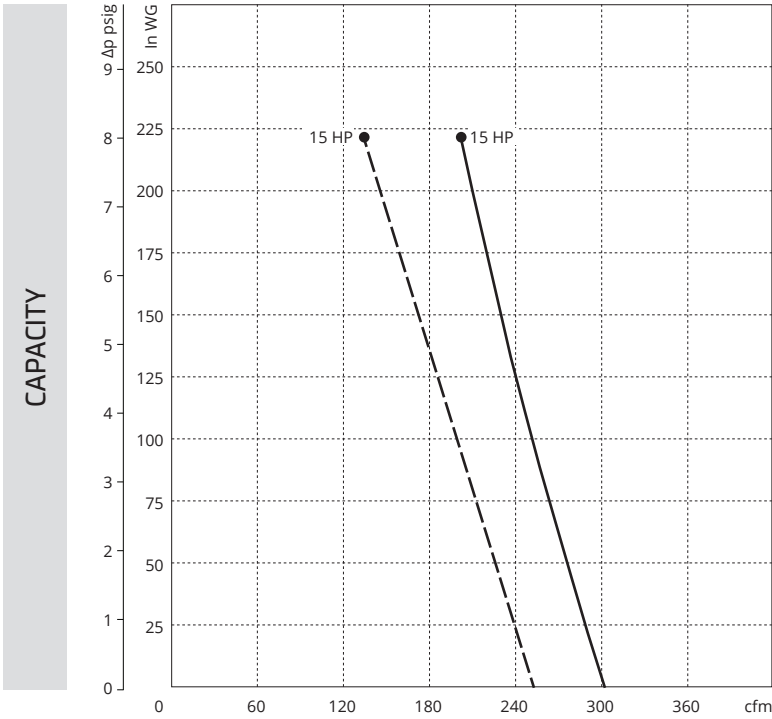

Curves refer to air at 68°F temperature and 29.92 In Hg atmospheric pressure (abs) measured at inlet port.
Values for flow, power consumption and temperature rise: +/-10% tolerance.
Data subject to change without notice.

KEY --- 50 Hz
 — 60 Hz



**Evolution Series
Technical Characteristics**

- Premium efficient motor
- High efficiency impeller
- Mountable in any position
- Maintenance free operation
- TEFC (IP55)

Optional Features

- Anodized aluminum components for corrosion resistance
- Increased sealing

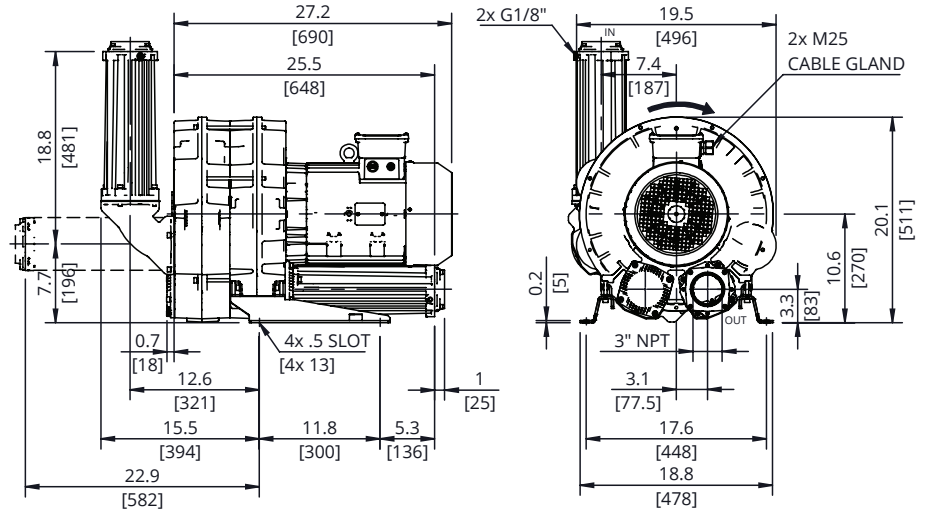

e08-TD

Technical Specifications

Model No.	HP	Hz	Open Flow (cfm)	Max Pressure in. H ₂ O	Max Vacuum in. H ₂ O	Efficiency	Voltage	FLA	Starting Current Ratio ¹	dB(A) ²	Weight (lb)
SCL e08-TD-15-3	15	60	406	160	170	91.0%	208-230/460	38.2-37.3/18.7	12.5	81.5	277.8
		50	340	220	170	91.2%	200/400	43.4/21.7		79.5	
SCL e08-TD-15-3-575	15	60	406	160	170	91.0%	575	13.9	11	81.5	277.8

Motors include normally closed thermal protector, 1.15 S.F. (60 Hz), tropicalized, Class F (B) insulation, and are suitable for use with VFD (Contact FPZ for pneumatic and speed limits when used with a VFD).

¹Starting current ratio x fla = starting current

²Noise level measured at a distance of 1 m with inlet and outlet ports piped in accordance to ISO 3744

Data is subject to change without notice.

Recommended Accessories

Description	Pressure Safety Valve	Vacuum Safety Valve	Pressure Filter	Vacuum Filter	Check Valve
Part Number	VRL6 ³	VRL6 ³	FS-235P-300	CT-235P-300C	CV30

³Valve selections are based on 60 Hz and standard air. Valves are supplied uncalibrated. Safety valves are easy to calibrate, but can be ordered with factory calibration.



PRESSURE

VACUUM

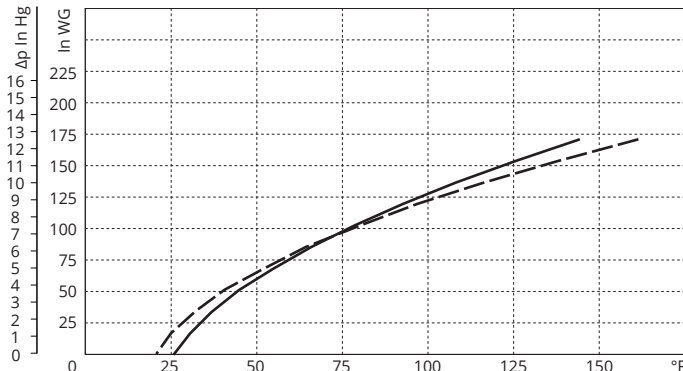
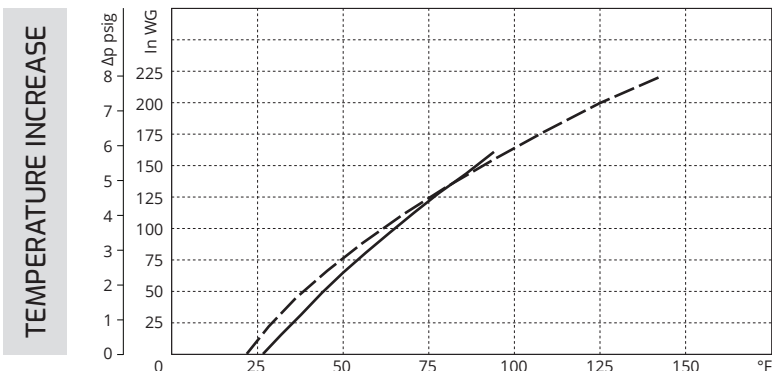
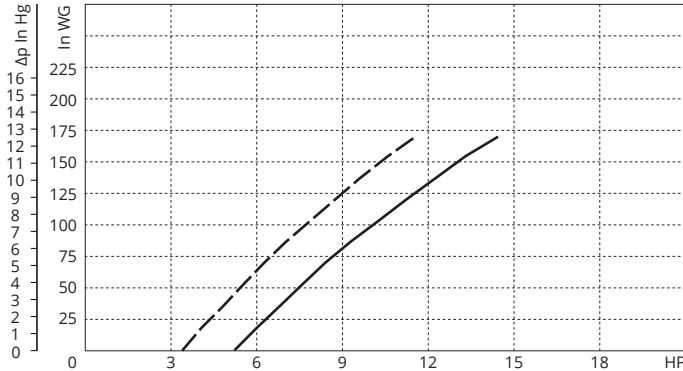
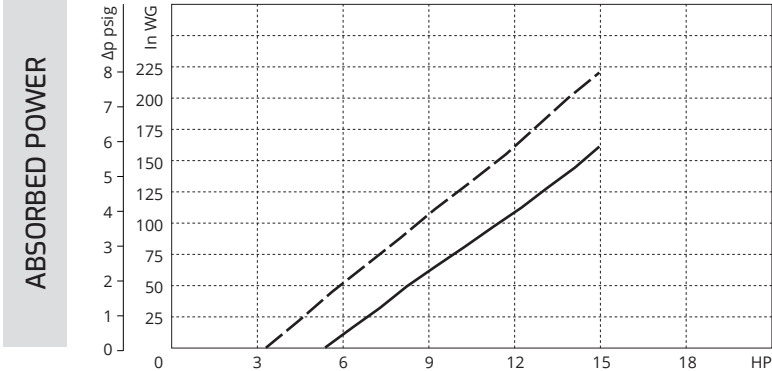
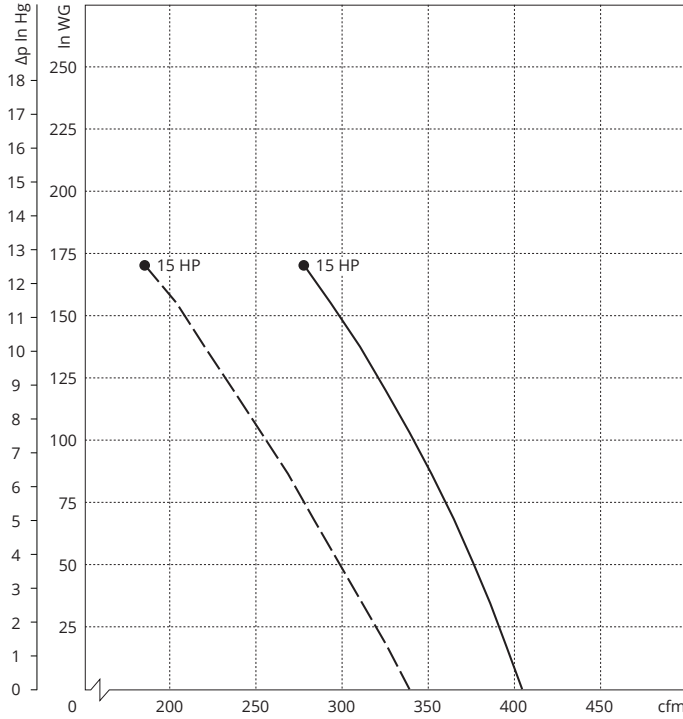
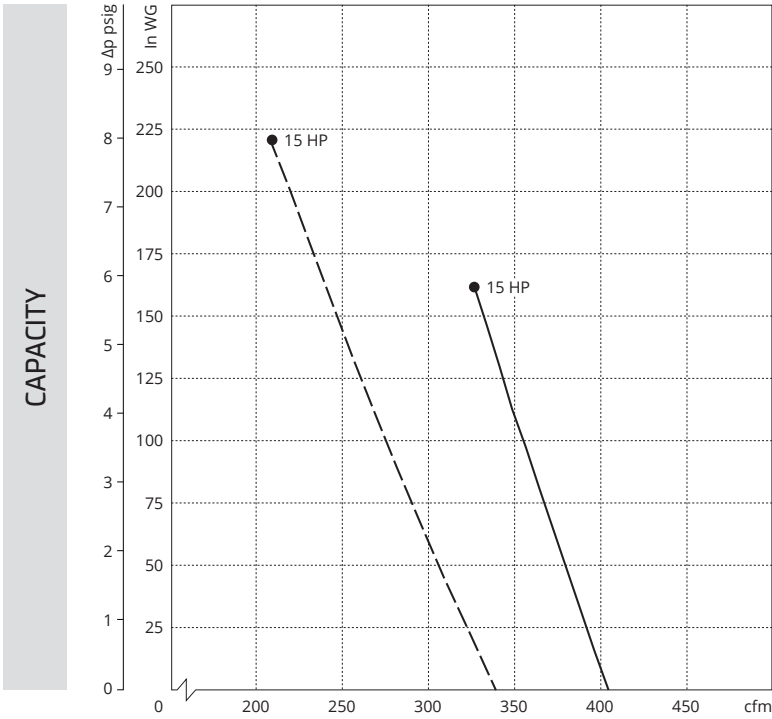

Curves refer to air at 68°F temperature and 29.92 In Hg atmospheric pressure (abs) measured at inlet port.
 Values for flow, power consumption and temperature rise: +/-10% tolerance.
 Data subject to change without notice.

KEY --- 50 Hz
 ——— 60 Hz