

ZONE		REV	DESCRIPTION	CHG BY	CHK BY	APP BY	REL BY	DATE
-	A		CHANGED FILTER PACKAGES.	SDM	DEH	DEH	SDM	10/16/06
-	B		REMOVED UNNEEDED DETAIL A	DL	DEH	DEH	SDM	2/16/07
-	C		CHANGED ELECTRICAL PANEL & VALVE	CPG	DEH	DEH	SDM	03/11/10
B-4	D		ADDED SINGLE PROBE DUAL RTD/THERMOCOUPLE	SOM/BEC	KL	DEH	SOM/BEC	05/31/19

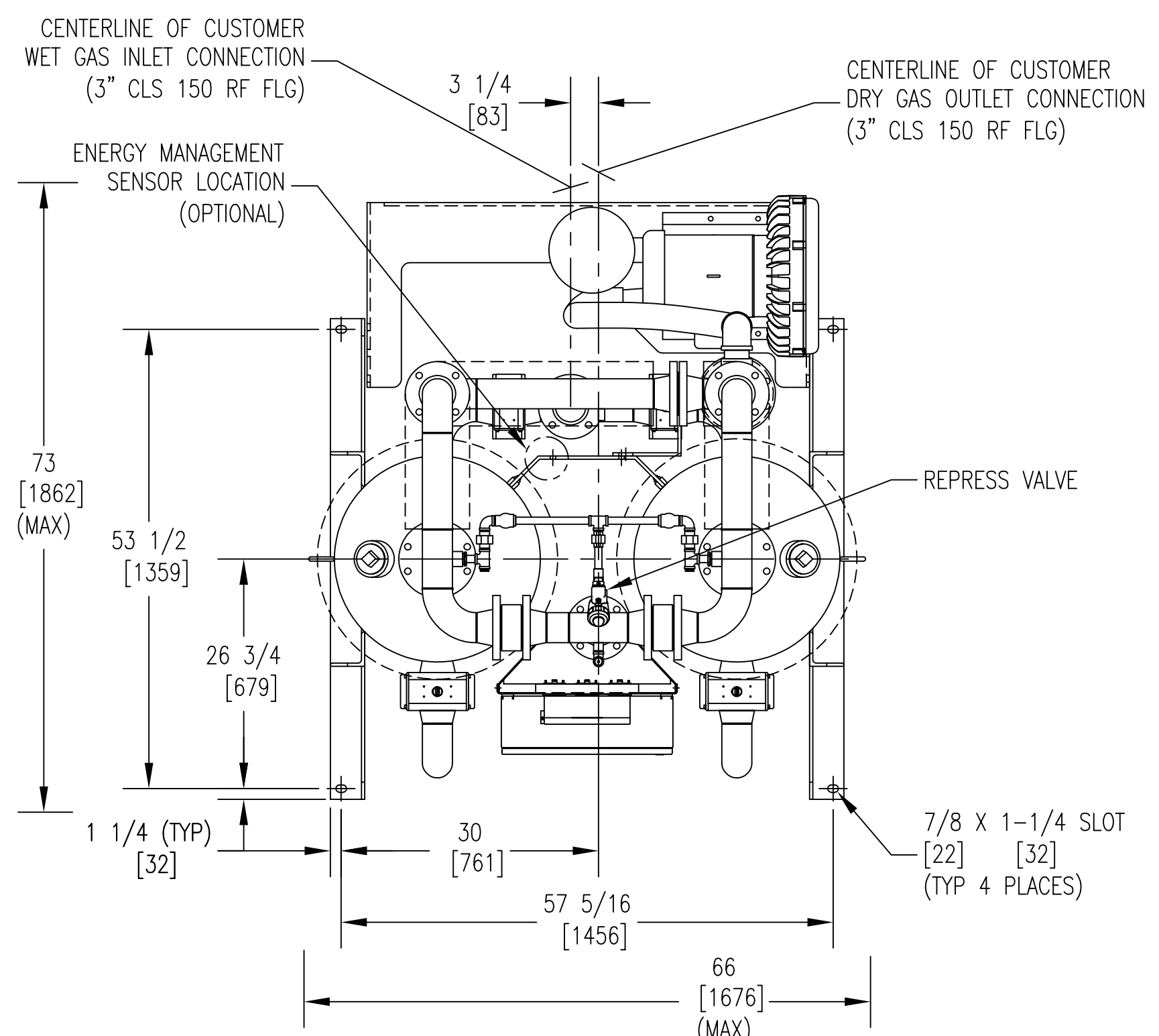

TOP VIEW

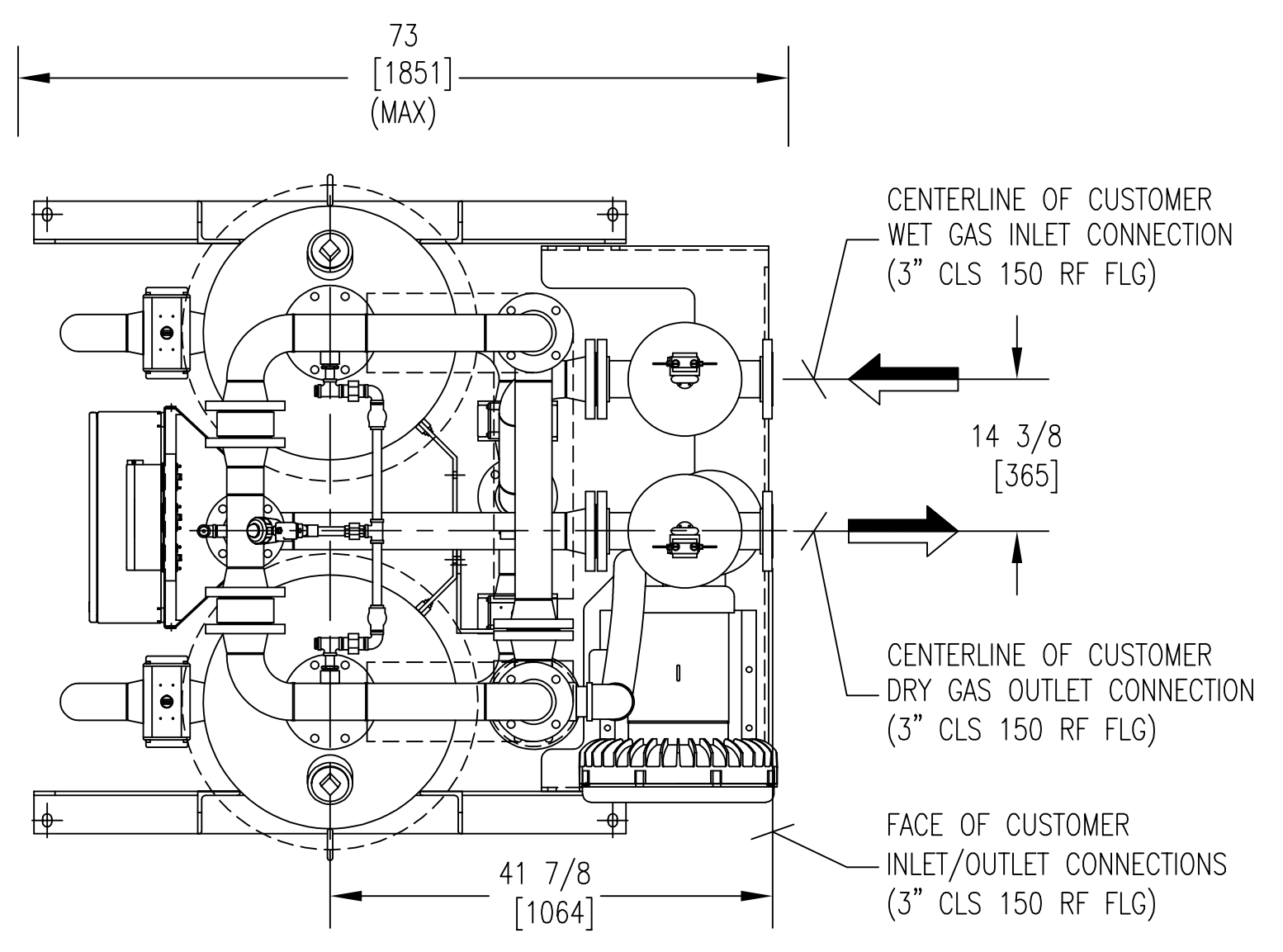

TOP VIEW (F01 PKG OPTIONAL)

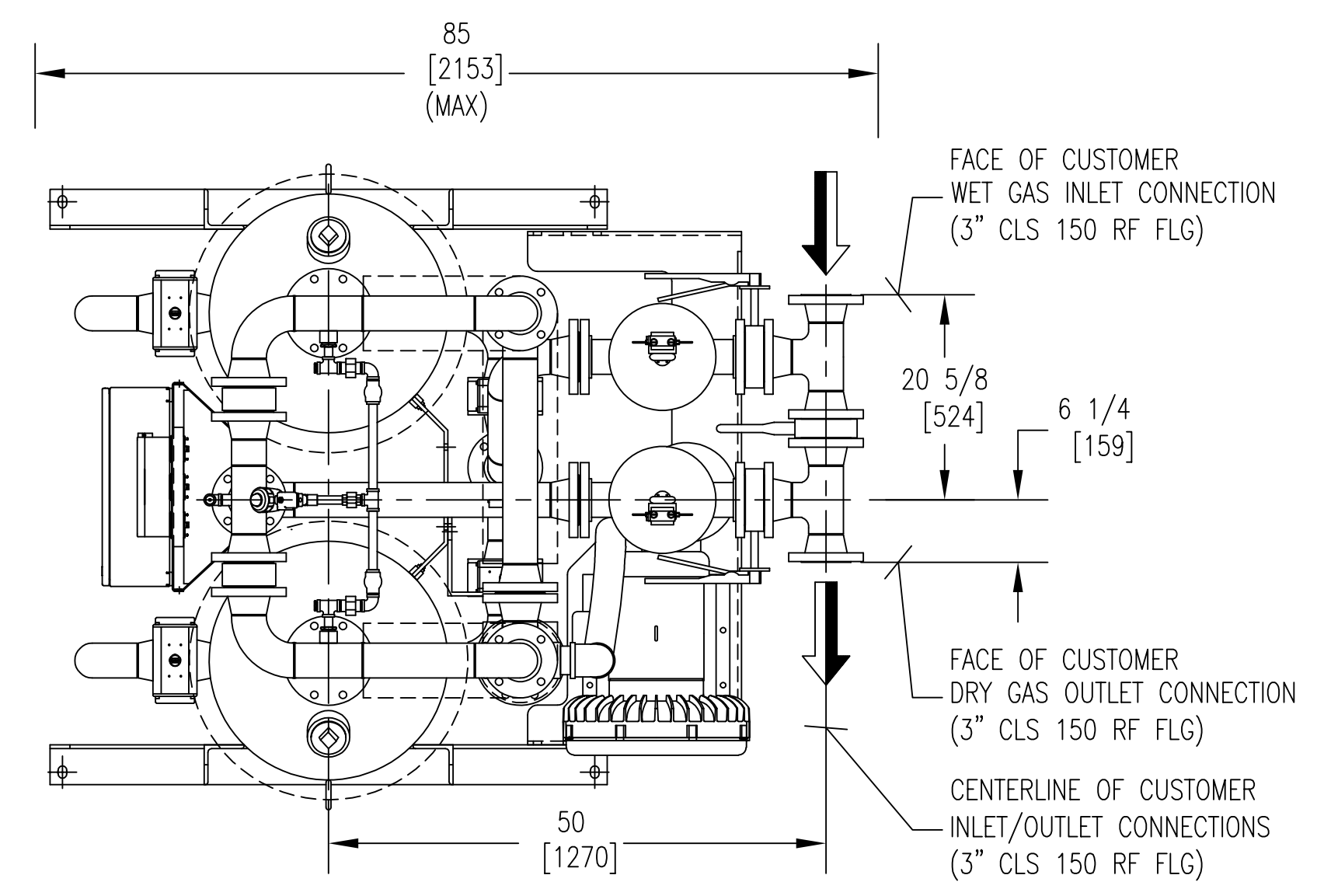

TOP VIEW (F02 PKG OPTIONAL)

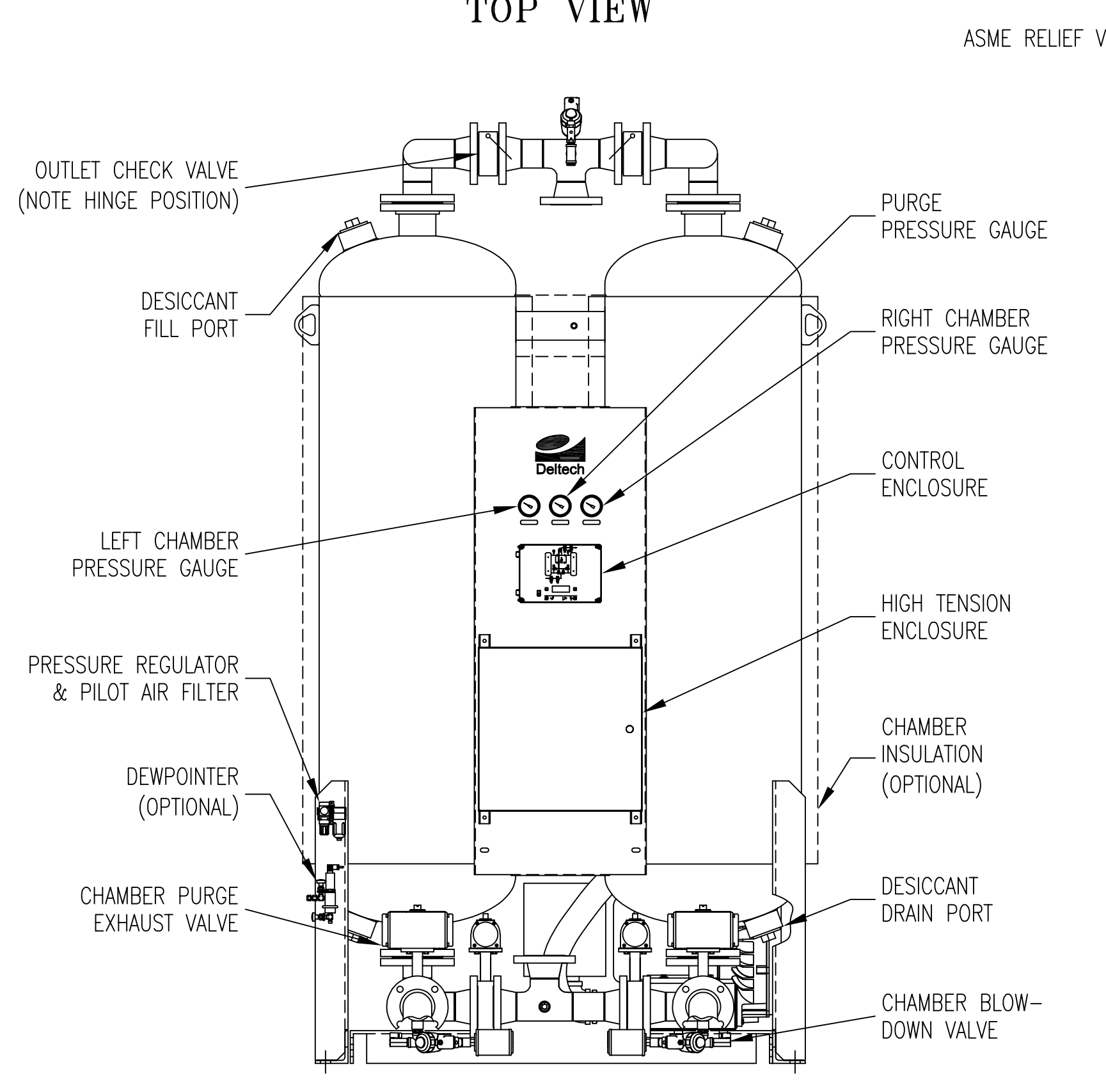

FRONT VIEW

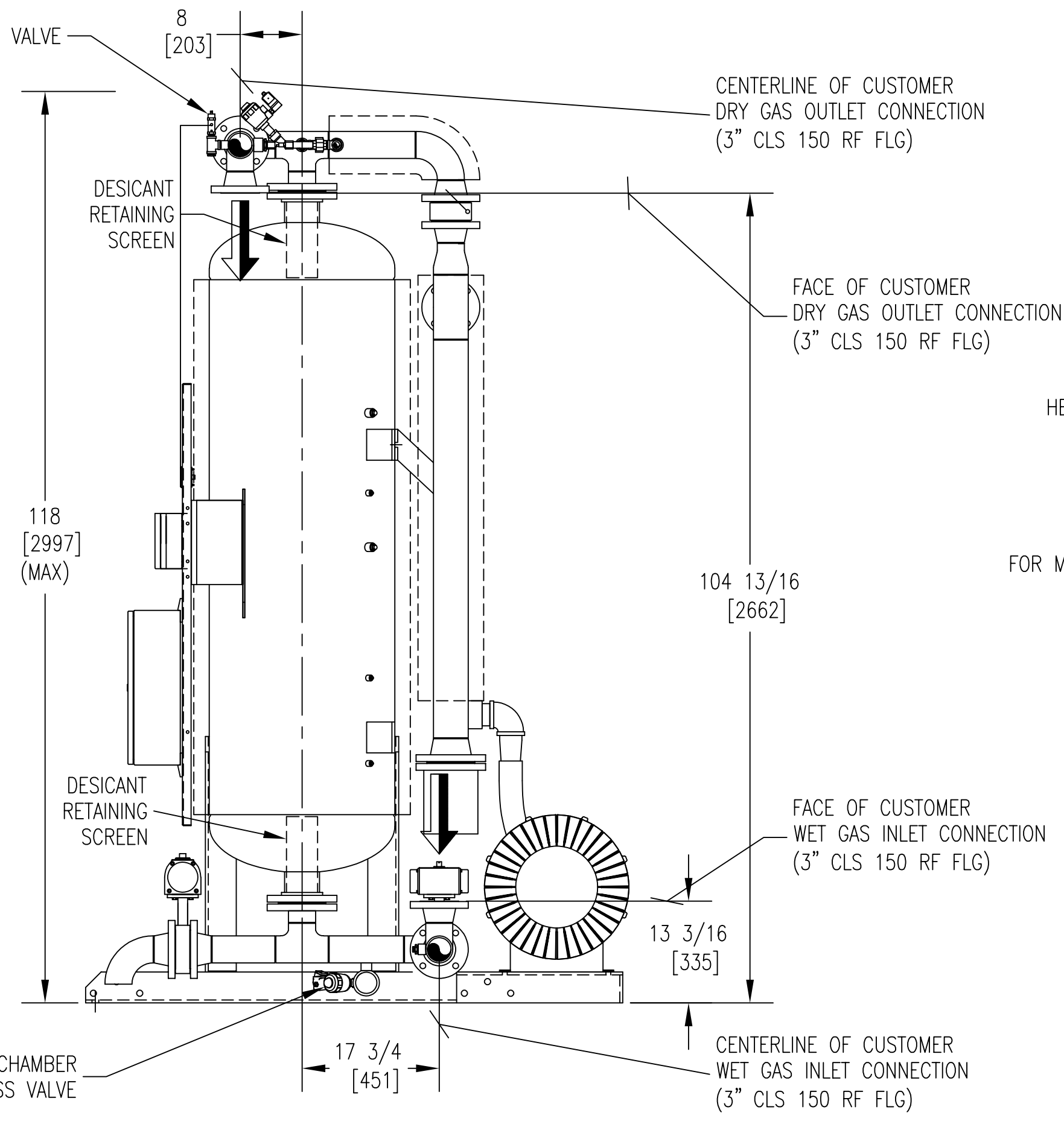

SIDE VIEW (RIGHT CHAMBER REMOVED FOR CLARITY)

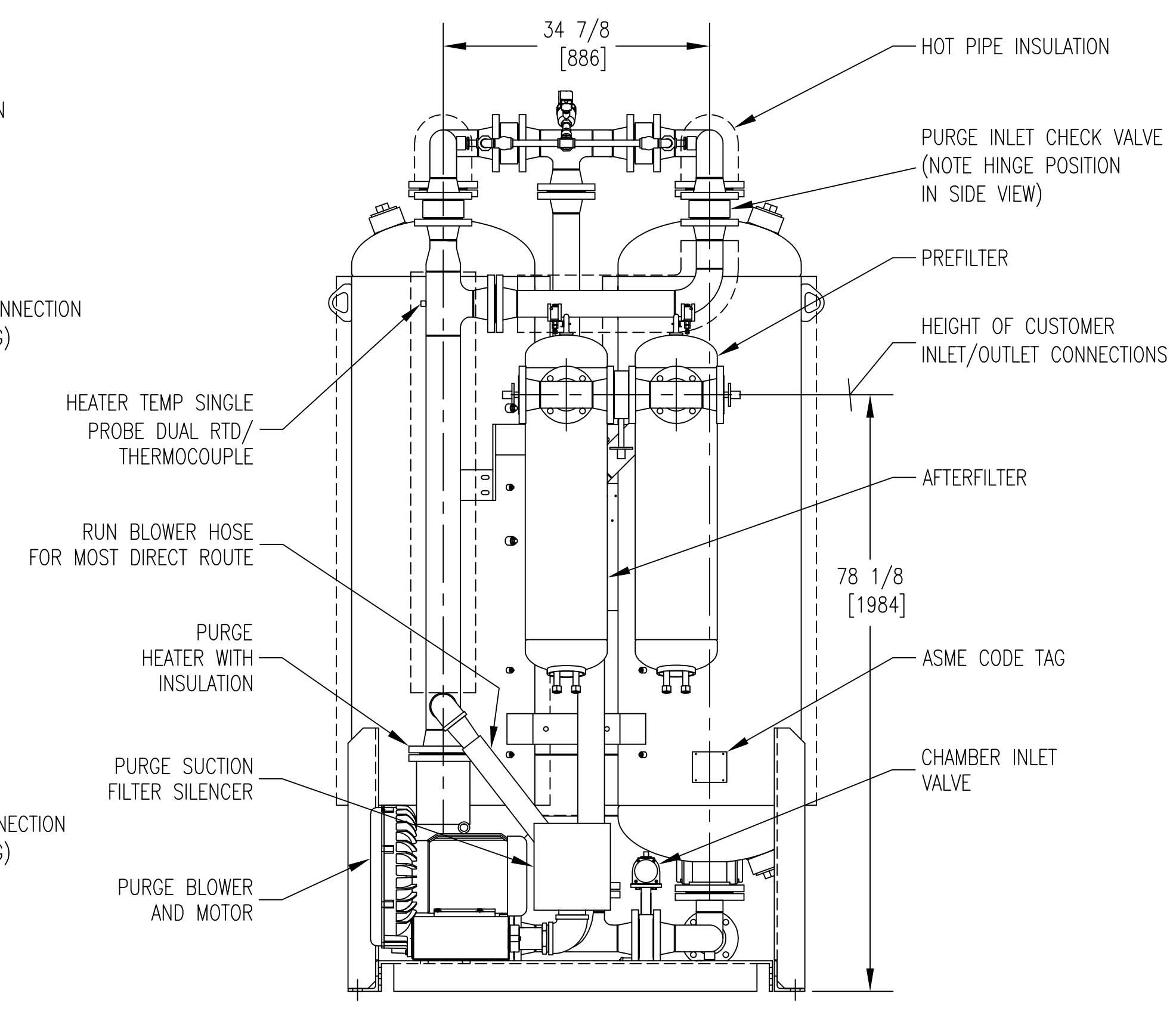

REAR VIEW (F01/F02 PKG OPTIONAL)

- NOTES:
- THIS DRAWING, TOGETHER WITH THE P&ID AND SPECIFICATION SHEET, PROVIDES OPERATING CONDITIONS, SPECIFICATIONS, INSTALLATION, MOUNTING AND CONNECTION REQUIREMENTS.
 - PRESSURE VESSELS ARE DESIGNED AND BUILT IN ACCORDANCE WITH THE CURRENT EDITION AND ADDENDA OF SECTION VIII, DIV. I, OF THE A.S.M.E. CODE FOR UNFIRED PRESSURE VESSELS.
 - ELECTRICAL CONSTRUCTION IS IN ACCORDANCE WITH THE NATIONAL ELECTRICAL CODE.
 - ANCHOR BOLTS ARE TO PROJECT A MINIMUM OF 2" ABOVE THE FOUNDATION. ANCHOR BOLTS SHOULD BE INSTALLED IN SLEEVES TO ALLOW SOME ADJUSTMENT AT TIME OF INSTALLATION.
 - FOR MAINTENANCE PURPOSES, RECOMMENDED CLEARANCE AROUND DRYER IS 4 FEET [1220 MM].
 - IF THE EQUIPMENT IS TO DRY (OR REACTIVATE WITH) A GAS OTHER THAN AIR, THE OUTLETS OF THE SAFETY VALVE, REACTIVATION GAS OUTLET LINE, BLOWDOWN VALVES, ETC. SHALL BE PIPED AWAY TO A SAFE LOCATION (BY PURCHASER). IN PIPING AWAY GAS, DO NOT PIPE UPWARD WITHOUT ADEQUATE ARRANGEMENTS TO PREVENT TRAPPING CONDENSATION.
 - WEIGHTS: SHIPPING WEIGHT 3,326 LBS. (APPROX.)
OPERATING WEIGHT 3,326 LBS. (APPROX.)
1,509 KGS
1,509 KGS
 - WHEN FILTER OPTION IS SUPPLIED, REMOVE FILTER AND FILTER PIPING FOR SHIPPING.

UNLESS OTHERWISE SPECIFIED:		NAME	DATE	UNAUTHORIZED USE, MANUFACTURE, OR REPRODUCTION IN WHOLE OR IN PART IS PROHIBITED. DRAWING DESIGN AND OTHER DISCLOSURES ARE PROPERTY OF:
DIMENSIONS ARE IN: INCHES/MM		DWN BY	SDM 01/17/05	 deltech-spx.com * DO NOT SCALE. USE DIMENSIONS ONLY *
SURFACE FINISH: N/A ✓		ENG BY	DEH 01/17/05	
TOL. MM INCHES		CHK BY	SDM 01/17/05	
X. - -		APP BY	DEH 01/17/05	
.XX - -		REL BY	SDM 01/17/05	
.XXX - -		MAT NO.	----	GENERAL ARRANGEMENT ZP 1300
FRACT: ±1/2 ANG: ±2°		SIZE DWG. NO.	D 0017108-1300	
SCALE: 1/16 WT: N/A		REV. SHEET	D 1/1	