

TOP VIEW
(4' OPTION FILTER PACKAGE)

TOP VIEW
(2' & 3' OPTION FILTER PACKAGE)

TOP VIEW
(1' OPTION FILTER PACKAGE)

- NOTES:
- THIS DRAWING, TOGETHER WITH P&ID AND SPECIFICATION SHEET, PROVIDES OPERATING CONDITIONS, SPECIFICATIONS, INSTALLATION, MOUNTING AND CONNECTION REQUIREMENTS.
 - PRESSURE VESSELS ARE DESIGNED AND BUILT IN ACCORDANCE WITH THE CURRENT CODE AND ADDENDA OF SECTION VIII, DIV. 1, OF THE A.S.M.E. CODE FOR UNFIRED PRESSURE VESSELS.
 - ELECTRICAL CONSTRUCTION IS IN ACCORDANCE WITH THE NATIONAL ELECTRICAL CODE.
 - ANCHOR BOLTS ARE TO PROJECT A MINIMUM OF 2" ABOVE THE FOUNDATION. ANCHOR BOLTS SHOULD BE INSTALLED IN SLEEVES TO ALLOW SOME ADJUSTMENT AT TIME OF INSTALLATION.

- FOR MAINTENANCE PURPOSES, RECOMMENDED CLEARANCE AROUND DRYER IS 4 FEET [1220 MM].
- IF THE EQUIPMENT IS TO DRY (OR REACTIVATE WITH) A GAS OTHER THAN AIR, THE OUTLETS OF THE SAFETY VALVE, REACTIVATION GAS OUTLET LINE, BLOWDOWN VALVES, ETC. TO BE PIPED AWAY TO A SAFE LOCATION (BY PURCHASER). IN PIPING AWAY GAS, DO NOT PIPE UPWARD WITHOUT ADEQUATE ARRANGEMENTS TO PREVENT TRAPPING CONDENSATION.
- CUSTOMER SHOULD REQUEST A COPY OF QMS-013 IF PLANNING ON STORING UNIT LONG TERM BEFORE PLACING INTO SERVICE.
- WEIGHTS: SHIPPING WEIGHT 1010 LBS. (APPROX.)
458 KGS
OPERATING WEIGHT 1010 LBS. (APPROX.)
458 KGS

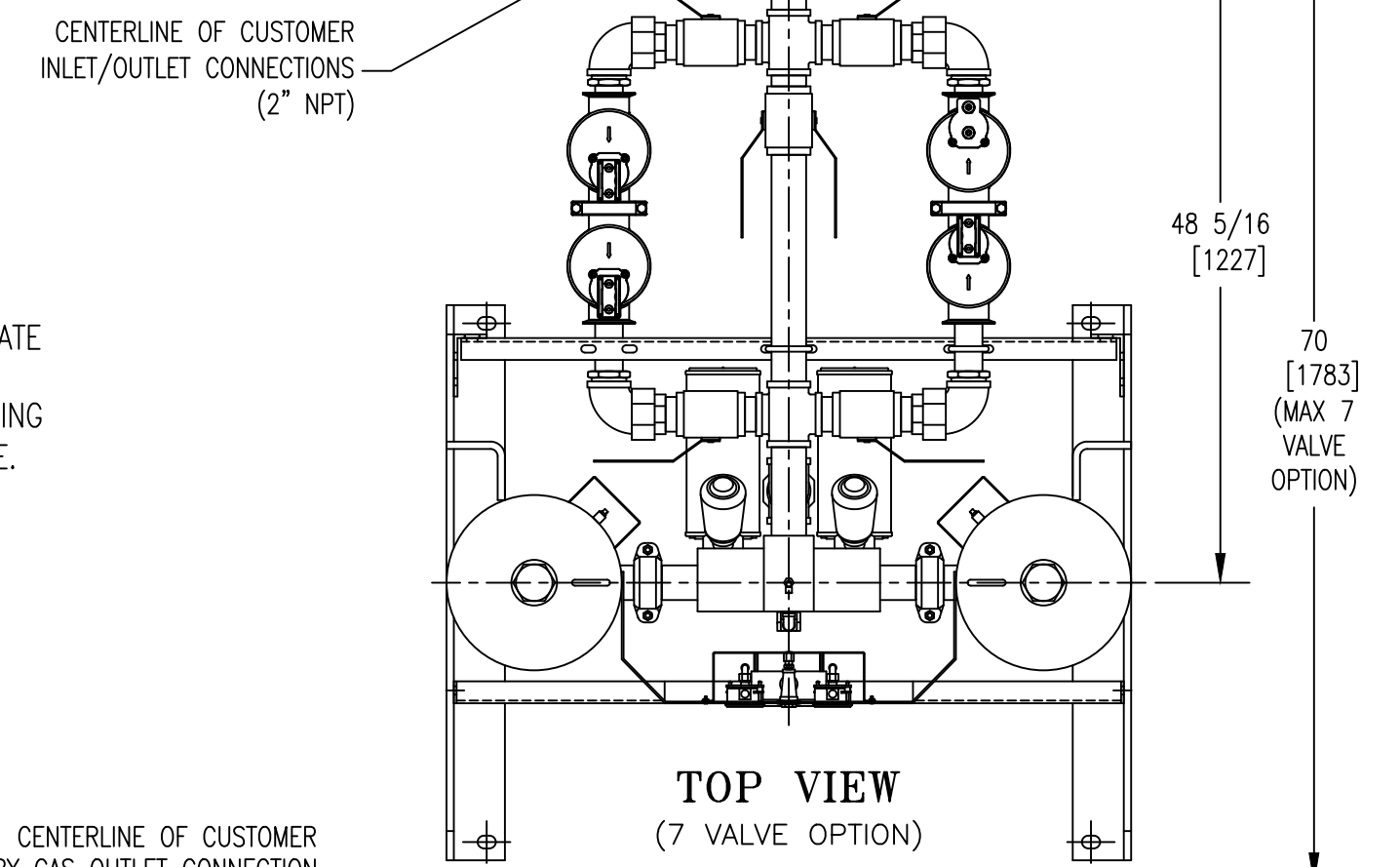

TOP VIEW
(7 VALVE OPTION)

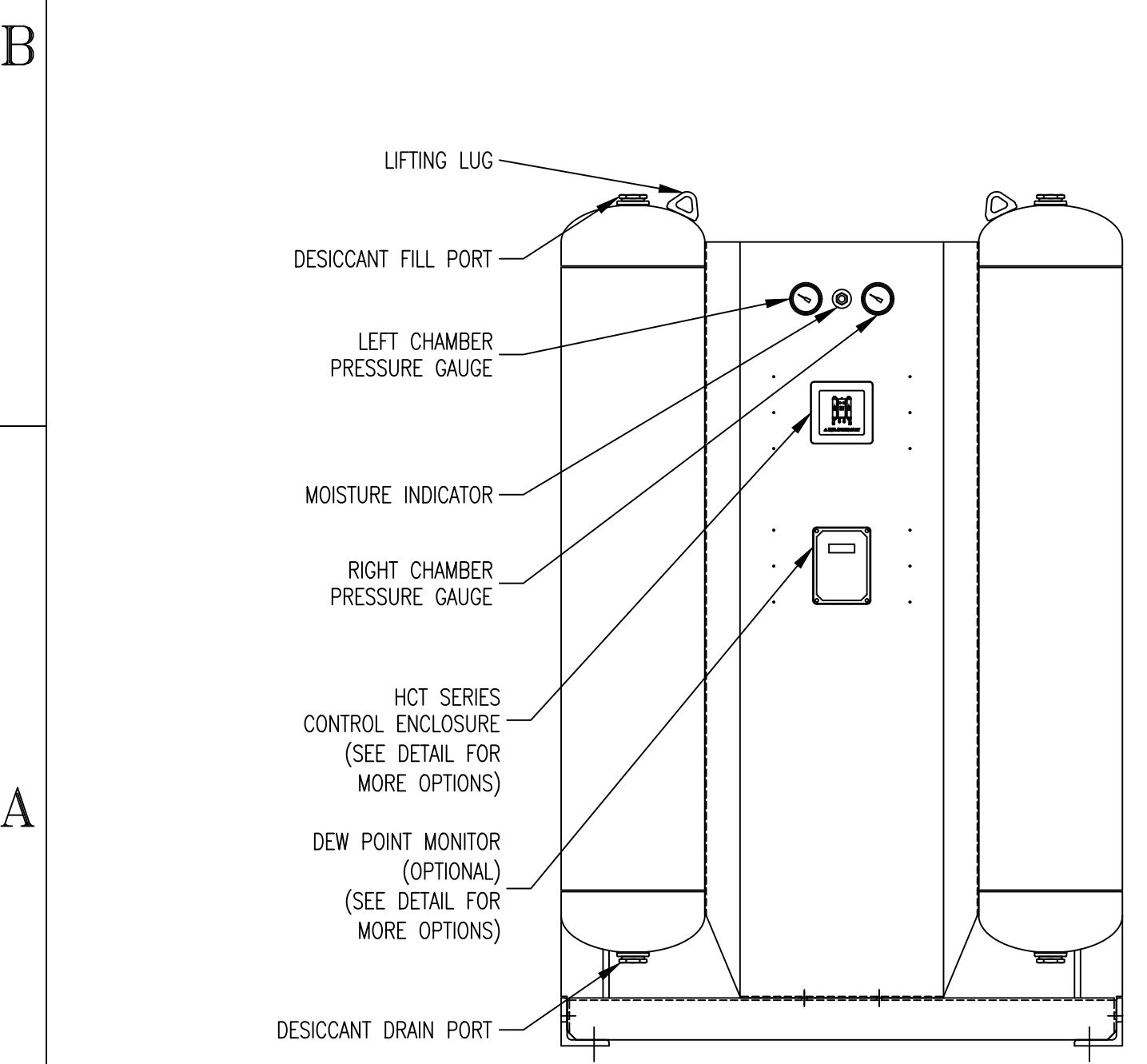

FRONT VIEW

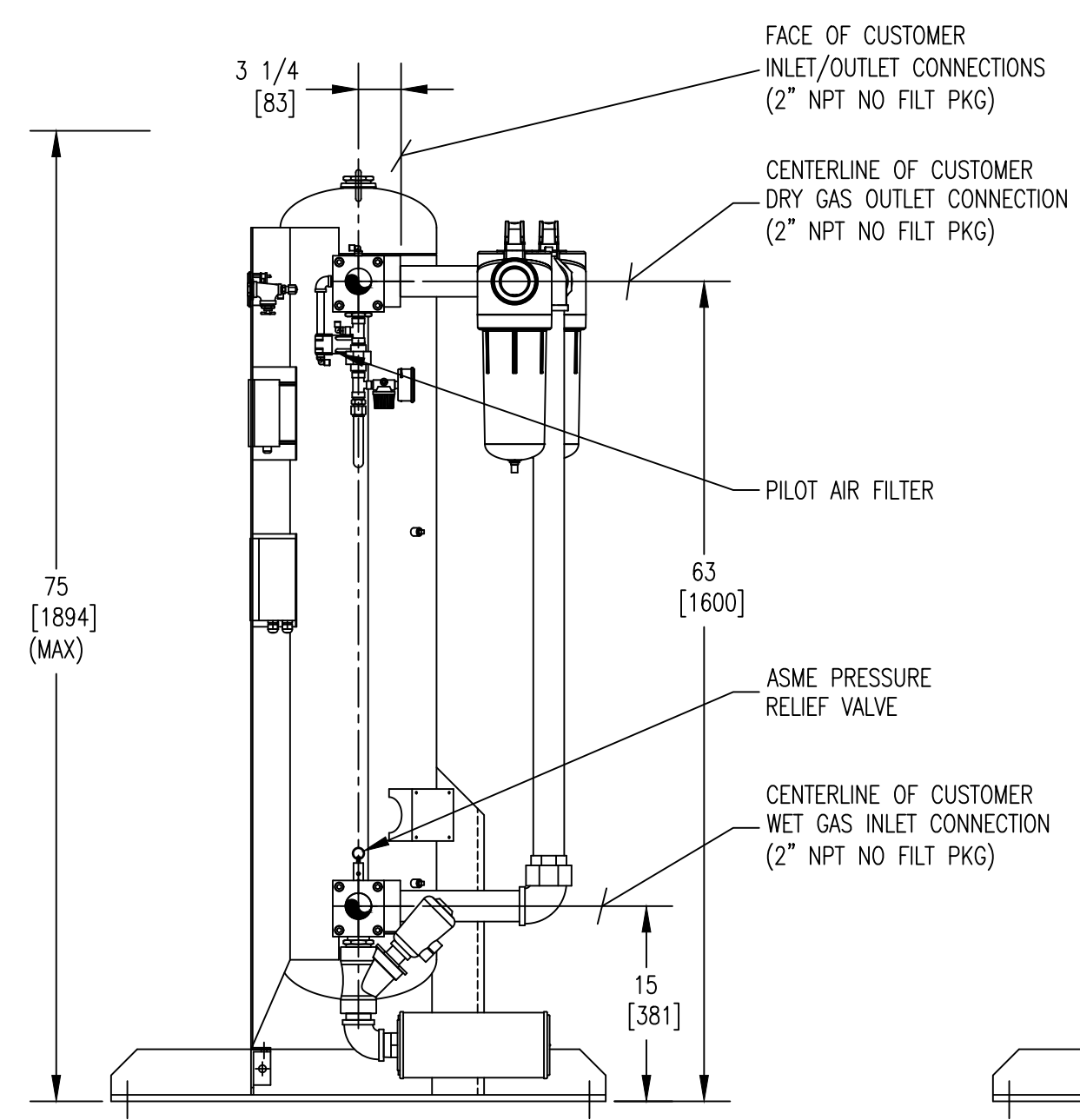

SIDE VIEW
(RIGHT CHAMBER REMOVED FOR CLARITY)

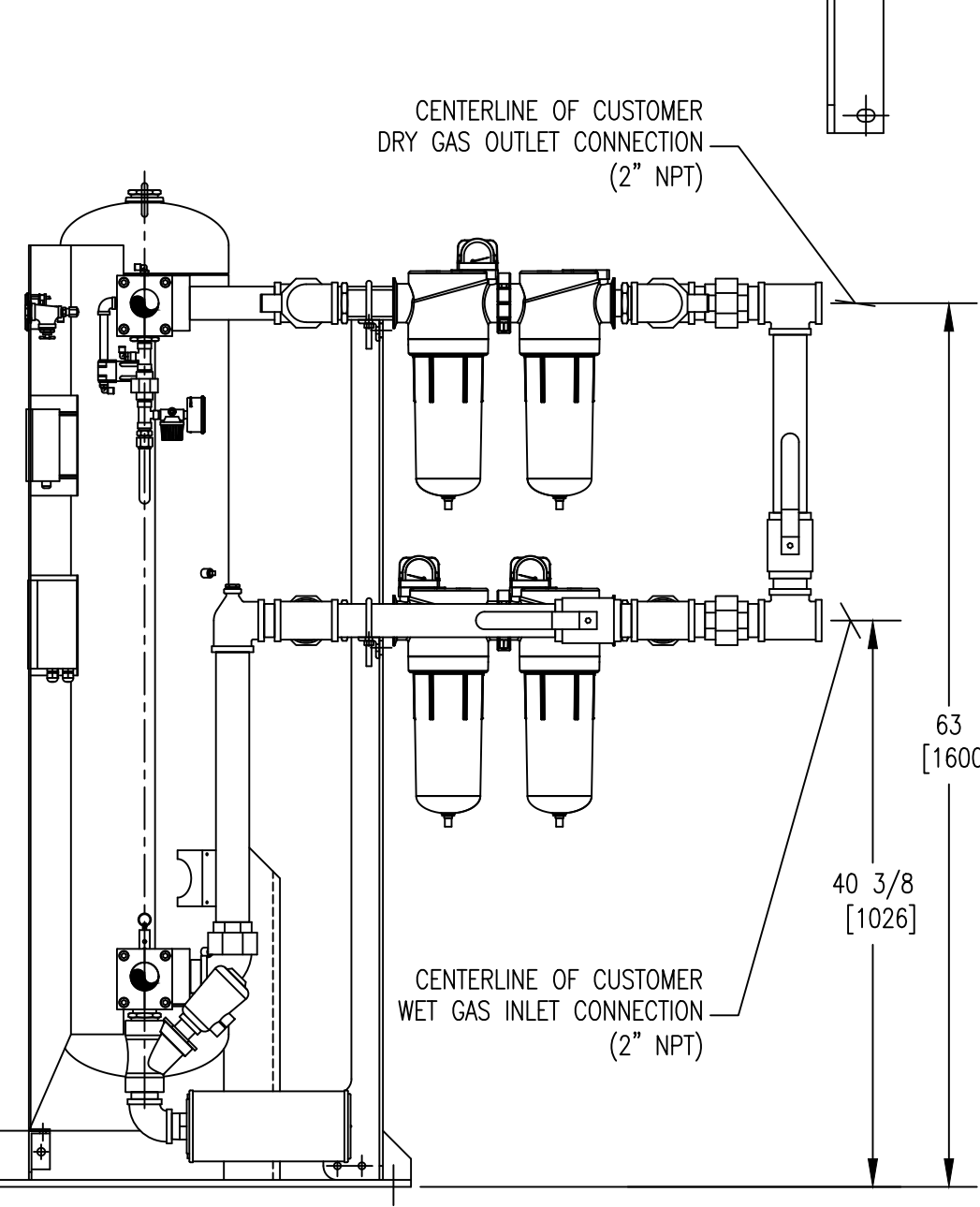

SIDE VIEW
(RIGHT CHAMBER REMOVED FOR CLARITY)
(7 VALVE OPTION)

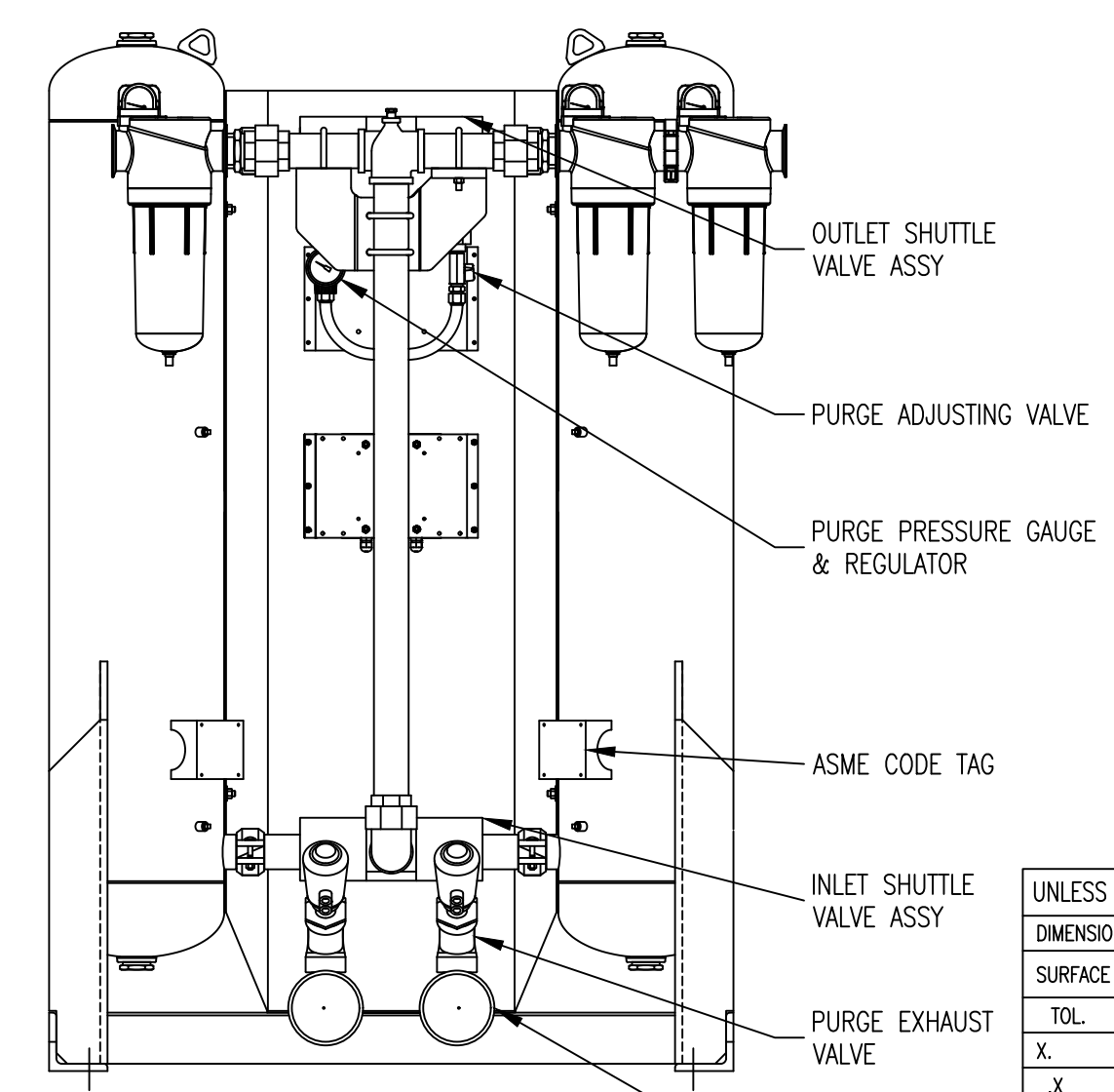

REAR VIEW
(2' & 3' OPTION FILTER PACKAGE)

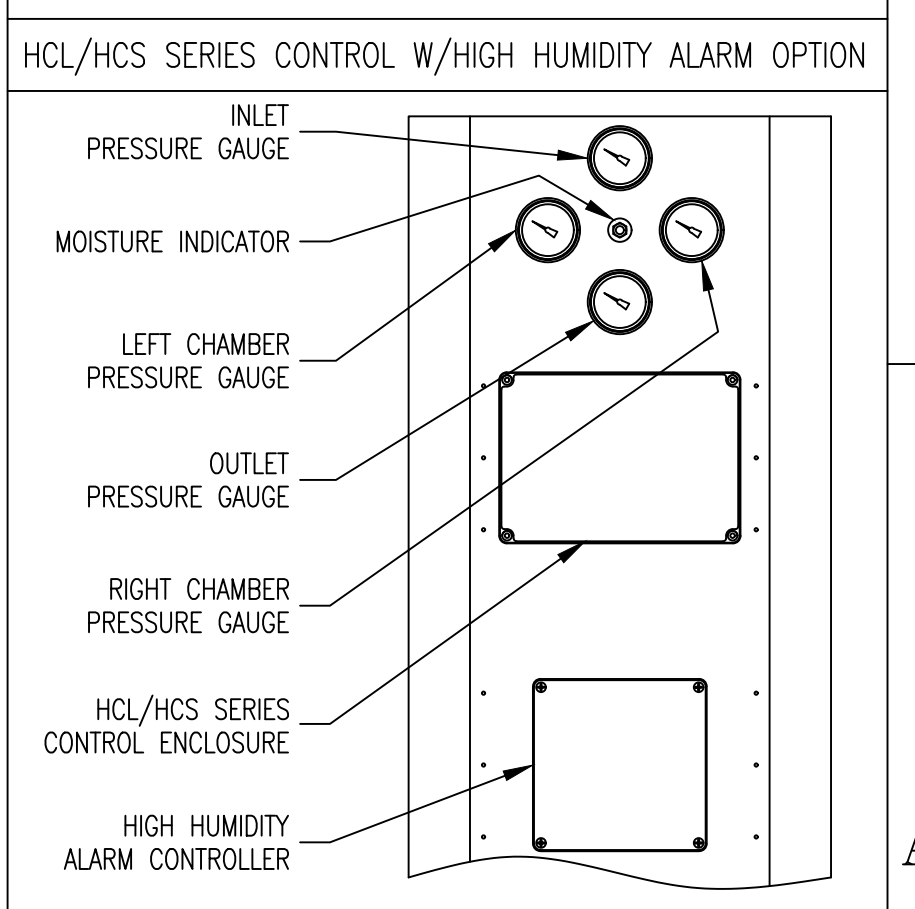
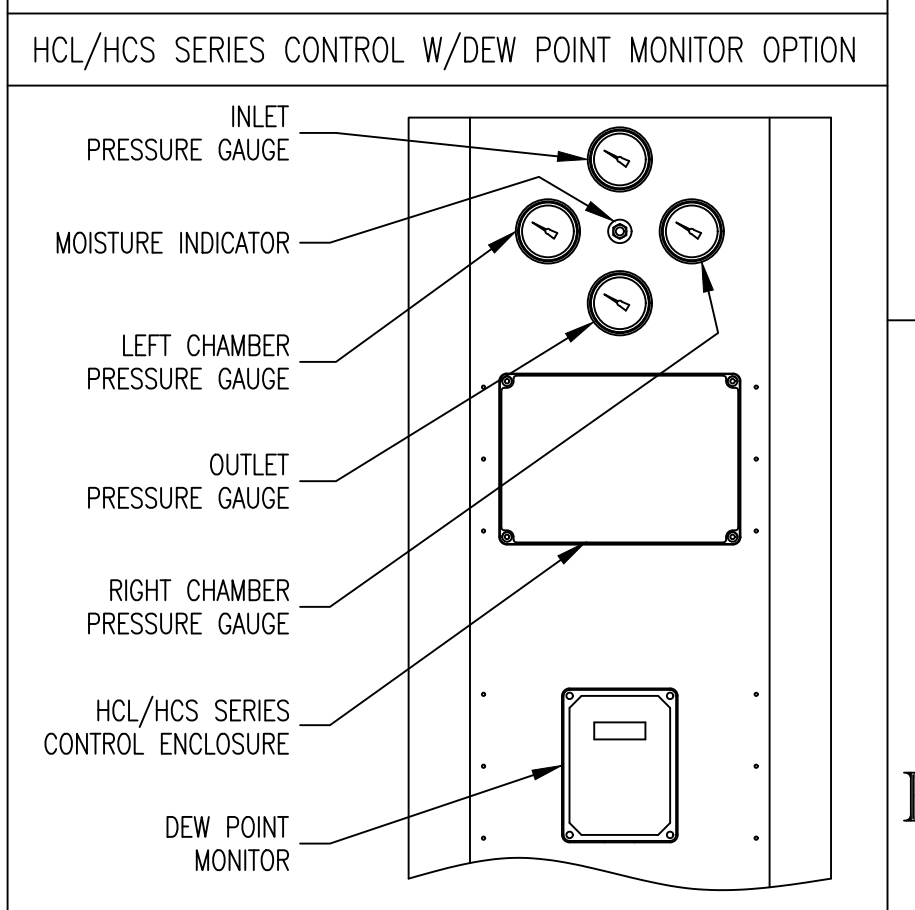
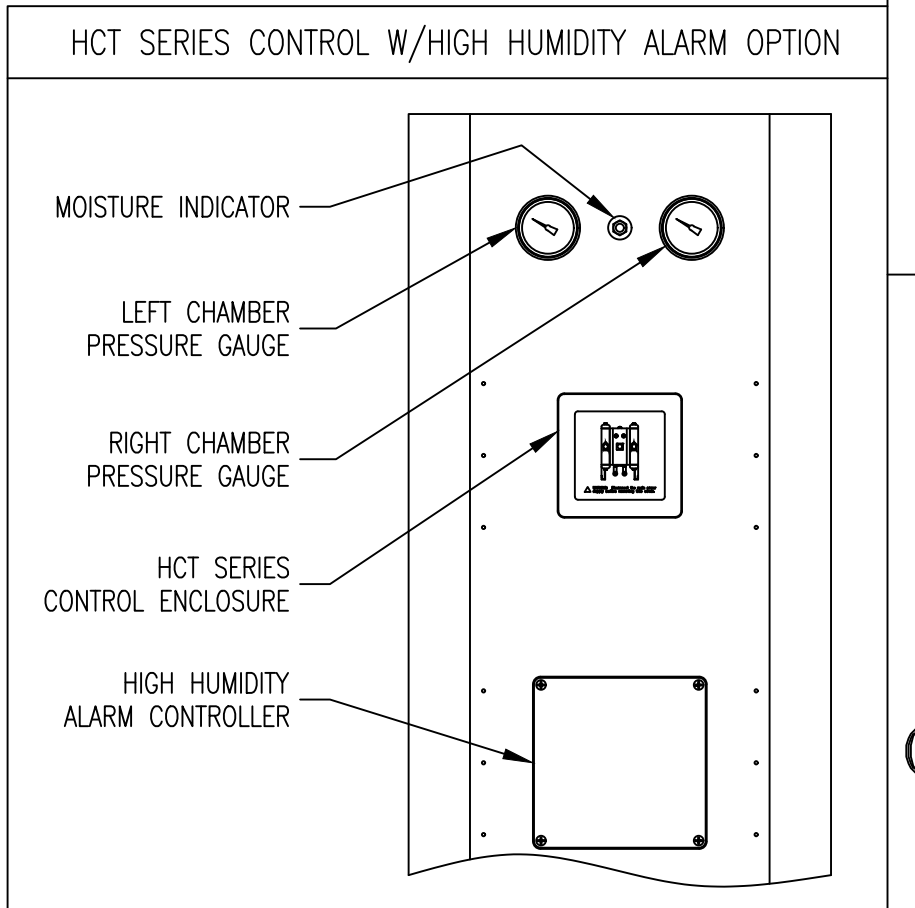

UNLESS OTHERWISE SPECIFIED:		NAME	DATE	UNAUTHORIZED USE, MANUFACTURE, OR REPRODUCTION IN WHOLE OR IN PART IS PROHIBITED. DRAWING DESIGN AND OTHER DISCLOSURES ARE PROPERTY OF:  AN SPX BRAND * DO NOT SCALE. USE DIMENSIONS ONLY *
DIMENSIONS ARE IN: INCHES/MM		DWN BY	SDM 08/01/11	
SURFACE FINISH: N/A ✓		ENG BY	DEB 08/01/11	
TOL. MM INCHES		CHK BY	DBR 08/01/11	
X. .XXX		APP BY	MPS 08/01/11	
FRACT: ±1/2 ANG: ±2°		REL BY	SDM 08/01/11	
SCALE: 5/64 WT: N/A		CAT NO.		GENERAL ARRANGEMENT HCS/HCL/HCT 260
		ID NO.		