

ITEM	QTY.	STOCK #	Description
1	1	AG3998887	HEAT EXCHANGER, AIR-AIR
2	1	AG3998886	HEAT EXCHANGER, AIR-REFRIG
3	1	AG3481564	DEMISTER PAD, 14" OD, 6" TH
4	1	AG3480088	GAUGE, SUCTION, PRESSURE
5	1	AG3480217	GAUGE, DISCHARGE PRESSURE
6	1	AG3480087	GAUGE, AIR INLET PRESSURE
7	1	AG3112001	TEMP GAUGE
8	2	AG3942303	VALVE, BALL-Y-STRAINER COMBO
9	2	AG3939988	CONDENSATE DRAIN
10	1	AG3952003	VALVE, EXPANSION
11	2	AG3935103	VALVE, BALL, REFRIGERATION
12	1	AG3234901	HOT GAS BYPASS
13	1	AG3235001	VALVE, HOT GAS BYPASS
14	2	AG3949950	FAN CYCLE CONTROL
15	1	AG3109201	LIQUID LINE FILTER
16	1	AG3940175	VALVE, BALL, REFRIGERATION, LIQUID LINE
17	1	AG3480825	MOISTURE INDICATOR
18	1	AG3935645	SS VIBRATION ABSORBER
19	1	AG3940189	SS VIBRATION ABSORBER
20	1	AG3942020	WELD COMP (COMPRESSOR)
21	1	AG3942011	FAN MOTOR
22	1	AG3942012	FAN BLADES
23	1	AG3942023	TANK-LIQUID REC
24	1	AG3942014	TANK-ACCUMULATOR
25	1	AG3976039	PRESSURE TRANSDUCER
26	1	AG3976040	PRESSURE TRANSDUCER KIT
27	1	AG3480520	CONTACTOR KIT
28	1	AG3998930	HEATER-CRANKCASE
29	1	AG3482532	ELECTRONIC UNIT CONTROLLER
30	1	AG3954650	PERFORMANCE ALERT
31	1	AG3236801	SUCTION VALVE
32	1	AG3482438	DISCHARGE VALVE
33	1	AG3948950	FUSE, CLASS CC
34	1	AG3254601	TRANSFORMER
35	1	AG3954651	DISCHARGE LINE THERMISTOR

UNLESS OTHERWISE SPECIFIED:
 DIMENSIONS ARE IN INCHES
 TOLERANCES:
 FRACTIONAL: ± 0.125
 ANGULAR: ± 0.5°
 TWO PLACE DECIMAL ± .03
 THREE PLACE DECIMAL ± .003

 THIRD ANGLE PROJECTION

MATERIAL

FINISH

DO NOT SCALE DRAWING

	NAME	DATE
DRAWN	BH	05/09/17
CHECKED	JJ	05/09/17
ENG APPR.		
MFG APPR.		
Q.A.		
COMMENTS:		

Aircel COMPRESSED AIR AND GAS PRODUCTS
 323 CRISP CIRCLE
 MARYVILLE TENNESSEE 37801
 PHONE: 865-681-7066
 FAX: 865-681-7069

TITLE: VF-2000, REFRIGERATED AIR DRYER, 2000 SCFM, 100 PSIG, 100F, SPARE PARTS

SIZE	DWG. NO.	REV
B	AG3024101	1

SCALE: 1:50 WEIGHT: SHEET 1 OF 2

PROPRIETARY AND CONFIDENTIAL
 THE INFORMATION CONTAINED IN THIS DRAWING IS THE SOLE PROPERTY OF AIRCEL LLC. ANY REPRODUCTION IN PART OR AS A WHOLE WITHOUT THE WRITTEN PERMISSION OF AIRCEL LLC IS PROHIBITED.

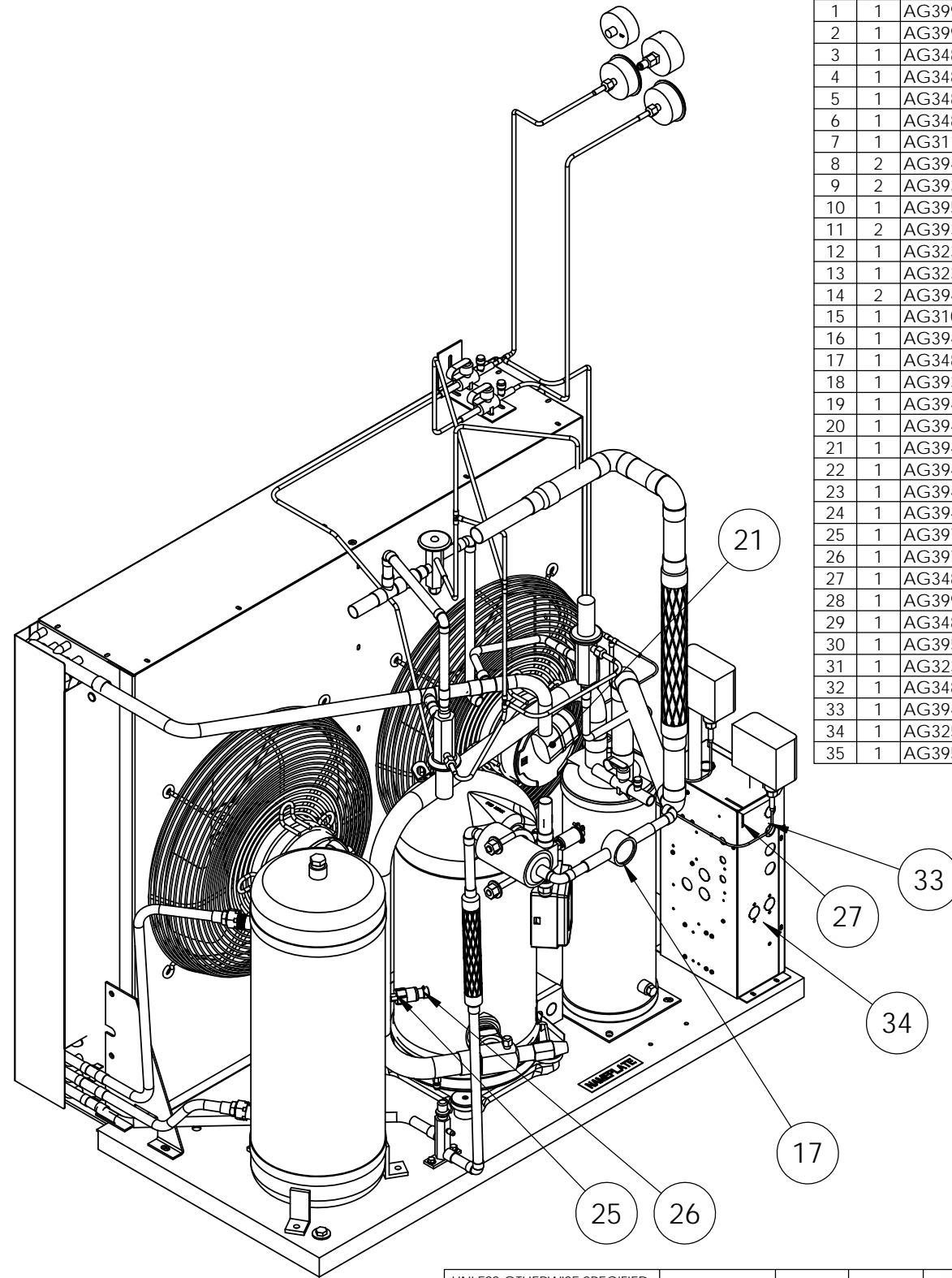
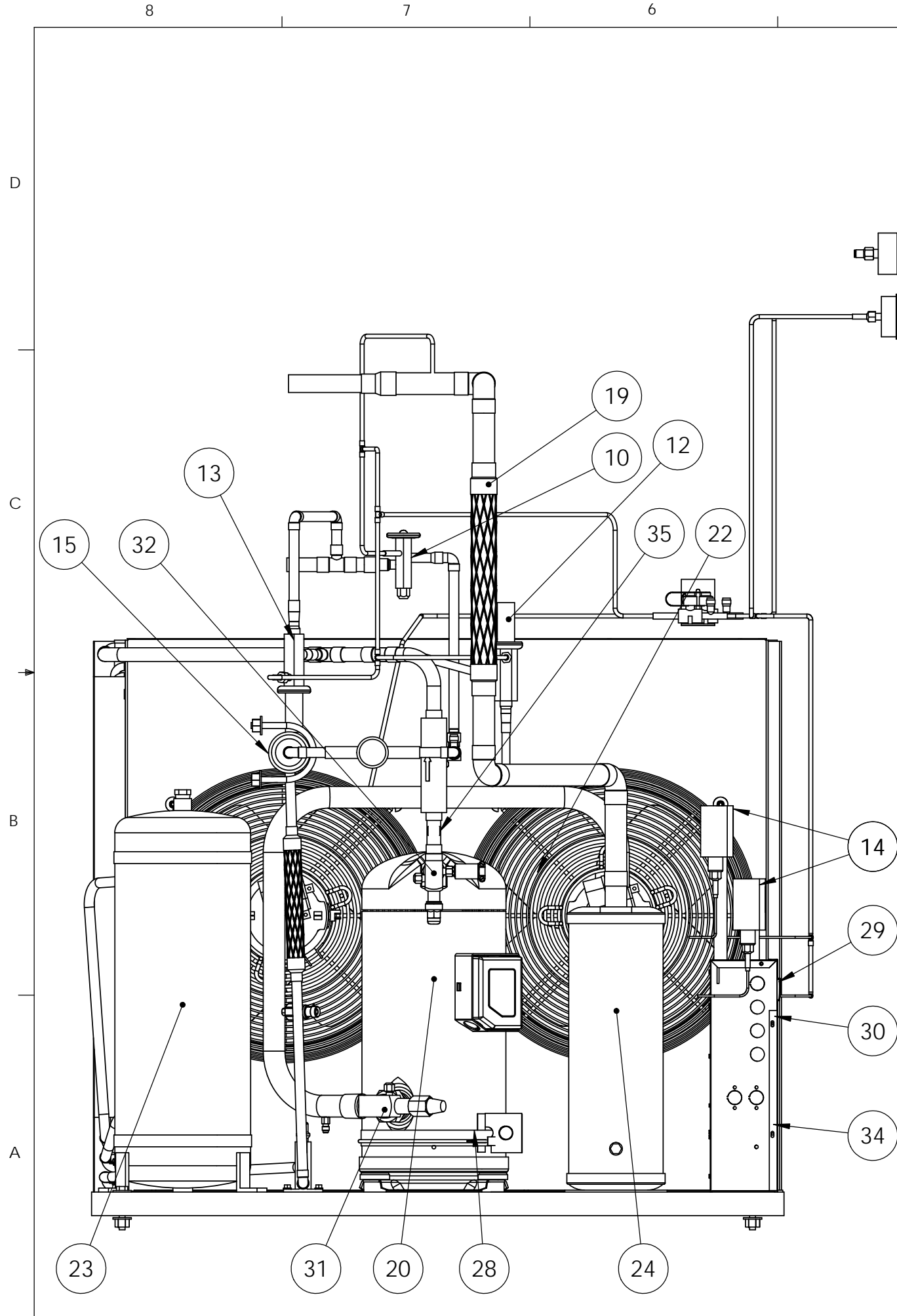

ITEM	QTY.	STOCK #	Description
1	1	AG3998887	HEAT EXCHANGER, AIR-AIR
2	1	AG3998886	HEAT EXCHANGER, AIR-REFRIG
3	1	AG3481564	DEMISTER PAD, 14" OD, 6" TH
4	1	AG3480088	GAUGE, SUCTION, PRESSURE
5	1	AG3480217	GAUGE, DISCHARGE PRESSURE
6	1	AG3480087	GAUGE, AIR INLET PRESSURE
7	1	AG3112001	TEMP GAUGE
8	2	AG3942303	VALVE, BALL-Y-STRAINER COMBO
9	2	AG3939988	CONDENSATE DRAIN
10	1	AG3952003	VALVE, EXPANSION
11	2	AG3935103	VALVE, BALL, REFRIGERATION
12	1	AG3234901	HOT GAS BYPASS
13	1	AG3235001	VALVE, HOT GAS BYPASS
14	2	AG3949950	FAN CYCLE CONTROL
15	1	AG3109201	LIQUID LINE FILTER
16	1	AG3940175	VALVE, BALL, REFRIGERATION, LIQUID LINE
17	1	AG3480825	MOISTURE INDICATOR
18	1	AG3935645	SS VIBRATION ABSORBER
19	1	AG3940189	SS VIBRATION ABSORBER
20	1	AG3942020	WELD COMP (COMPRESSOR)
21	1	AG3942011	FAN MOTOR
22	1	AG3942012	FAN BLADES
23	1	AG3942023	TANK-LIQUID REC
24	1	AG3942014	TANK-ACCUMULATOR
25	1	AG3976039	PRESSURE TRANSDUCER
26	1	AG3976040	PRESSURE TRANSDUCER KIT
27	1	AG3480520	CONTACTOR KIT
28	1	AG3998930	HEATER-CRANKCASE
29	1	AG3482532	ELECTRONIC UNIT CONTROLLER
30	1	AG3954650	PERFORMANCE ALERT
31	1	AG3236801	SUCTION VALVE
32	1	AG3482438	DISCHARGE VALVE
33	1	AG3948950	FUSE, CLASS CC
34	1	AG3254601	TRANSFORMER
35	1	AG3954651	DISCHARGE LINE THERMISTOR

UNLESS OTHERWISE SPECIFIED:
 DIMENSIONS ARE IN INCHES
 TOLERANCES:
 FRACTIONAL: ± 0.125
 ANGULAR: ± 0.5°
 TWO PLACE DECIMAL ± .03
 THREE PLACE DECIMAL ± .003

THIRD ANGLE PROJECTION
 MATERIAL
 FINISH
 DO NOT SCALE DRAWING

	NAME	DATE
DRAWN	BH	05/09/17
CHECKED	JJ	05/09/17
ENG APPR.		
MFG APPR.		
Q.A.		
COMMENTS:		

Aircel COMPRESSED AIR AND GAS PRODUCTS
 323 CRISP CIRCLE
 MARYVILLE TENNESSEE 37801
 PHONE: 865-681-7066
 FAX: 865-681-7069

TITLE: VF-2000, REFRIGERATED AIR DRYER, 2000 SCFM, 100 PSIG, 100F, SPARE PARTS

SIZE	DWG. NO.	REV
B	AG3024101	1

SCALE: 1:50 WEIGHT: SHEET 2 OF 1

PROPRIETARY AND CONFIDENTIAL
 THE INFORMATION CONTAINED IN THIS DRAWING IS THE SOLE PROPERTY OF AIRCEL LLC. ANY REPRODUCTION IN PART OR AS A WHOLE WITHOUT THE WRITTEN PERMISSION OF AIRCEL LLC IS PROHIBITED.